

STATE OF NORTH CAROLINA  
DEPARTMENT OF TRANSPORTATION  
RALEIGH, N.C.

C204455

CONTRACT AND  
CONTRACT BONDS  
FOR CONTRACT NO. C204455

WBS 15BPR.130.3 STATE FUNDED

COUNTY OF CHATHAM, MOORE  
THIS IS THE STRUCTURE CONTRACT  
ROUTE NUMBER \_\_\_\_\_ LENGTH 0.517 MILES  
LOCATION BRIDGES #180007, #180477, #620049, AND #620072 OVER THE DEEP RIVER  
ON US-1 SOUTH, SR-1621, AND NC-22.

CONTRACTOR FREYSSINET INC  
ADDRESS 44880 FALCON PLACE SUITE 100  
STERLING, VA 20166

BIDS OPENED JUNE 18, 2024

CONTRACT EXECUTION 07/09/2024

STATE OF NORTH CAROLINA  
DEPARTMENT OF TRANSPORTATION  
RALEIGH, N.C.

PROPOSAL

DATE AND TIME OF BID OPENING: **Jun 18, 2024 AT 02:00 PM**

CONTRACT ID C204455  
WBS 15BPR.130.3

FEDERAL-AID NO. STATE FUNDED  
COUNTY CHATHAM, MOORE  
T.I.P NO.  
MILES 0.517  
ROUTE NO.  
LOCATION BRIDGES #180007, #180477, #620049, AND #620072 OVER THE DEEP RIVER ON US-1 SOUTH, SR-1621, AND NC-22.  
TYPE OF WORK BRIDGE PRESERVATION.

**NOTICE:**

ALL BIDDERS SHALL COMPLY WITH ALL APPLICABLE LAWS REGULATING THE PRACTICE OF GENERAL CONTRACTING AS CONTAINED IN CHAPTER 87 OF THE GENERAL STATUTES OF NORTH CAROLINA WHICH REQUIRES THE BIDDER TO BE LICENSED BY THE N.C. LICENSING BOARD FOR CONTRACTORS WHEN BIDDING ON ANY NON-FEDERAL AID PROJECT WHERE THE BID IS \$30,000 OR MORE, EXCEPT FOR CERTAIN SPECIALTY WORK AS DETERMINED BY THE LICENSING BOARD. BIDDERS SHALL ALSO COMPLY WITH ALL OTHER APPLICABLE LAWS REGULATING THE PRACTICES OF ELECTRICAL, PLUMBING, HEATING AND AIR CONDITIONING AND REFRIGERATION CONTRACTING AS CONTAINED IN CHAPTER 87 OF THE GENERAL STATUTES OF NORTH CAROLINA. NOTWITHSTANDING THESE LIMITATIONS ON BIDDING, THE BIDDER WHO IS AWARDED ANY FEDERAL - AID FUNDED PROJECT SHALL COMPLY WITH CHAPTER 87 OF THE GENERAL STATUTES OF NORTH CAROLINA FOR LICENSING REQUIREMENTS WITHIN 60 CALENDAR DAYS OF BID OPENING.

**BIDS WILL BE RECEIVED AS SHOWN BELOW:**

**THIS IS A STRUCTURE PROPOSAL**

**5% BID BOND OR BID DEPOSIT REQUIRED**

---

**PROPOSAL FOR THE CONSTRUCTION OF  
CONTRACT No. C204455 IN CHATHAM AND MOORE COUNTIES, NORTH CAROLINA  
DEPARTMENT OF TRANSPORTATION,  
RALEIGH, NORTH CAROLINA**

The Bidder has carefully examined the location of the proposed work to be known as Contract No. **C204455** has carefully examined the plans and specifications, which are acknowledged to be part of the proposal, the special provisions, the proposal, the form of contract, and the forms of contract payment bond and contract performance bond; and thoroughly understands the stipulations, requirements and provisions. The undersigned bidder agrees to bound upon his execution of the bid and subsequent award to him by the Board of Transportation in accordance with this proposal to provide the necessary contract payment bond and contract performance bond within fourteen days after the written notice of award is received by him. The undersigned Bidder further agrees to provide all necessary machinery, tools, labor, and other means of construction; and to do all the work and to furnish all materials, except as otherwise noted, necessary to perform and complete the said contract in accordance with the *2024 Standard Specifications for Roads and Structures* by the dates(s) specified in the Project Special Provisions and in accordance with the requirements of the Engineer, and at the unit or lump sum prices, as the case may be, for the various items given on the sheets contained herein.

The Bidder shall provide and furnish all the materials, machinery, implements, appliances and tools, and perform the work and required labor to construct and complete Contract No. **C204455** in **Chatham and Moore Counties**, for the unit or lump sum prices, as the case may be, bid by the Bidder in his bid and according to the proposal, plans, and specifications prepared by said Department, which proposal, plans, and specifications show the details covering this project, and hereby become a part of this contract.

The published volume entitled *North Carolina Department of Transportation, Raleigh, Standard Specifications for Roads and Structures, January 2024* with all amendments and supplements thereto, is by reference incorporated into and made a part of this contract; that, except as herein modified, all the construction and work included in this contract is to be done in accordance with the specifications contained in said volume, and amendments and supplements thereto, under the direction of the Engineer.

If the proposal is accepted and the award is made, the contract is valid only when signed either by the Contract Officer or such other person as may be designated by the Secretary to sign for the Department of Transportation. The conditions and provisions herein cannot be changed except over the signature of the said Contract Officer.

The quantities shown in the itemized proposal for the project are considered to be approximate only and are given as the basis for comparison of bids. The Department of Transportation may increase or decrease the quantity of any item or portion of the work as may be deemed necessary or expedient.

An increase or decrease in the quantity of an item will not be regarded as sufficient ground for an increase or decrease in the unit prices, nor in the time allowed for the completion of the work, except as provided for the contract.

Accompanying this bid is a bid bond secured by a corporate surety, or certified check payable to the order of the Department of Transportation, for five percent of the total bid price, which deposit is to be forfeited as liquidated damages in case this bid is accepted and the Bidder shall fail to provide the required payment and performance bonds with the Department of Transportation, under the condition of this proposal, within 14 calendar days after the written notice of award is received by him, as provided in the *Standard Specifications*; otherwise said deposit will be returned to the Bidder.



*State Contract Officer*

DocuSigned by:

*Ronald E. Davenport, Jr.* 05/15/2024

52C46046381F443...

**TABLE OF CONTENTS**

**COVER SHEET  
PROPOSAL SHEET**

**PROJECT SPECIAL PROVISIONS**

CONTRACT TIME AND LIQUIDATED DAMAGES: ..... G-1  
 INTERMEDIATE CONTRACT TIME NUMBER 1 AND LIQUIDATED DAMAGES: ..... G-1  
 MAJOR CONTRACT ITEMS: ..... G-2  
 SPECIALTY ITEMS: ..... G-3  
 FUEL PRICE ADJUSTMENT: ..... G-3  
 SCHEDULE OF ESTIMATED COMPLETION PROGRESS: ..... G-5  
 MINORITY BUSINESS ENTERPRISE AND WOMEN BUSINESS ENTERPRISE: ..... G-5  
 RESTRICTIONS ON ITS EQUIPMENT AND SERVICES: ..... G-21  
 USE OF UNMANNED AIRCRAFT SYSTEM (UAS): ..... G-21  
 EQUIPMENT IDLING GUIDELINES: ..... G-21  
 MAINTENANCE OF THE PROJECT: ..... G-22  
 TWELVE MONTH GUARANTEE: ..... G-23  
 OUTSOURCING OUTSIDE THE USA: ..... G-23  
 NOTE TO CONTRACTOR: ..... G-24

ROADWAY .....R-1

**STANDARD SPECIAL PROVISIONS**

AVAILABILITY OF FUNDS – TERMINATION OF CONTRACTS .....SSP-1  
 NCDOT GENERAL SEED SPECIFICATION FOR SEED QUALITY .....SSP-2  
 ERRATA .....SSP-5  
 PLANT AND PEST QUARANTINES .....SSP-6  
 MINIMUM WAGES .....SSP-7  
 TITLE VI AND NONDISCRIMINATION: .....SSP-8  
 ON-THE-JOB TRAINING .....SSP-17

**UNIT PROJECT SPECIAL PROVISIONS**

EROSION CONTROL ..... EC-1  
 STRUCTURE/BRIDGE PRESERVATION ..... BP-1

**PROPOSAL ITEM SHEET**

ITEM SHEET(S)

**PROJECT SPECIAL PROVISIONS****GENERAL****CONTRACT TIME AND LIQUIDATED DAMAGES:**

(7-1-95) (Rev. 12-18-07)

108

SP1 G10 A

The date of availability for this contract is **July 29, 2024**.

The completion date for this contract is **November 15, 2025**.

Except where otherwise provided by the contract, observation periods required by the contract will not be a part of the work to be completed by the completion date and/or intermediate contract times stated in the contract. The acceptable completion of the observation periods that extend beyond the final completion date shall be a part of the work covered by the performance and payment bonds.

The liquidated damages for this contract are **One Thousand Five Hundred Dollars (\$ 1,500.00)** per calendar day.

**INTERMEDIATE CONTRACT TIME NUMBER 1 AND LIQUIDATED DAMAGES:**

(2-20-07)

108

SP1 G14 A

The Contractor shall complete the required work of installing, maintaining, and removing the traffic control devices for lane closures and restoring traffic to the existing traffic pattern. The Contractor shall not close or narrow a lane of traffic on **US 1 (NB) or US 1 (SB)** during the following time restrictions:

**DAY AND TIME RESTRICTIONS****For Drift Removal Operations**

**Monday thru Sunday, from 3:00 P.M. to 9:00 A.M. (the following morning)**

**For Any Other Operation**

**Monday thru Sunday, from 6:00 A.M. to 7:00 P.M.**

In addition, the Contractor shall not close or narrow a lane of traffic on **US 1 (NB) or US 1 (SB)**, detain and/or alter the traffic flow on or during holidays, holiday weekends, special events, or any other time when traffic is unusually heavy, including the following schedules:

**HOLIDAY AND HOLIDAY WEEKEND LANE CLOSURE RESTRICTIONS**

1. For **unexpected occurrence** that creates unusually high traffic volumes, as directed by the Engineer.
2. For **New Year's Day**, between the hours of **6:00 A.M.** December 30<sup>th</sup> and **7:00 P.M.** January 2<sup>nd</sup>. If New Year's Day is on a Friday, Saturday, Sunday or Monday, then until **7:00 P.M.** the following Tuesday.

3. For **Easter**, between the hours of **6:00 A.M.** Thursday and **7:00 P.M.** Monday.
4. For **Memorial Day**, between the hours of **6:00 A.M.** Friday and **7:00 P.M.** Tuesday.
5. For **Independence Day**, between the hours of **6:00 A.M.** the day before Independence Day and **7:00 P.M.** the day after Independence Day.

If **Independence Day** is on a Friday, Saturday, Sunday or Monday, then between the hours of **6:00 A.M.** the Thursday before Independence Day and **7:00 P.M.** the Tuesday after Independence Day.

6. For **Labor Day**, between the hours of **6:00 A.M.** Friday and **7:00 P.M.** Tuesday.
7. For **Thanksgiving**, between the hours of **6:00 A.M.** Tuesday and **7:00 P.M.** Monday.
8. For **Christmas**, between the hours of **6:00 A.M.** the Friday before the week of Christmas Day and **7:00 P.M.** the following Tuesday after the week of Christmas Day.

Holidays and holiday weekends shall include New Year's, Easter, Memorial Day, Independence Day, Labor Day, Thanksgiving, and Christmas. The Contractor shall schedule his work so that lane closures will not be required during these periods, unless otherwise directed by the Engineer.

The time of availability for this intermediate contract work shall be the time the Contractor begins to install all traffic control devices for lane closures according to the time restrictions listed herein.

The completion time for this intermediate contract work shall be the time the Contractor is required to complete the removal of all traffic control devices for lane closures according to the time restrictions stated above and place traffic in the existing traffic pattern.

The liquidated damages for this intermediate contract time are **Five Hundred Dollars (\$ 500.00)** per fifteen (**15**) minute time period.

**MAJOR CONTRACT ITEMS:**

(2-19-02)(Rev. 1-16-24)

104

SP1 G28

The following listed items are the major contract items for this contract (see Article 104-5 of the *Standard Specifications*):

<b>Line #</b>	<b>Description</b>
41	Placing and Finishing of Latex Modified Concrete Overlay-Very Early Strength
42	Placing and Finishing Polymer Concrete Overlay
48	Polyester Polymer Concrete Materials

OR

<b>Line #</b>	<b>Description</b>
41	Placing and Finishing of Latex Modified Concrete Overlay-Very Early Strength
42	Placing and Finishing Polymer Concrete Overlay
49	Epoxy Polymer Concrete Materials

**SPECIALTY ITEMS:**

(7-1-95)(Rev. 1-16-24)

108-6

SP1 G37

Items listed below will be the specialty items for this contract (see Article 108-6 of the *Standard Specifications*).

<b>Line #</b>	<b>Description</b>
17-18	Long-Life Pavement Markings
19	Permanent Pavement Markers
22, 28-30	Bridge Painting
39, 42, 48	Polymer Concrete Overlay

OR

<b>Line #</b>	<b>Description</b>
17-18	Long-Life Pavement Markings
19	Permanent Pavement Markers
22, 28-30	Bridge Painting
39, 42, 49	Polymer Concrete Overlay (Alternate)

**FUEL PRICE ADJUSTMENT:**

(11-15-05)(Rev. 1-16-24)

109-8

SP1 G43

**Page 1-82, Article 109-8, FUEL PRICE ADJUSTMENTS**, add the following:

The base index price for DIESEL #2 FUEL is \$ **2.6456** per gallon. Where any of the following are included as pay items in the contract, they will be eligible for fuel price adjustment.

The pay items and the fuel factor used in calculating adjustments to be made will be as follows:

<b>Description</b>	<b>Units</b>	<b>Fuel Usage Factor Diesel</b>
Unclassified Excavation	Gal/CY	0.29
Borrow Excavation	Gal/CY	0.29
Class IV Subgrade Stabilization	Gal/Ton	0.55
Aggregate Base Course	Gal/Ton	0.55
Sub-Ballast	Gal/Ton	0.55
Erosion Control Stone	Gal/Ton	0.55
Rip Rap, Class _____	Gal/Ton	0.55
Asphalt Concrete Base Course, Type _____	Gal/Ton	0.90 or 2.90
Asphalt Concrete Intermediate Course, Type _____	Gal/Ton	0.90 or 2.90
Asphalt Concrete Surface Course, Type _____	Gal/Ton	0.90 or 2.90
Open-Graded Asphalt Friction Course	Gal/Ton	0.90 or 2.90
Permeable Asphalt Drainage Course, Type _____	Gal/Ton	0.90 or 2.90
Sand Asphalt Surface Course, Type _____	Gal/Ton	0.90 or 2.90
Ultra-thin Bonded Wearing Course	Gal/Ton	0.90 or 2.90
Aggregate for Cement Treated Base Course	Gal/Ton	0.55
Portland Cement for Cement Treated Base Course	Gal/Ton	0.55
> 11" Portland Cement Concrete Pavement	Gal/SY	0.327
Concrete Shoulders Adjacent to > 11" Pavement	Gal/SY	0.327
9" to 11" Portland Cement Concrete Pavement	Gal/SY	0.272
Concrete Shoulders Adjacent to 9" to 11" Pavement	Gal/SY	0.272
< 9" Portland Cement Concrete Pavement	Gal/SY	0.245
Concrete Shoulders Adjacent to < 9" Pavement	Gal/SY	0.245

For the asphalt items noted in the chart as eligible for fuel adjustments, the bidder may include the *Fuel Usage Factor Adjustment Form* with their bid submission if they elect to use the fuel usage factor. The *Fuel Usage Factor Adjustment Form* is found at the following link:

<https://connect.ncdot.gov/letting/LetCentral/Fuel%20Usage%20Factor%20Adjustment%20Form%20-%20Starting%20Nov%202022%20Lettings.pdf>

Select either 2.90 Gal/Ton fuel factor or 0.90 Gal/Ton fuel factor for each asphalt line item on the *Fuel Usage Factor Adjustment Form*. The selected fuel factor for each asphalt item will remain in effect for the duration of the contract.

Failure to complete the *Fuel Usage Factor Adjustment Form* will result in using 2.90 gallons per ton as the Fuel Usage Factor for Diesel for the asphalt items noted above. The contractor will not be permitted to change the Fuel Usage Factor after the bids are submitted.



**SCHEDULE OF ESTIMATED COMPLETION PROGRESS:**

(7-15-08)(Rev. 1-16-24)

108-2

SP1 G58

The Contractor's attention is directed to the Standard Special Provision entitled *Availability of Funds Termination of Contracts* included elsewhere in this proposal. The Department of Transportation's schedule of estimated completion progress for this project as required by that Standard Special Provision is as follows:

	<b><u>Fiscal Year</u></b>	<b><u>Progress (% of Dollar Value)</u></b>
2025	(7/01/24 - 6/30/25)	<b>84%</b> of Total Amount Bid
2026	(7/01/25 - 6/30/26)	<b>16%</b> of Total Amount Bid

The Contractor shall also furnish his own progress schedule in accordance with Article 108-2 of the *Standard Specifications*. Any acceleration of the progress as shown by the Contractor's progress schedule over the progress as shown above shall be subject to the approval of the Engineer.

**MINORITY BUSINESS ENTERPRISE AND WOMEN BUSINESS ENTERPRISE:**

(10-16-07)(Rev. 1-16-24)

102-15(J)

SP1 G66

**Description**

The purpose of this Special Provision is to carry out the North Carolina Department of Transportation's policy of ensuring nondiscrimination in the award and administration of contracts financed in whole or in part with State funds.

**Definitions**

*Additional MBE/WBE Subcontractors* - Any MBE/WBE submitted at the time of bid that will not be used to meet the Combined MBE /WBE Goal. No submittal of a Letter of Intent is required.

*Combined MBE/WBE Goal:* A portion of the total contract, expressed as a percentage that is to be performed by committed MBE/WBE subcontractors.

*Committed MBE/WBE Subcontractor* - Any MBE/WBE submitted at the time of bid that is being used to meet the Combined MBE /WBE goal by submission of a Letter of Intent. Or any MBE or WBE used as a replacement for a previously committed MBE or WBE firm.

*Contract Goal Requirement* - The approved participation at time of award, but not greater than the advertised Combined MBE/WBE contract goal.

*Goal Confirmation Letter* - Written documentation from the Department to the bidder confirming the Contractor's approved, committed participation along with a listing of the committed MBE and WBE firms.

*Manufacturer* - A firm that operates or maintains a factory or establishment that produces on the premises, the materials or supplies obtained by the Contractor.

*MBE Participation (Anticipated)* - A portion of the total contract, expressed as a percentage that is anticipated to be performed by committed MBE subcontractor(s).

*Minority Business Enterprise (MBE)* - A firm certified as a Disadvantaged Minority-Owned Business Enterprise through the North Carolina Unified Certification Program.

*Regular Dealer* - A firm that owns, operates, or maintains a store, warehouse, or other establishment in which the materials or supplies required for the performance of the contract are bought, kept in stock, and regularly sold to the public in the usual course of business. A regular dealer engages in, as its principal business and in its own name, the purchase and sale or lease of the products in question. A regular dealer in such bulk items as steel, cement, gravel, stone, and petroleum products need not keep such products in stock, if it owns and operates distribution equipment for the products. Brokers and packagers are not regarded as manufacturers or regular dealers within the meaning of this section.

*Replacement / Substitution* – A full or partial reduction in the amount of work subcontracted to a committed (or an approved substitute) MBE/WBE firm.

*North Carolina Unified Certification Program (NCUCP)* - A program that provides comprehensive services and information to applicants for MBE/WBE certification. The MBE/WBE program follows the same regulations as the federal Disadvantaged Business Enterprise (DBE) program in accordance with 49 CFR Part 26.

*United States Department of Transportation (USDOT)* - Federal agency responsible for issuing regulations (49 CFR Part 26) and official guidance for the DBE program.

*WBE Participation (Anticipated)* - A portion of the total contract, expressed as a percentage, that is anticipated to be performed by committed WBE subcontractor(s).

*Women Business Enterprise (WBE)* - A firm certified as a Disadvantaged Women-Owned Business Enterprise through the North Carolina Unified Certification Program.

### **Forms and Websites Referenced in this Provision**

*Payment Tracking System* - On-line system in which the Contractor enters the payments made to MBE and WBE subcontractors who have performed work on the project.  
<https://apps.dot.state.nc.us/Vendor/PaymentTracking/>

*DBE-IS Subcontractor Payment Information* - Form for reporting the payments made to all MBE/WBE firms working on the project. This form is for paper bid projects only.  
<https://connect.ncdot.gov/business/Turnpike/Documents/Form%20DBE-IS%20Subcontractor%20Payment%20Information.pdf>

*RF-1 MBE/WBE Replacement Request Form* - Form for replacing a committed MBE or WBE.  
<https://connect.ncdot.gov/projects/construction/Construction%20Forms/DBE%20MBE%20WBE%20Replacement%20Form%20and%20Instructions.pdf>

*SAF Subcontract Approval Form* - Form required for approval to sublet the contract.

<https://connect.ncdot.gov/projects/construction/Construction%20Forms/SAF%20Form%20-%20Subcontract%20Approval%20Form%20Revised%2004-19.xlsm>

*JC-1 Joint Check Notification Form* - Form and procedures for joint check notification. The form acts as a written joint check agreement among the parties providing full and prompt disclosure of the expected use of joint checks.

<http://connect.ncdot.gov/projects/construction/Construction%20Forms/Joint%20Check%20Notification%20Form.pdf>

*Letter of Intent* - Form signed by the Contractor and the MBE/WBE subcontractor, manufacturer or regular dealer that affirms that a portion of said contract is going to be performed by the signed MBE/WBE for the estimated amount (based on quantities and unit prices) listed at the time of bid.

<http://connect.ncdot.gov/letting/LetCentral/Letter%20of%20Intent%20to%20Perform%20as%20a%20Subcontractor.pdf>

*Listing of MBE and WBE Subcontractors Form* - Form for entering MBE/WBE subcontractors on a project that will meet the Combined MBE/WBE goal. This form is for paper bids only.

[http://connect.ncdot.gov/municipalities/Bid%20Proposals%20for%20LGA%20Content/09%20MBE-WBE%20Subcontractors%20\(State\).docx](http://connect.ncdot.gov/municipalities/Bid%20Proposals%20for%20LGA%20Content/09%20MBE-WBE%20Subcontractors%20(State).docx)

*Subcontractor Quote Comparison Sheet* - Spreadsheet for showing all subcontractor quotes in the work areas where MBEs and WBEs quoted on the project. This sheet is submitted with good faith effort packages.

<http://connect.ncdot.gov/business/SmallBusiness/Documents/DBE%20Subcontractor%20Quote%20Comparison%20Example.xls>

### **Combined MBE/WBE Goal**

The Combined MBE/WBE Goal for this project is **1.0 %**

The Combined Goal was established utilizing the following anticipated participation for Minority Business Enterprises and Women Business Enterprises:

(A) Minority Business Enterprises **0.0 %**

- (1) *If the anticipated MBE participation is more than zero*, the Contractor shall exercise all necessary and reasonable steps to ensure that MBEs participate in at least the percent of the contract as set forth above.
- (2) *If the anticipated MBE participation is zero*, the Contractor shall make an effort to recruit and use MBEs during the performance of the contract. Any MBE participation obtained shall be reported to the Department.

**(B) Women Business Enterprises 1.0 %**

- (1) *If the anticipated WBE participation is more than zero*, the Contractor shall exercise all necessary and reasonable steps to ensure that WBEs participate in at least the percent of the contract as set forth above.
- (2) *If the anticipated WBE participation is zero*, the Contractor shall make an effort to recruit and use WBEs during the performance of the contract. Any WBE participation obtained shall be reported to the Department.

The Bidder is required to submit only participation to meet the Combined MBE/WBE Goal. The Combined Goal may be met by submitting all MBE participation, all WBE participation, or a combination of MBE and WBE participation.

**Directory of Transportation Firms (Directory)**

Real-time information is available about firms doing business with the Department and firms that are certified through NCUCP in the Directory of Transportation Firms. Only firms identified in the Directory as MBE and WBE certified shall be used to meet the Combined MBE/WBE Goal. The Directory can be found at the following link.

<https://www.ebs.nc.gov/VendorDirectory/default.html>

The listing of an individual firm in the directory shall not be construed as an endorsement of the firm's capability to perform certain work.

**Listing of MBE/WBE Subcontractors**

At the time of bid, bidders shall submit all MBE and WBE participation that they anticipate to use during the life of the contract. Only those identified to meet the Combined MBE/WBE Goal will be considered committed, even though the listing shall include both committed MBE/WBE subcontractors and additional MBE/WBE subcontractors. Any additional MBE/WBE subcontractor participation above the goal will follow the banking guidelines found elsewhere in this provision. All other additional MBE/WBE subcontractor participation submitted at the time of bid will be used toward the Department's overall race-neutral goals. Only those firms with current MBE and WBE certification at the time of bid opening will be acceptable for listing in the bidder's submittal of MBE and WBE participation. The Contractor shall indicate the following required information:

**(A) Electronic Bids**

Bidders shall submit a listing of MBE and WBE participation in the appropriate section of the electronic submittal file.

- (1) Submit the names and addresses of MBE and WBE firms identified to participate in the contract. If the bidder uses the updated listing of MBE and WBE firms shown in the electronic submittal file, the bidder may use the dropdown menu to access the name and address of the firms.

- (2) Submit the contract line numbers of work to be performed by each MBE and WBE firm. When no figures or firms are entered, the bidder will be considered to have no MBE or WBE participation.
- (3) The bidder shall be responsible for ensuring that the MBE and WBE are certified at the time of bid by checking the Directory of Transportation Firms. If the firm is not certified at the time of the bid-letting, that MBE's or WBE's participation will not count towards achieving the Combined MBE/WBE goal.

(B) Paper Bids

- (1) *If the Combined MBE/WBE Goal is more than zero,*
  - (a) Bidders, at the time the bid proposal is submitted, shall submit a listing of MBE/WBE participation, including the names and addresses on *Listing of MBE and WBE Subcontractors* contained elsewhere in the contract documents in order for the bid to be considered responsive. Bidders shall indicate the total dollar value of the MBE and WBE participation for the contract.
  - (b) If bidders have no MBE or WBE participation, they shall indicate this on the *Listing of MBE and WBE Subcontractors* by entering the word "None" or the number "0." This form shall be completed in its entirety. **Blank forms will not be deemed to represent zero participation.** Bids submitted that do not have MBE and WBE participation indicated on the appropriate form will not be read publicly during the opening of bids. The Department will not consider these bids for award and the proposal will be rejected.
  - (c) The bidder shall be responsible for ensuring that the MBE/WBE is certified at the time of bid by checking the Directory of Transportation Firms. If the firm is not certified at the time of the bid-letting, that MBE's or WBE's participation will not count towards achieving the Combined MBE/WBE Goal.
- (2) *If the Combined MBE/WBE Goal is zero,* entries on the *Listing of MBE and WBE Subcontractors* are not required for the zero goal, however any MBE or WBE participation that is achieved during the project shall be reported in accordance with requirements contained elsewhere in the special provision.

**MBE or WBE Prime Contractor**

When a certified MBE or WBE firm bids on a contract that contains a Combined MBE/WBE goal, the firm is responsible for meeting the goal or making good faith efforts to meet the goal, just like any other bidder. In most cases, a MBE or WBE bidder on a contract will meet the Combined MBE/WBE Goal by virtue of the work it performs on the contract with its own forces. However, all the work that is performed by the MBE or WBE bidder and any other similarly certified subcontractors will count toward the goal. The MBE or WBE bidder shall list itself along with any MBE or WBE subcontractors, if any, in order to receive credit toward the goal.

MBE/WBE prime contractors shall also follow Sections A and B listed under *Listing of MBE/WBE Subcontractor* just as a non-MBE/WBE bidder would.

**Written Documentation – Letter of Intent**

The bidder shall submit written documentation for each MBE/WBE that will be used to meet the Combined MBE/WBE Goal of the contract, indicating the bidder's commitment to use the MBE/WBE in the contract. This documentation shall be submitted on the Department's form titled *Letter of Intent*.

The documentation shall be received in the office of the State Contractor Utilization Engineer or at DBE@ncdot.gov no later than 10:00 a.m. of the sixth calendar day following opening of bids, unless the sixth day falls on an official state holiday. In that situation, it is due in the office of the State Contractor Utilization Engineer no later than 10:00 a.m. on the next official state business day.

If the bidder fails to submit the Letter of Intent from each committed MBE and WBE to be used toward the Combined MBE/WBE Goal, or if the form is incomplete (i.e. both signatures are not present), the MBE/WBE participation will not count toward meeting the Combined MBE/WBE Goal. If the lack of this participation drops the commitment below the Combined MBE/WBE Goal, the Contractor shall submit evidence of good faith efforts for the goal, completed in its entirety, to the State Contractor Utilization Engineer or DBE@ncdot.gov no later than 10:00 a.m. on the eighth calendar day following opening of bids, unless the eighth day falls on an official state holiday. In that situation, it is due in the office of the State Contractor Utilization Engineer no later than 10:00 a.m. on the next official state business day.

**Banking MBE/WBE Credit**

If the bid of the lowest responsive bidder exceeds \$500,000 and if the committed MBE/WBE participation submitted exceeds the algebraic sum of the Combined MBE /WBE Goal by \$1,000 or more, the excess will be placed on deposit by the Department for future use by the bidder. Separate accounts will be maintained for MBE and WBE participation and these may accumulate for a period not to exceed 24 months.

When the apparent lowest responsive bidder fails to submit sufficient participation by MBE and WBE firms to meet the advertised goal, as part of the good faith effort, the Department will consider allowing the bidder to withdraw funds to meet the Combined MBE/WBE Goal as long as there are adequate funds available from the bidder's MBE and WBE bank accounts.

**Submission of Good Faith Effort**

If the bidder fails to meet or exceed the Combined MBE/WBE Goal, the apparent lowest responsive bidder shall submit to the Department documentation of adequate good faith efforts made to reach that specific goal.

A hard copy and an electronic copy of this information shall be received in the office of the State Contractor Utilization Engineer or at DBE@ncdot.gov no later than 10:00 a.m. on the sixth calendar day following opening of bids unless the sixth day falls on an official state holiday. In that situation, it would be due in the office of the State Contractor Utilization Engineer no later than 10:00 a.m. on the next official state business day. If the contractor cannot send the information electronically, then one complete set and 5 copies of this information shall be received under the same time constraints above.

Note: Where the information submitted includes repetitious solicitation letters, it will be acceptable to submit a representative letter along with a distribution list of the firms that were solicited. Documentation of MBE/WBE quotations shall be a part of the good faith effort submittal. This documentation may include written subcontractor quotations, telephone log notations of verbal quotations, or other types of quotation documentation.

**Consideration of Good Faith Effort for Projects with a Combined MBE/WBE Goal More Than Zero**

Adequate good faith efforts mean that the bidder took all necessary and reasonable steps to achieve the goal which, by their scope, intensity, and appropriateness, could reasonably be expected to obtain sufficient MBE/WBE participation. Adequate good faith efforts also mean that the bidder actively and aggressively sought MBE/WBE participation. Mere *pro forma* efforts are not considered good faith efforts.

The Department will consider the quality, quantity, and intensity of the different kinds of efforts a bidder has made. Listed below are examples of the types of actions a bidder will take in making a good faith effort to meet the goals and are not intended to be exclusive or exhaustive, nor is it intended to be a mandatory checklist.

- (A) Soliciting through all reasonable and available means (e.g. attendance at pre-bid meetings, advertising, written notices, use of verifiable electronic means through the use of the NCDOT Directory of Transportation Firms) the interest of all certified MBEs/WBEs that are also prequalified subcontractors. The bidder must solicit this interest within at least 10 days prior to bid opening to allow the MBEs/WBEs to respond to the solicitation. Solicitation shall provide the opportunity to MBEs/WBEs within the Division and surrounding Divisions where the project is located. The bidder must determine with certainty if the MBEs/WBEs are interested by taking appropriate steps to follow up initial solicitations.

- (B) Selecting portions of the work to be performed by MBEs/WBEs in order to increase the likelihood that the Combined MBE/WBE Goal will be achieved.
  - (1) Where appropriate, break out contract work items into economically feasible units to facilitate MBE/WBE participation, even when the prime contractor might otherwise prefer to perform these work items with its own forces.
  - (2) Negotiate with subcontractors to assume part of the responsibility to meet the advertised goal when the work to be sublet includes potential for MBE/WBE participation (2<sup>nd</sup> and 3<sup>rd</sup> tier subcontractors).
- (C) Providing interested certified MBEs/WBEs that are also prequalified subcontractors with adequate information about the plans, specifications, and requirements of the contract in a timely manner to assist them in responding to a solicitation.
- (D)
  - (1) Negotiating in good faith with interested MBEs/WBEs. It is the bidder's responsibility to make a portion of the work available to MBE/WBE subcontractors and suppliers and to select those portions of the work or material needs consistent with the available MBE/WBE subcontractors and suppliers, so as to facilitate MBE/WBE participation. Evidence of such negotiation includes the names, addresses, and telephone numbers of MBEs/WBEs that were considered; a description of the information provided regarding the plans and specifications for the work selected for subcontracting; and evidence as to why additional agreements could not be reached for MBEs/WBEs to perform the work.
  - (2) A bidder using good business judgment would consider a number of factors in negotiating with subcontractors, including MBE/WBE subcontractors, and would take a firm's price and capabilities as well as the advertised goal into consideration. However, the fact that there may be some additional costs involved in finding and using MBEs/WBEs is not in itself sufficient reason for a bidder's failure to meet the contract goal, as long as such costs are reasonable. Also, the ability or desire of a prime contractor to perform the work of a contract with its own organization does not relieve the bidder of the responsibility to make good faith efforts. Bidding contractors are not, however, required to accept higher quotes from MBEs/WBEs if the price difference is excessive or unreasonable.
- (E) Not rejecting MBEs/WBEs as being unqualified without sound reasons based on a thorough investigation of their capabilities. The bidder's standing within its industry, membership in specific groups, organizations, or associates and political or social affiliations (for example, union vs. non-union employee status) are not legitimate causes for the rejection or non-solicitation of bids in the bidder's efforts to meet the project goal.
- (F) Making efforts to assist interested MBEs/WBEs in obtaining bonding, lines of credit, or insurance as required by the recipient or bidder.
- (G) Making efforts to assist interested MBEs/WBEs in obtaining necessary equipment, supplies, materials, or related assistance or services.



- (H) Effectively using the services of available minority/women community organizations; minority/women contractors' groups; Federal, State, and local minority/women business assistance offices; and other organizations as allowed on a case-by-case basis to provide assistance in the recruitment and placement of MBEs/WBEs. Contact within 7 days from the bid opening the Business Opportunity and Work Force Development Unit at BOWD@ncdot.gov to give notification of the bidder's inability to get MBE or WBE quotes.
- (I) Any other evidence that the bidder submits which shows that the bidder has made reasonable good faith efforts to meet the advertised goal.

In addition, the Department may take into account the following:

- (1) Whether the bidder's documentation reflects a clear and realistic plan for achieving the Combined MBE/WBE Goal.
- (2) The bidders' past performance in meeting the contract goal.
- (3) The performance of other bidders in meeting the advertised goal. For example, when the apparent successful bidder fails to meet the goal, but others meet it, you may reasonably raise the question of whether, with additional reasonable efforts the apparent successful bidder could have met the goal. If the apparent successful bidder fails to meet the advertised goal, but meets or exceeds the average MBE and WBE participation obtained by other bidders, the Department may view this, in conjunction with other factors, as evidence of the apparent successful bidder having made a good faith effort.

If the Department does not award the contract to the apparent lowest responsive bidder, the Department reserves the right to award the contract to the next lowest responsive bidder that can satisfy to the Department that the Combined MBE/WBE Goal can be met or that an adequate good faith effort has been made to meet the advertised goal.

### **Non-Good Faith Appeal**

The State Prequalification Engineer will notify the contractor verbally and in writing of non-good faith. A contractor may appeal a determination of non-good faith made by the Goal Compliance Committee. If a contractor wishes to appeal the determination made by the Committee, they shall provide written notification to the State Prequalification Engineer or at DBE@ncdot.gov. The appeal shall be made within 2 business days of notification of the determination of non-good faith.

**Counting MBE/WBE Participation Toward Meeting the Combined MBE/WBE Goal****(A) Participation**

The total dollar value of the participation by a committed MBE/WBE will be counted toward the contract goal requirements. The total dollar value of participation by a committed MBE/WBE will be based upon the value of work actually performed by the MBE/WBE and the actual payments to MBE/WBE firms by the Contractor.

**(B) Joint Checks**

Prior notification of joint check use shall be required when counting MBE/WBE participation for services or purchases that involves the use of a joint check. Notification shall be through submission of Form JC-1 (*Joint Check Notification Form*) and the use of joint checks shall be in accordance with the Department's Joint Check Procedures.

**(C) Subcontracts (Non-Trucking)**

A MBE/WBE may enter into subcontracts. Work that a MBE subcontracts to another MBE firm may be counted toward the anticipated MBE participation. The same holds true for work that a WBE subcontracts to another WBE firm. Work that a MBE/WBE subcontracts to a non-MBE/WBE firm does not count toward the contract goal requirement. It should be noted that every effort shall be made by MBE and WBE contractors to subcontract to the same certification (i.e., MBEs to MBEs and WBEs to WBEs), in order to fulfill the MBE or WBE participation breakdown. This, however, may not always be possible due to the limitation of firms in the area. If the MBE or WBE firm shows a good faith effort has been made to reach out to similarly certified firms and there is no interest or availability, and they can get assistance from other certified firms, the Engineer will not hold the prime responsible for meeting the individual MBE or WBE breakdown. If a MBE or WBE contractor or subcontractor subcontracts a significantly greater portion of the work of the contract than would be expected on the basis of standard industry practices, it shall be presumed that the MBE or WBE is not performing a commercially useful function.

**(D) Joint Venture**

When a MBE or WBE performs as a participant in a joint venture, the Contractor may count toward its contract goal requirement a portion of the total value of participation with the MBE or WBE in the joint venture, that portion of the total dollar value being a distinct clearly defined portion of work that the MBE or WBE performs with its forces.

**(E) Suppliers**

A contractor may count toward its MBE/ WBE requirement 60 percent of its expenditures for materials and supplies required to complete the contract and obtained from a MBE or WBE regular dealer and 100 percent of such expenditures from a MBE or WBE manufacturer.

(F) Manufacturers and Regular Dealers

A contractor may count toward its MBE/ WBE requirement the following expenditures to MBE/WBE firms that are not manufacturers or regular dealers:

- (1) The fees or commissions charged by a MBE/WBE firm for providing a *bona fide* service, such as professional, technical, consultant, or managerial services, or for providing bonds or insurance specifically required for the performance of a DOT-assisted contract, provided the fees or commissions are determined to be reasonable and not excessive as compared with fees and commissions customarily allowed for similar services.
- (2) With respect to materials or supplies purchased from a MBE/WBE, which is neither a manufacturer nor a regular dealer, count the entire amount of fees or commissions charged for assistance in the procurement of the materials and supplies, or fees or transportation charges for the delivery of materials or supplies required on a job site (but not the cost of the materials and supplies themselves), provided the fees are determined to be reasonable and not excessive as compared with fees customarily allowed for similar services.

**Commercially Useful Function**

(A) MBE/WBE Utilization

The Contractor may count toward its contract goal requirement only expenditures to MBEs and WBEs that perform a commercially useful function in the work of a contract. A MBE/WBE performs a commercially useful function when it is responsible for execution of the work of the contract and is carrying out its responsibilities by actually performing, managing, and supervising the work involved. To perform a commercially useful function, the MBE/WBE shall also be responsible with respect to materials and supplies used on the contract, for negotiating price, determining quality and quantity, ordering the material and installing (where applicable) and paying for the material itself. To determine whether a MBE/WBE is performing a commercially useful function, the Department will evaluate the amount of work subcontracted, industry practices, whether the amount the firm is to be paid under the contract is commensurate with the work it is actually performing and the MBE/WBE credit claimed for its performance of the work, and any other relevant factors. If it is determined that a MBE or WBE is not performing a Commercially Useful Function, the contractor may present evidence to rebut this presumption to the Department.

## (B) MBE/WBE Utilization in Trucking

The following factors will be used to determine if a MBE or WBE trucking firm is performing a commercially useful function:

- (1) The MBE/WBE shall be responsible for the management and supervision of the entire trucking operation for which it is responsible on a particular contract, and there shall not be a contrived arrangement for the purpose of meeting the Combined MBE/WBE Goal.
- (2) The MBE/WBE shall itself own and operate at least one fully licensed, insured, and operational truck used on the contract.
- (3) The MBE/WBE receives credit for the total value of the transportation services it provides on the contract using trucks it owns, insures, and operates using drivers it employs.
- (4) The MBE may subcontract the work to another MBE firm, including an owner-operator who is certified as a MBE. The same holds true that a WBE may subcontract the work to another WBE firm, including an owner-operator who is certified as a WBE. When this occurs, the MBE or WBE who subcontracts work receives credit for the total value of the transportation services the subcontracted MBE or WBE provides on the contract. It should be noted that every effort shall be made by MBE and WBE contractors to subcontract to the same certification (i.e., MBEs to MBEs and WBEs to WBEs), in order to fulfill the participation breakdown. This, however, may not always be possible due to the limitation of firms in the area. If the MBE or WBE firm shows a good faith effort has been made to reach out to similarly certified transportation service providers and there is no interest or availability, and they can get assistance from other certified providers, the Engineer will not hold the prime responsible for meeting the individual MBE or WBE participation breakdown.
- (5) The MBE/WBE may also subcontract the work to a non-MBE/WBE firm, including from an owner-operator. The MBE/WBE who subcontracts the work to a non-MBE/WBE is entitled to credit for the total value of transportation services provided by the non-MBE/WBE subcontractor not to exceed the value of transportation services provided by MBE/WBE-owned trucks on the contract. Additional participation by non-MBE/WBE subcontractors receives credit only for the fee or commission it receives as a result of the subcontract arrangement. The value of services performed under subcontract agreements between the MBE/WBE and the Contractor will not count towards the MBE/WBE contract requirement.
- (6) A MBE/WBE may lease truck(s) from an established equipment leasing business open to the general public. The lease must indicate that the MBE/WBE has exclusive use of and control over the truck. This requirement does not preclude the leased truck from working for others during the term of the lease with the consent of the MBE/WBE, so long as the lease gives the MBE/WBE absolute

priority for use of the leased truck. This type of lease may count toward the MBE/WBE's credit as long as the driver is under the MBE/WBE's payroll.

- (7) Subcontracted/leased trucks shall display clearly on the dashboard the name of the MBE/WBE that they are subcontracted/leased to and their own company name if it is not identified on the truck itself. Magnetic door signs are not permitted.

### **MBE/WBE Replacement**

When a Contractor has relied on a commitment to a MBE or WBE subcontractor (or an approved substitute MBE or WBE subcontractor) to meet all or part of a contract goal requirement, the contractor shall not terminate the MBE/WBE subcontractor for convenience. This includes, but is not limited to, instances in which the Contractor seeks to perform the work of the terminated subcontractor with another MBE/WBE subcontractor, a non-MBE/WBE subcontractor, or with the Contractor's own forces or those of an affiliate.

The Contractor must give notice in writing both by certified mail and email to the MBE/WBE subcontractor, with a copy to the Engineer of its intent to request to terminate and/or substitute, and the reason for the request. The Contractor must give the MBE/WBE subcontractor five (5) business days to respond to the Contractor's Notice of Intent to Request Termination and/or Substitution. If the MBE/WBE subcontractor objects to the intended termination/substitution, the MBE/WBE, within five (5) business days must advise the Contractor and the Department of the reasons why the action should not be approved. The five-day notice period shall begin on the next business day after written notice is provided to the MBE/WBE subcontractor.

A committed MBE/WBE subcontractor may only be terminated after receiving the Department's written approval based upon a finding of good cause for the proposed termination and/or substitution. For purposes of this section, good cause shall include the following circumstances:

- (a) The listed MBE/WBE subcontractor fails or refuses to execute a written contract;
- (b) The listed MBE/WBE subcontractor fails or refuses to perform the work of its subcontract in a way consistent with normal industry standards. Provided, however, that good cause does not exist if the failure or refusal of the MBE/WBE subcontractor to perform its work on the subcontract results from the bad faith or discriminatory action of the prime contractor;
- (c) The listed MBE/WBE subcontractor fails or refuses to meet the prime contractor's reasonable, nondiscriminatory bond requirements;
- (d) The listed MBE/WBE subcontractor becomes bankrupt, insolvent, or exhibits credit unworthiness;
- (e) The listed MBE/WBE subcontractor is ineligible to work on public works projects because of suspension and debarment proceedings pursuant to 2 CFR Parts 180, 215 and 1,200 or applicable state law;
- (f) The listed MBE/WBE subcontractor is not a responsible contractor;
- (g) The listed MBE/WBE voluntarily withdraws from the project and provides written notice of withdrawal;
- (h) The listed MBE/WBE is ineligible to receive MBE/WBE credit for the type of work required;

- (i) A MBE/WBE owner dies or becomes disabled with the result that the listed MBE/WBE contractor is unable to complete its work on the contract;
- (j) Other documented good cause that compels the termination of the MBE/WBE subcontractor. Provided, that good cause does not exist if the prime contractor seeks to terminate a MBE/WBE it relied upon to obtain the contract so that the prime contractor can self-perform the work for which the MBE/WBE contractor was engaged or so that the prime contractor can substitute another MBE/WBE or non-MBE/WBE contractor after contract award.

The Contractor shall comply with the following for replacement of a committed MBE/WBE:

(A) Performance Related Replacement

When a committed MBE/WBE is terminated for good cause as stated above, an additional MBE/WBE that was submitted at the time of bid may be used to fulfill the MBE/WBE commitment to meet the Combined MBE/WBE Goal. A good faith effort will only be required for removing a committed MBE/WBE if there were no additional MBE/WBEs submitted at the time of bid to cover the same amount of work as the MBE/WBE that was terminated.

If a replacement MBE/WBE is not found that can perform at least the same amount of work as the terminated MBE/WBE, the Contractor shall submit a good faith effort documenting the steps taken. Such documentation shall include, but not be limited to, the following:

- (1) Copies of written notification to MBE/WBEs that their interest is solicited in contracting the work defaulted by the previous MBE/WBE or in subcontracting other items of work in the contract.
- (2) Efforts to negotiate with MBE/WBEs for specific subbids including, at a minimum:
  - (a) The names, addresses, and telephone numbers of MBE/WBEs who were contacted.
  - (b) A description of the information provided to MBE/WBEs regarding the plans and specifications for portions of the work to be performed.
- (3) A list of reasons why MBE/WBE quotes were not accepted.
- (4) Efforts made to assist the MBE/WBEs contacted, if needed, in obtaining bonding or insurance required by the Contractor.

(B) Decertification Replacement

- (1) When a committed MBE/WBE is decertified by the Department after the SAF (*Subcontract Approval Form*) has been received by the Department, the Department will not require the Contractor to solicit replacement MBE/WBE participation equal to the remaining work to be performed by the

decertified firm. The participation equal to the remaining work performed by the decertified firm will count toward the contract goal requirement.

- (2) When a committed MBE/WBE is decertified prior to the Department receiving the SAF (*Subcontract Approval Form*) for the named MBE/WBE firm, the Contractor shall take all necessary and reasonable steps to replace the MBE/WBE subcontractor with another MBE/WBE subcontractor to perform at least the same amount of work to meet the Combined MBE/WBE goal requirement. If a MBE/WBE firm is not found to do the same amount of work, a good faith effort must be submitted to NCDOT (see A herein for required documentation).
- (3) Exception: If the MBE/WBE's ineligibility is caused solely by its having exceeded the size standard during the performance of the contract, the Department will not require the Contractor to solicit replacement MBE/WBE participation equal to the remaining work to be performed by the decertified firm. The participation equal to the remaining work performed by the decertified firm will count toward the contract goal requirement and overall goal.

All requests for replacement of a committed MBE/WBE firm shall be submitted to the Engineer for approval on Form RF-1 (*DBE Replacement Request*). If the Contractor fails to follow this procedure, the Contractor may be disqualified from further bidding for a period of up to 6 months.

### **Changes in the Work**

When the Engineer makes changes that result in the reduction or elimination of work to be performed by a committed MBE/WBE, the Contractor will not be required to seek additional participation. When the Engineer makes changes that result in additional work to be performed by a MBE/WBE based upon the Contractor's commitment, the MBE/WBE shall participate in additional work to the same extent as the MBE/WBE participated in the original contract work.

When the Engineer makes changes that result in extra work, which has more than a minimal impact on the contract amount, the Contractor shall seek additional participation by MBEs/WBEs unless otherwise approved by the Engineer.

When the Engineer makes changes that result in an alteration of plans or details of construction, and a portion or all of the work had been expected to be performed by a committed MBE/WBE, the Contractor shall seek participation by MBEs/WBEs unless otherwise approved by the Engineer.

When the Contractor requests changes in the work that result in the reduction or elimination of work that the Contractor committed to be performed by a MBE/WBE, the Contractor shall seek additional participation by MBEs/WBEs equal to the reduced MBE/WBE participation caused by the changes.

**Reports and Documentation**

A SAF (*Subcontract Approval Form*) shall be submitted for all work which is to be performed by a MBE/WBE subcontractor. The Department reserves the right to require copies of actual subcontract agreements involving MBE/WBE subcontractors.

When using transportation services to meet the contract commitment, the Contractor shall submit a proposed trucking plan in addition to the SAF. The plan shall be submitted prior to beginning construction on the project. The plan shall include the names of all trucking firms proposed for use, their certification type(s), the number of trucks owned by the firm, as well as the individual truck identification numbers, and the line item(s) being performed.

Within 30 calendar days of entering into an agreement with a MBE/WBE for materials, supplies or services, not otherwise documented by the SAF as specified above, the Contractor shall furnish the Engineer a copy of the agreement. The documentation shall also indicate the percentage (60% or 100%) of expenditures claimed for MBE/WBE credit.

**Reporting Minority and Women Business Enterprise Participation**

The Contractor shall provide the Engineer with an accounting of payments made to all MBE/WBE firms, including material suppliers and contractors at all levels (prime, subcontractor, or second tier subcontractor). This accounting shall be furnished to the Engineer for any given month by the end of the following month. Failure to submit this information accordingly may result in the following action:

- (A) Withholding of money due in the next partial pay estimate; or
- (B) Removal of an approved contractor from the prequalified bidders' list or the removal of other entities from the approved subcontractors list.

While each contractor (prime, subcontractor, 2nd tier subcontractor) is responsible for accurate accounting of payments to MBEs/WBEs, it shall be the prime contractor's responsibility to report all monthly and final payment information in the correct reporting manner.

Failure on the part of the Contractor to submit the required information in the time frame specified may result in the disqualification of that contractor and any affiliate companies from further bidding until the required information is submitted.

Failure on the part of any subcontractor to submit the required information in the time frame specified may result in the disqualification of that contractor and any affiliate companies from being approved for work on future DOT projects until the required information is submitted.

Contractors reporting transportation services provided by non-MBE/WBE lessees shall evaluate the value of services provided during the month of the reporting period only.

At any time, the Engineer can request written verification of subcontractor payments.



The Contractor shall report the accounting of payments through the Department's Payment Tracking System.

### **Failure to Meet Contract Requirements**

Failure to meet contract requirements in accordance with Subarticle 102-15(J) of the *Standard Specifications* may be cause to disqualify the Contractor.

### **RESTRICTIONS ON ITS EQUIPMENT AND SERVICES:**

(11-17-20)

SP01 G090

All telecommunications, video or other ITS equipment or services installed or utilized on this project must be in conformance with UNIFORM ADMINISTRATIVE REQUIREMENTS, COST PRINCIPLES, AND AUDIT REQUIREMENTS FOR FEDERAL AWARDS **2 CFR, § 200.216 Prohibition on certain telecommunications and video surveillance services or equipment.**

### **USE OF UNMANNED AIRCRAFT SYSTEM (UAS):**

(8-20-19)

SP1 G092

The Contractor shall adhere to all Federal, State and Local regulations and guidelines for the use of Unmanned Aircraft Systems (UAS). This includes but is not limited to US 14 CFR Part 107 *Small UAS Rule*, NC GS 15A-300.2 *Regulation of launch and recovery sites*, NC GS 63-95 *Training required for the operation of unmanned aircraft systems*, NC GS 63-96 *Permit required for commercial operation of unmanned aircraft system*, and NCDOT UAS Policy. The required operator certifications include possessing a current Federal Aviation Administration (FAA) Remote Pilot Certificate, a NC UAS Operator Permit as well as operating a UAS registered with the FAA.

Prior to beginning operations, the Contractor shall complete the NCDOT UAS – Flight Operation Approval Form and submit it to the Engineer for approval. All UAS operations shall be approved by the Engineer prior to beginning the operations.

All contractors or subcontractors operating UAS shall have UAS specific general liability insurance to cover all operations under this contract.

The use of UAS is at the Contractor's discretion. No measurement or payment will be made for the use of UAS. In the event that the Department directs the Contractor to utilize UAS, payment will be in accordance with Article 104-7 Extra Work.

### **EQUIPMENT IDLING GUIDELINES:**

(1-19-21)

107

SP1 G096

Exercise reduced fuel consumption and reduced equipment emissions during the construction of all work associated with this contract. Employees engaged in the construction of this project should turn off vehicles when stopped for more than thirty (30) minutes and off-highway equipment should idle no longer than fifteen (15) consecutive minutes.

These guidelines for turning off vehicles and equipment when idling do not apply to:

1. Idling when queuing.
2. Idling to verify the vehicle is in safe operating condition.
3. Idling for testing, servicing, repairing or diagnostic purposes.
4. Idling necessary to accomplish work for which the vehicle was designed (such as operating a crane, mixing concrete, etc.).
5. Idling required to bring the machine system to operating temperature.
6. Emergency vehicles, utility company, construction, and maintenance vehicles where the engines must run to perform needed work.
7. Idling to ensure safe operation of the vehicle.
8. Idling when the propulsion engine is providing auxiliary power for other than heating or air conditioning. (such as hydraulic systems for pavers)
9. When specific traffic, safety, or emergency situations arise.
10. If the ambient temperature is less than 32 degrees Fahrenheit. Limited idling to provide for the safety of vehicle occupants (e.g. to run the heater).
11. If the ambient temperature is greater than 90 degrees Fahrenheit. Limited idling to provide for the safety of vehicle occupants of off-highway equipment (e.g. to run the air conditioning) no more than 30 minutes.
12. Diesel powered vehicles may idle for up to 30 minutes to minimize restart problems.

Any vehicle, truck, or equipment in which the primary source of fuel is natural gas or electricity is exempt from the idling limitations set forth in this special provision.

**MAINTENANCE OF THE PROJECT:**

(11-20-07)(Rev. 1-16-24)

104-10

SP1 G125

Revise the *Standard Specifications* as follows:

**Page 1-35, Article 104-10 Maintenance of the Project, line 3,** add the following after the first sentence of the first paragraph:

All guardrail/guiderail within the project limits shall be included in this maintenance.

**Page 1-35, Article 104-10 MAINTENANCE OF THE PROJECT, line 8,** add the following as the last sentence of the first paragraph:

The Contractor shall perform weekly inspections of guardrail and guiderail and shall report damages to the Engineer on the same day of the weekly inspection. *Where damaged guardrail or guiderail is repaired or replaced as a result of maintaining the project in accordance with this article, such repair or replacement shall be performed within 7 consecutive calendar days of such inspection report.*

**Page 1-35, Article 104-10 MAINTENANCE OF THE PROJECT, lines 20-22,** replace the last sentence of the last paragraph with the following:

The Contractor will not be directly compensated for any maintenance operations necessary, except for maintenance of guardrail/guiderail, as this work will be considered incidental to the work covered by the various contract items. The provisions of Article 104-7, Extra Work, and

Article 104-8, Compensation and Record Keeping will apply to authorized maintenance of guardrail/guiderail. Performance of weekly inspections of guardrail/guiderail, and the damage reports required as described above, will be considered to be an incidental part of the work being paid for by the various contract items.

**TWELVE MONTH GUARANTEE:**

(7-15-03)

108

SP1 G145

- (A) The Contractor shall guarantee materials and workmanship against latent and patent defects arising from faulty materials, faulty workmanship or negligence for a period of twelve months following the date of final acceptance of the work for maintenance and shall replace such defective materials and workmanship without cost to the Department. The Contractor will not be responsible for damage due to faulty design, normal wear and tear, for negligence on the part of the Department, and/or for use in excess of the design.
- (B) Where items of equipment or material carry a manufacturer's guarantee for any period in excess of twelve months, then the manufacturer's guarantee shall apply for that particular piece of equipment or material. The Department's first remedy shall be through the manufacturer although the Contractor is responsible for invoking the warranted repair work with the manufacturer. The Contractor's responsibility shall be limited to the term of the manufacturer's guarantee. NCDOT would be afforded the same warranty as provided by the Manufacturer.

This guarantee provision shall be invoked only for major components of work in which the Contractor would be wholly responsible for under the terms of the contract. Examples would include pavement structures, bridge components, and sign structures. This provision will not be used as a mechanism to force the Contractor to return to the project to make repairs or perform additional work that the Department would normally compensate the Contractor for. In addition, routine maintenance activities (i.e. mowing grass, debris removal, ruts in earth shoulders,) are not parts of this guarantee.

Appropriate provisions of the payment and/or performance bonds shall cover this guarantee for the project.

To ensure uniform application statewide the Division Engineer will forward details regarding the circumstances surrounding any proposed guarantee repairs to the Chief Engineer for review and approval prior to the work being performed.

**OUTSOURCING OUTSIDE THE USA:**

(9-21-04) (Rev. 5-16-06)

SP1 G150

All work on consultant contracts, services contracts, and construction contracts shall be performed in the United States of America. No work shall be outsourced outside of the United States of America.

*Outsourcing* for the purpose of this provision is defined as the practice of subcontracting labor, work, services, staffing, or personnel to entities located outside of the United States.

The North Carolina Secretary of Transportation shall approve exceptions to this provision in writing.

**NOTE TO CONTRACTOR:**

Any concrete waste water shall be disposed of in accordance with the Department of Environmental Quality General Permit NCG01.

**PROJECT SPECIAL PROVISIONS****ROADWAY****PRICE ADJUSTMENT - ASPHALT BINDER FOR PLANT MIX:**

(11-21-00)(Rev. 1-16-24)

620

SP6 R25

Price adjustments for asphalt binder for plant mix will be made in accordance with Section 620 of the *Standard Specifications*.

The base price index for asphalt binder for plant mix is **\$ 596.88** per ton.

This base price index represents an average of F.O.B. selling prices of asphalt binder at supplier's terminals on **May 1, 2024**.

**FINAL SURFACE TESTING NOT REQUIRED:**

(5-18-04) (Rev. 2-16-16)

610

SP6 R45

Final surface testing is not required on this project in accordance with Section 610-13, *Final Surface Testing and Acceptance*.

**CONES:**

(3-19-24)

1135

SP11 R35

Revise the *Standard Specifications* as follows:

**Page 11-11, Article 1135-3 CONSTRUCTION METHODS, lines 19-20**, delete the third sentence of the first paragraph, "Do not use cones in the upstream taper of lane or shoulder closures for multi-lane roadways."

**STANDARD SPECIAL PROVISION**  
**AVAILABILITY OF FUNDS – TERMINATION OF CONTRACTS**

(5-20-08)(Rev. 1-16-24)

Z-2

*General Statute 143C-6-11. (h) Highway Appropriation* is hereby incorporated verbatim in this contract as follows:

(h) Amounts Encumbered. – Transportation project appropriations may be encumbered in the amount of allotments made to the Department of Transportation by the Director for the estimated payments for transportation project contract work to be performed in the appropriation fiscal year. The allotments shall be multiyear allotments and shall be based on estimated revenues and shall be subject to the maximum contract authority contained in *General Statute 143C-6-11(c)*. Payment for transportation project work performed pursuant to contract in any fiscal year other than the current fiscal year is subject to appropriations by the General Assembly. Transportation project contracts shall contain a schedule of estimated completion progress, and any acceleration of this progress shall be subject to the approval of the Department of Transportation provided funds are available. The State reserves the right to terminate or suspend any transportation project contract, and any transportation project contract shall be so terminated or suspended if funds will not be available for payment of the work to be performed during that fiscal year pursuant to the contract. In the event of termination of any contract, the contractor shall be given a written notice of termination at least 60 days before completion of scheduled work for which funds are available. In the event of termination, the contractor shall be paid for the work already performed in accordance with the contract specifications.

Payment will be made on any contract terminated pursuant to the special provision in accordance with Subarticle 108-13(D) of the *Standard Specifications*.

**STANDARD SPECIAL PROVISION**  
**NCDOT GENERAL SEED SPECIFICATION FOR SEED QUALITY**

(5-17-11)

Z-3

Seed shall be sampled and tested by the North Carolina Department of Agriculture and Consumer Services, Seed Testing Laboratory. When said samples are collected, the vendor shall supply an independent laboratory report for each lot to be tested. Results from seed so sampled shall be final. Seed not meeting the specifications shall be rejected by the Department of Transportation and shall not be delivered to North Carolina Department of Transportation warehouses. If seed has been delivered it shall be available for pickup and replacement at the supplier's expense.

Any re-labeling required by the North Carolina Department of Agriculture and Consumer Services, Seed Testing Laboratory, that would cause the label to reflect as otherwise specified herein shall be rejected by the North Carolina Department of Transportation.

Seed shall be free from seeds of the noxious weeds Johnsongrass, Balloonvine, Jimsonweed, Witchweed, Itchgrass, Serrated Tussock, Showy Crotalaria, Smooth Crotalaria, Sicklepod, Sandbur, Wild Onion, and Wild Garlic. Seed shall not be labeled with the above weed species on the seed analysis label. Tolerances as applied by the Association of Official Seed Analysts will NOT be allowed for the above noxious weeds except for Wild Onion and Wild Garlic.

Tolerances established by the Association of Official Seed Analysts will generally be recognized. However, for the purpose of figuring pure live seed, the found pure seed and found germination percentages as reported by the North Carolina Department of Agriculture and Consumer Services, Seed Testing Laboratory will be used. Allowances, as established by the NCDOT, will be recognized for minimum pure live seed as listed on the following pages.

The specifications for restricted noxious weed seed refers to the number per pound as follows:

<b><u>Restricted Noxious Weed</u></b>	<b><u>Limitations per Lb. Of Seed</u></b>	<b><u>Restricted Noxious Weed</u></b>	<b><u>Limitations per Lb. of Seed</u></b>
Blessed Thistle	4 seeds	Cornflower (Ragged Robin)	27 seeds
Cocklebur	4 seeds	Texas Panicum	27 seeds
Spurred Anoda	4 seeds	Bracted Plantain	54 seeds
Velvetleaf	4 seeds	Buckhorn Plantain	54 seeds
Morning-glory	8 seeds	Broadleaf Dock	54 seeds
Corn Cockle	10 seeds	Curly Dock	54 seeds
Wild Radish	12 seeds	Dodder	54 seeds
Purple Nutsedge	27 seeds	Giant Foxtail	54 seeds
Yellow Nutsedge	27 seeds	Horsenettle	54 seeds
Canada Thistle	27 seeds	Quackgrass	54 seeds
Field Bindweed	27 seeds	Wild Mustard	54 seeds
Hedge Bindweed	27 seeds		

Seed of Pensacola Bahiagrass shall not contain more than 7% inert matter, Kentucky Bluegrass, Centipede and Fine or Hard Fescue shall not contain more than 5% inert matter whereas a

maximum of 2% inert matter will be allowed on all other kinds of seed. In addition, all seed shall not contain more than 2% other crop seed nor more than 1% total weed seed. The germination rate as tested by the North Carolina Department of Agriculture shall not fall below 70%, which includes both dormant and hard seed. Seed shall be labeled with not more than 7%, 5% or 2% inert matter (according to above specifications), 2% other crop seed and 1% total weed seed.

Exceptions may be made for minimum pure live seed allowances when cases of seed variety shortages are verified. Pure live seed percentages will be applied in a verified shortage situation. Those purchase orders of deficient seed lots will be credited with the percentage that the seed is deficient.

FURTHER SPECIFICATIONS FOR EACH SEED GROUP ARE GIVEN BELOW:

Minimum 85% pure live seed; maximum 1% total weed seed; maximum 2% total other crop seed; maximum 144 restricted noxious weed seed per pound. Seed less than 83% pure live seed will not be approved.

Sericea Lespedeza  
Oats (seeds)

Minimum 80% pure live seed; maximum 1% total weed seed; maximum 2% total other crop; maximum 144 restricted noxious weed seed per pound. Seed less than 78% pure live seed will not be approved.

Tall Fescue (all approved varieties)	Bermudagrass
Kobe Lespedeza	Browntop Millet
Korean Lespedeza	German Millet – Strain R
Weeping Lovegrass	Clover – Red/White/Crimson
Carpetgrass	

Minimum 78% pure live seed; maximum 1% total weed seed; maximum 2% total other crop seed; maximum 144 restricted noxious weed seed per pound. Seed less than 76% pure live seed will not be approved.

Common or Sweet Sundangrass

Minimum 76% pure live seed; maximum 1% total weed seed; maximum 2% total other crop seed; maximum 144 restricted noxious weed seed per pound. Seed less than 74% pure live seed will not be approved.

Rye (grain; all varieties)  
Kentucky Bluegrass (all approved varieties)  
Hard Fescue (all approved varieties)  
Shrub (bicolor) Lespedeza

Minimum 70% pure live seed; maximum 1% total weed seed; maximum 2% total other crop seed; maximum 144 noxious weed seed per pound. Seed less than 70% pure live seed will not be approved.

Centipedegrass	Japanese Millet
Crownvetch	Reed Canary Grass



Pensacola Bahiagrass  
Creeping Red Fescue

Zoysia

Minimum 70% pure live seed; maximum 1% total weed seed; maximum 2% total other crop seed; maximum 5% inert matter; maximum 144 restricted noxious weed seed per pound.

Barnyard Grass  
Big Bluestem  
Little Bluestem  
Bristly Locust  
Birdsfoot Trefoil  
Indiangrass  
Orchardgrass  
Switchgrass  
Yellow Blossom Sweet Clover

**STANDARD SPECIAL PROVISION**  
**ERRATA**

(1-16-24)

Z-4

Revise the 2024 *Standard Specifications* as follows:

**Division 3**

**Page 3-5, Article 305-2 MATERIALS, after line 16,** replace " 1032-3(A)(7)" with "1032-3" and add the item "Galvanized Corrugated Steel Pipe" with Section "1032-3".

**Page 3-6, Article 310-2 MATERIALS, after line 9,** add the item "Galvanized Corrugated Steel Pipe" with Section "1032-3".

**Division 9**

**Page 9-17, Article 904-4 MEASUREMENT AND PAYMENT, prior to line 1,** replace " Sign Erection, Relocate Type (Ground Mounted)" with "Sign Erection, Relocate Type \_\_\_ (Ground Mounted)".

**Division 10**

**Page 10-51, Article 1024-4 WATER, prior to line 1,** delete the "unpopulated blank row" in Table 1024-2 between "Time of set, deviation from control" and "Chloride Ion Content, Max.".

**Page 10-170, Subarticle 1081-1(C) Requirements, line 4,** replace "maximum" with "minimum".

**Division 11**

**Page 11-15, Article 1160-4 MEASUREMENT AND PAYMENT, line 24,** replace "Where barrier units are moved more than one" with "Where barrier units are moved more than once".

**Division 15**

**Page 15-10, Article 1515-4 MEASUREMENT AND PAYMENT, lines 11,** replace " All piping" with "All labor, the manhole, other materials, excavation, backfilling, piping".

**Division 16**

**Page 16-14, Article 1633-5 MEASUREMENT AND PAYMENT, line 20-24 and prior to line 25,** delete and replace with the following " *Flocculant* will be measured and paid in accordance with Article 1642-5 applied to the temporary rock silt checks."

**Page 16-3, Article 1609-2 MATERIALS, after line 26,** replace "Type 4" with "Type 4a".

**Page 16-25, Article 1644-2 MATERIALS, after line 22,** replace "Type 4" with "Type 4a".

**STANDARD SPECIAL PROVISION****PLANT AND PEST QUARANTINES****(Imported Fire Ant, Gypsy Moth, Witchweed, Emerald Ash Borer, Guava Root Knot Nematode, And Other Noxious Weeds)**

(3-18-03) (Rev. 5-21-19)

Z-04a

**Within Quarantined Area**

This project may be within a county regulated for plant and/or pests. If the project or any part of the Contractor's operations is located within a quarantined area, thoroughly clean all equipment prior to moving out of the quarantined area. Comply with federal/state regulations by obtaining a certificate or limited permit for any regulated article moving from the quarantined area.

**Originating in a Quarantined County**

Obtain a certificate or limited permit issued by the N.C. Department of Agriculture/United States Department of Agriculture. Have the certificate or limited permit accompany the article when it arrives at the project site.

**Contact**

Contact the N.C. Department of Agriculture/United States Department of Agriculture at 1-800-206-9333, 919-707-3730, or <https://www.ncagr.gov/plantindustry/Plant/quaran/table2.htm> to determine those specific project sites located in the quarantined area or for any regulated article used on this project originating in a quarantined county.

**Regulated Articles Include**

1. Soil, sand, gravel, compost, peat, humus, muck, and decomposed manure, separately or with other articles. This includes movement of articles listed above that may be associated with cut/waste, ditch pulling, and shoulder cutting.
2. Plants with roots including grass sod.
3. Plant crowns and roots.
4. Bulbs, corms, rhizomes, and tubers of ornamental plants.
5. Hay, straw, fodder, and plant litter of any kind.
6. Clearing and grubbing debris.
7. Used agricultural cultivating and harvesting equipment.
8. Used earth-moving equipment.
9. Any other products, articles, or means of conveyance, of any character, if determined by an inspector to present a hazard of spreading imported fire ant, gypsy moth, witchweed, emerald ash borer, guava root knot nematode, or other noxious weeds.

**STANDARD SPECIAL PROVISION**

**MINIMUM WAGES**

(7-21-09)

Z-5

**FEDERAL:** The Fair Labor Standards Act provides that with certain exceptions every employer shall pay wages at the rate of not less than SEVEN DOLLARS AND TWENTY FIVE CENTS (\$7.25) per hour.

**STATE:** The North Carolina Minimum Wage Act provides that every employer shall pay to each of his employees, wages at a rate of not less than SEVEN DOLLARS AND TWENTY FIVE CENTS (\$7.25) per hour.

The minimum wage paid to all skilled labor employed on this contract shall be SEVEN DOLLARS AND TWENTY FIVE CENTS (\$7.25) per hour.

The minimum wage paid to all intermediate labor employed on this contract shall be SEVEN DOLLARS AND TWENTY FIVE CENTS (\$7.25) per hour.

The minimum wage paid to all unskilled labor on this contract shall be SEVEN DOLLARS AND TWENTY FIVE CENTS (\$7.25) per hour.

This determination of the intent of the application of this act to the contract on this project is the responsibility of the Contractor.

The Contractor shall have no claim against the Department of Transportation for any changes in the minimum wage laws, Federal or State. It is the responsibility of the Contractor to keep fully informed of all Federal and State Laws affecting his contract.

**STANDARD SPECIAL PROVISION****TITLE VI AND NONDISCRIMINATION:**

(6-28-77)(Rev 1/16/2024)

Z-6

The North Carolina Department of Transportation is committed to carrying out the U.S. Department of Transportation's policy of ensuring nondiscrimination in the award and administration of contracts.

The provisions of this section related to United States Department of Transportation (US DOT) Order 1050.2A, Title 49 Code of Federal Regulations (CFR) part 21, 23 United States Code (U.S.C.) 140 and 23 CFR part 200 (or 49 CFR 303, 49 U.S.C. 5332 or 49 U.S.C. 47123) are applicable to all North Carolina Department of Transportation (NCDOT) contracts and to all related subcontracts, material supply, engineering, architectural and other service contracts, regardless of dollar amount. Any Federal provision that is specifically required not specifically set forth is hereby incorporated by reference.

**(1) Title VI Assurances (USDOT Order 1050.2A, Appendix A)**

During the performance of this contract, the contractor, for itself, its assignees, and successors in interest (hereinafter referred to as the "contractor") agrees as follows:

**(a) Compliance with Regulations**

The contractor (hereinafter includes consultants) shall comply with the Acts and the Regulations relative to Nondiscrimination in Federally-assisted programs of the U.S. Department of Transportation, Federal Highway Administration (FHWA), as they may be amended from time to time, which are herein incorporated by reference and made a part of this contract.

**(b) Nondiscrimination**

The contractor, with regard to the work performed by it during the contract, shall not discriminate on the grounds of race, color, or national origin in the selection and retention of subcontractors, including procurements of materials and leases of equipment. The contractor shall not participate directly or indirectly in the discrimination prohibited by the Acts and the Regulations, including employment practices when the contract covers any activity, project, or program set forth in Appendix B of 49 CFR Part 21.

**(c) Solicitations for Subcontractors, Including Procurements of Materials and Equipment**

In all solicitations, either by competitive bidding, or negotiation made by the contractor for work to be performed under a subcontract, including procurements of materials, or leases of equipment, each potential subcontractor or supplier shall be notified by the contractor of the contractor's obligations under this contract and the Acts and the Regulations relative to Nondiscrimination on the grounds of race, color, or national origin.

**(d) Information and Reports**

The contractor shall provide all information and reports required by the Acts, the Regulations, and directives issued pursuant thereto and shall permit access to its books, records, accounts, other sources of information, and its facilities as may be determined by the Recipient or the FHWA to be pertinent to ascertain compliance with such Acts, Regulations, and instructions. Where any information required of a contractor is in the exclusive possession of another who fails or refuses to furnish the information, the contractor shall so certify to the Recipient or the FHWA, as appropriate, and shall set forth what efforts it has made to obtain the information.

(e) Sanctions for Noncompliance:

In the event of a contractor's noncompliance with the Non-discrimination provisions of this contract, the Recipient will impose such contract sanctions as it and/or the FHWA may determine to be appropriate, including, but not limited to:

- (i) Withholding payments to the contractor under the contract until the contractor complies; and/or
- (ii) Cancelling, terminating, or suspending a contract, in whole or in part.

(f) Incorporation of Provisions

The contractor shall include the provisions of paragraphs (a) through (f) in every subcontract, including procurements of materials and leases of equipment, unless exempt by the Acts, the Regulations and directives issued pursuant thereto. The contractor shall take action with respect to any subcontract or procurement as the Recipient or the FHWA may direct as a means of enforcing such provisions including sanctions for noncompliance. Provided, that if the contractor becomes involved in, or is threatened with litigation by a subcontractor, or supplier because of such direction, the contractor may request the Recipient to enter into any litigation to protect the interests of the Recipient. In addition, the contractor may request the United States to enter into the litigation to protect the interests of the United States.

**(2) Title VI Nondiscrimination Program (23 CFR 200.5(p))**

The North Carolina Department of Transportation (NCDOT) has assured the USDOT that, as a condition to receiving federal financial assistance, NCDOT will comply with Title VI of the Civil Rights Act of 1964 and all requirements imposed by Title 49 CFR part 21 and related nondiscrimination authorities to ensure that no person shall, on the ground of race, color, national origin, limited English proficiency, sex, age, or disability (including religion/creed or income-level, where applicable), be excluded from participation in, be denied the benefits of, or be subjected to discrimination under any programs, activities, or services conducted or funded by NCDOT. Contractors and other organizations under contract or agreement with NCDOT must also comply with Title VI and related authorities, therefore:

- (a) During the performance of this contract or agreement, contractors (e.g., subcontractors, consultants, vendors, prime contractors) are responsible for complying with NCDOT's Title VI Program. Contractors are not required to prepare or submit Title VI Programs. To comply with this section, the prime contractor shall:
  1. Post NCDOT's Notice of Nondiscrimination and the Contractor's own Equal Employment Opportunity (EEO) Policy in conspicuous locations accessible to all employees, applicants and subcontractors on the jobsite.

2. Physically incorporate the required Title VI clauses into all subcontracts on federally-assisted and state-funded NCDOT projects, and ensure inclusion by subcontractors into all lower-tier subcontracts.
  3. Required Solicitation Language. The Contractor shall include the following notification in all solicitations for bids and requests for work or material, regardless of funding source:

“The North Carolina Department of Transportation, in accordance with the provisions of Title VI of the Civil Rights Act of 1964 (78 Stat. 252, 42 U.S.C. §§ 2000d to 2000d-4) and the Regulations, hereby notifies all bidders that it will affirmatively ensure that any contract entered into pursuant to this advertisement, disadvantaged business enterprises will be afforded full and fair opportunity to submit bids in response to this invitation and will not be discriminated against on the grounds of race, color, or national origin in consideration for an award. In accordance with other related nondiscrimination authorities, bidders and contractors will also not be discriminated against on the grounds of sex, age, disability, low-income level, creed/religion, or limited English proficiency in consideration for an award.”
  4. Physically incorporate the FHWA-1273, in its entirety, into all subcontracts and subsequent lower tier subcontracts on Federal-aid highway construction contracts only.
  5. Provide language assistance services (i.e., written translation and oral interpretation), free of charge, to LEP employees and applicants. Contact NCDOT OCR for further assistance, if needed.
  6. For assistance with these Title VI requirements, contact the NCDOT Title VI Nondiscrimination Program at 1-800-522-0453.
- (b) Subrecipients (e.g. cities, counties, LGAs, planning organizations) may be required to prepare and submit a Title VI Plan to NCDOT, including Title VI Assurances and/or agreements. Subrecipients must also ensure compliance by their contractors and subrecipients with Title VI. (23 CFR 200.9(b)(7))
  - (c) If reviewed or investigated by NCDOT, the contractor or subrecipient agrees to take affirmative action to correct any deficiencies found within a reasonable time period, not to exceed 90 calendar days, unless additional time is granted by NCDOT. (23 CFR 200.9(b)(15))
  - (d) The Contractor is responsible for notifying subcontractors of NCDOT’s External Discrimination Complaints Process.
    1. Applicability

Title VI and related laws protect participants and beneficiaries (e.g., members of the public and contractors) from discrimination by NCDOT employees, subrecipients and contractors, regardless of funding source.

## 2. Eligibility

Any person—or class of persons—who believes he/she has been subjected to discrimination based on race, color, national origin, Limited English Proficiency (LEP), sex, age, or disability (and religion in the context of employment, aviation, or transit) may file a written complaint. The law also prohibits intimidation or retaliation of any sort.

## 3. Time Limits and Filing Options

Complaints may be filed by the affected individual(s) or a representative and must be filed no later than 180 calendar days after the following:

- (i) The date of the alleged act of discrimination; or
- (ii) The date when the person(s) became aware of the alleged discrimination; or
- (iii) Where there has been a continuing course of conduct, the date on which that conduct was discontinued or the latest instance of the conduct.

Title VI and related discrimination complaints may be submitted to the following entities:

- North Carolina Department of Transportation, Office of Civil Rights, Title VI Program, 1511 Mail Service Center, Raleigh, NC 27699-1511; toll free 1-800-522-0453
- Federal Highway Administration, North Carolina Division Office, 310 New Bern Avenue, Suite 410, Raleigh, NC 27601, 919-747-7010
- US Department of Transportation, Departmental Office of Civil Rights, External Civil Rights Programs Division, 1200 New Jersey Avenue, SE, Washington, DC 20590; 202-366-4070

## 4. Format for Complaints

Complaints must be in writing and signed by the complainant(s) or a representative, and include the complainant's name, address, and telephone number. Complaints received by fax or e-mail will be acknowledged and processed. Allegations received by telephone will be reduced to writing and provided to the complainant for confirmation or revision before processing. Complaints will be accepted in other languages, including Braille.

## 5. Discrimination Complaint Form

Contact NCDOT Civil Rights to receive a full copy of the Discrimination Complaint Form and procedures.

## 6. Complaint Basis

Allegations must be based on issues involving race, color, national origin (LEP), sex, age, disability, or religion (in the context of employment, aviation or transit). "Basis" refers to the complainant's membership in a protected group category.



**TABLE 103-1  
COMPLAINT BASIS**

<b>Protected Categories</b>	<b>Definition</b>	<b>Examples</b>	<b>Applicable Nondiscrimination Authorities</b>
Race and Ethnicity	An individual belonging to one of the accepted racial groups; or the perception, based usually on physical characteristics that a person is a member of a racial group	Black/African American, Hispanic/Latino, Asian, American Indian/Alaska Native, Native Hawaiian/Pacific Islander, White	Title VI of the Civil Rights Act of 1964; 49 CFR Part 21; 23 CFR 200; 49 U.S.C. 5332(b); 49 U.S.C. 47123. ( <i>Executive Order 13166</i> )
Color	Color of skin, including shade of skin within a racial group	Black, White, brown, yellow, etc.	
National Origin ( <i>Limited English Proficiency</i> )	Place of birth. Citizenship is not a factor. ( <i>Discrimination based on language or a person's accent is also covered</i> )	Mexican, Cuban, Japanese, Vietnamese, Chinese	
Sex	Gender. The sex of an individual. <i>Note: Sex under this program does not include sexual orientation.</i>	Women and Men	1973 Federal-Aid Highway Act; 49 U.S.C. 5332(b); 49 U.S.C. 47123.
Age	Persons of any age	21-year-old person	Age Discrimination Act of 1975 49 U.S.C. 5332(b); 49 U.S.C. 47123.
Disability	Physical or mental impairment, permanent or temporary, or perceived.	Blind, alcoholic, para-amputee, epileptic, diabetic, arthritic	Section 504 of the Rehabilitation Act of 1973; Americans with Disabilities Act of 1990
Religion (in the context of employment) ( <i>Religion/ Creed in all aspects of any aviation or transit-related construction</i> )	An individual belonging to a religious group; or the perception, based on distinguishable characteristics that a person is a member of a religious group. In practice, actions taken as a result of the moral and ethical beliefs as to what is right and wrong, which are sincerely held with the strength of traditional religious views. <i>Note: Does not have to be associated with a recognized religious group or church; if an individual sincerely holds to the belief, it is a protected religious practice.</i>	Muslim, Christian, Sikh, Hindu, etc.	Title VII of the Civil Rights Act of 1964; 23 CFR 230; FHWA-1273 Required Contract Provisions. ( <i>49 U.S.C. 5332(b); 49 U.S.C. 47123</i> )

### (3) Pertinent Nondiscrimination Authorities

During the performance of this contract, the contractor, for itself, its assignees, and successors in interest agrees to comply with the following non-discrimination statutes and authorities, including, but not limited to:

- (a) Title VI of the Civil Rights Act of 1964 (42 U.S.C. § 2000d et seq., 78 stat. 252), (prohibits discrimination on the basis of race, color, national origin); and 49 CFR Part 21.

- (b) The Uniform Relocation Assistance and Real Property Acquisition Policies Act of 1970, (42 U.S.C. § 4601), (prohibits unfair treatment of persons displaced or whose property has been acquired because of Federal or Federal-aid programs and projects);
- (c) Federal-Aid Highway Act of 1973, (23 U.S.C. § 324 et seq.), (prohibits discrimination on the basis of sex);
- (d) Section 504 of the Rehabilitation Act of 1973, (29 U.S.C. § 794 et seq.), as amended, (prohibits discrimination on the basis of disability) and 49 CFR Part 27;
- (e) The Age Discrimination Act of 1975, as amended, (42 U.S.C. § 6101 et seq.), (prohibits discrimination on the basis of age);
- (f) Airport and Airway Improvement Act of 1982, (49 USC § 471, Section 47123), as amended, (prohibits discrimination based on race, creed, color, national origin, or sex);
- (g) The Civil Rights Restoration Act of 1987, (PL 100-209), (Broadened the scope, coverage and applicability of Title VI of the Civil Rights Act of 1964, The Age Discrimination Act of 1975 and Section 504 of the Rehabilitation Act of 1973, by expanding the definition of the terms "programs or activities" to include all of the programs or activities of the Federal-aid recipients, sub-recipients and contractors, whether such programs or activities are Federally funded or not);
- (h) Titles II and III of the Americans with Disabilities Act, which prohibit discrimination on the basis of disability in the operation of public entities, public and private transportation systems, places of public accommodation, and certain testing entities (42 U.S.C. §§ 12131-12189) as implemented by Department of Transportation regulations at 49 C.F.R. parts 37 and 38;
- (i) The Federal Aviation Administration's Nondiscrimination statute (49 U.S.C. § 47123) (prohibits discrimination on the basis of race, color, national origin, and sex);
- (j) Executive Order 12898, Federal Actions to Address Environmental Justice in Minority Populations and Low-Income Populations, which ensures Nondiscrimination against minority populations by discouraging programs, policies, and activities with disproportionately high and adverse human health or environmental effects on minority and low-income populations;
- (k) Executive Order 13166, Improving Access to Services for Persons with Limited English Proficiency, and resulting agency guidance, national origin discrimination includes discrimination because of Limited English proficiency (LEP). To ensure compliance with Title VI, you must take reasonable steps to ensure that LEP persons have meaningful access to your programs (70 Fed. Reg. at 74087 to 74100);
- (l) Title IX of the Education Amendments of 1972, as amended, which prohibits you from discriminating because of sex in education programs or activities (20 U.S.C. 1681 et seq).
- (m) Title VII of the Civil Rights Act of 1964 (42 U.S.C. § 2000e et seq., Pub. L. 88-352), (prohibits employment discrimination on the basis of race, color, religion, sex, or national origin).

**(4) Additional Title VI Assurances**

*\*\*The following Title VI Assurances (Appendices B, C and D) shall apply, as applicable*

- (a) Clauses for Deeds Transferring United States Property (1050.2A, Appendix B)

The following clauses will be included in deeds effecting or recording the transfer of real property, structures, or improvements thereon, or granting interest therein from the United States pursuant to the provisions of Assurance 4.

NOW, THEREFORE, the U.S. Department of Transportation as authorized by law and upon the condition that the North Carolina Department of Transportation (NCDOT) will accept title to the lands and maintain the project constructed thereon in accordance with the North Carolina General Assembly, the Regulations for the Administration of the Federal-Aid Highway Program, and the policies and procedures prescribed by the Federal Highway Administration of the U.S. Department of Transportation in accordance and in compliance with all requirements imposed by Title 49, Code of Federal Regulations, U.S. Department of Transportation, Subtitle A, Office of the Secretary, Part 21, Nondiscrimination in Federally-assisted programs of the U.S. Department of Transportation pertaining to and effectuating the provisions of Title VI of the Civil Rights Act of 1964 (78 Stat. 252; 42 U.S.C. § 2000d to 2000d-4), does hereby remise, release, quitclaim and convey unto the NCDOT all the right, title and interest of the U.S. Department of Transportation in and to said lands described in Exhibit A attached hereto and made a part hereof.

(HABENDUM CLAUSE)

TO HAVE AND TO HOLD said lands and interests therein unto the North Carolina Department of Transportation (NCDOT) and its successors forever, subject, however, to the covenants, conditions, restrictions and reservations herein contained as follows, which will remain in effect for the period during which the real property or structures are used for a purpose for which Federal financial assistance is extended or for another purpose involving the provision of similar services or benefits and will be binding on the NCDOT, its successors and assigns.

The NCDOT, in consideration of the conveyance of said lands and interests in lands, does hereby covenant and agree as a covenant running with the land for itself, its successors and assigns, that (1) no person will on the grounds of race, color, or national origin, be excluded from participation in, be denied the benefits of, or be otherwise subjected to discrimination with regard to any facility located wholly or in part on, over, or under such lands hereby conveyed [,] [and]\* (2) that the NCDOT will use the lands and interests in lands and interests in lands so conveyed, in compliance with all requirements imposed by or pursuant to Title 49, Code of Federal Regulations, U.S. Department of Transportation, Subtitle A, Office of the Secretary, Part 21, Non-discrimination in Federally-assisted programs of the U.S. Department of Transportation, Effectuation of Title VI of the Civil Rights Act of 1964, and as said Regulations and Acts may be amended [, and (3) that in the event of breach of any of the above-mentioned nondiscrimination conditions, the Department will have a right to enter or re-enter said lands and facilities on said land, and that above described land and facilities will thereon revert to and vest in and become the absolute property of the U.S. Department of Transportation and its assigns as such interest existed prior to this instruction].\*

(\*Reverter clause and related language to be used only when it is determined that such a clause is necessary in order to make clear the purpose of Title VI.)

(b) Clauses for Transfer of Real Property Acquired or Improved Under the Activity, Facility, or Program (1050.2A, Appendix C)

The following clauses will be included in deeds, licenses, leases, permits, or similar instruments entered into by the North Carolina Department of Transportation (NCDOT) pursuant to the provisions of Assurance 7(a):

1. The (grantee, lessee, permittee, etc. as appropriate) for himself/herself, his/her heirs, personal representatives, successors in interest, and assigns, as a part of the consideration hereof, does hereby covenant and agree [in the case of deeds and leases add "as a covenant running with the land"] that:
  - (i.) In the event facilities are constructed, maintained, or otherwise operated on the property described in this (deed, license, lease, permit, etc.) for a purpose for which a U.S. Department of Transportation activity, facility, or program is extended or for another purpose involving the provision of similar services or benefits, the (grantee, licensee, lessee, permittee, etc.) will maintain and operate such facilities and services in compliance with all requirements imposed by the Acts and Regulations (as may be amended) such that no person on the grounds of race, color, or national origin, will be excluded from participation in, denied the benefits of, or be otherwise subjected to discrimination in the use of said facilities.
2. With respect to licenses, leases, permits, etc., in the event of breach of any of the above Nondiscrimination covenants, the NCDOT will have the right to terminate the (lease, license, permit, etc.) and to enter, re-enter, and repossess said lands and facilities thereon, and hold the same as if the (lease, license, permit, etc.) had never been made or issued. \*
3. With respect to a deed, in the event of breach of any of the above Nondiscrimination covenants, the NCDOT will have the right to enter or re-enter the lands and facilities thereon, and the above described lands and facilities will there upon revert to and vest in and become the absolute property of the NCDOT and its assigns. \*

(\*Reverter clause and related language to be used only when it is determined that such a clause is necessary to make clear the purpose of Title VI.)

(c) Clauses for Construction/Use/Access to Real Property Acquired Under the Activity, Facility or Program (1050.2A, Appendix D)

The following clauses will be included in deeds, licenses, permits, or similar instruments/ agreements entered into by the North Carolina Department of Transportation (NCDOT) pursuant to the provisions of Assurance 7(b):

1. The (grantee, licensee, permittee, etc., as appropriate) for himself/herself, his/her heirs, personal representatives, successors in interest, and assigns, as a part of the consideration hereof, does hereby covenant and agree (in the case of deeds and leases add, "as a covenant running with the land") that (1) no person on the ground of race, color, or national origin, will be excluded from participation in, denied the benefits of, or be otherwise subjected to discrimination in the use of said facilities, (2) that in the construction of any improvements on, over, or under such land, and the furnishing of services thereon, no person on the ground of race, color, or national origin, will be excluded from participation in, denied the benefits of, or otherwise be subjected to discrimination, (3) that the (grantee, licensee, lessee, permittee, etc.) will use the premises in compliance with all other requirements imposed by or pursuant to the Acts and Regulations, as amended, set forth in this Assurance.
2. With respect to (licenses, leases, permits, etc.), in the event of breach of any of the above Non-discrimination covenants, the NCDOT will have the right to terminate the (license, permit, etc., as appropriate) and to enter or re-enter and repossess said land and the facilities thereon, and hold the same as if said (license, permit, etc., as appropriate) had never been made or issued. \*
3. With respect to deeds, in the event of breach of any of the above Nondiscrimination covenants, the NCDOT will there upon revert to and vest in and become the absolute property of the NCDOT and its assigns. \*

(\*Reverter clause and related language to be used only when it is determined that such a clause is necessary to make clear the purpose of Title VI.)

**STANDARD SPECIAL PROVISION****ON-THE-JOB TRAINING**

(10-16-07) (Rev. 4-21-15)

Z-10

**Description**

The North Carolina Department of Transportation will administer a custom version of the Federal On-the-Job Training (OJT) Program, commonly referred to as the Alternate OJT Program. All contractors (existing and newcomers) will be automatically placed in the Alternate Program. Standard OJT requirements typically associated with individual projects will no longer be applied at the project level. Instead, these requirements will be applicable on an annual basis for each contractor administered by the OJT Program Manager.

On the Job Training shall meet the requirements of 23 CFR 230.107 (b), 23 USC – Section 140, this provision and the On-the-Job Training Program Manual.

The Alternate OJT Program will allow a contractor to train employees on Federal, State and privately funded projects located in North Carolina. However, priority shall be given to training employees on NCDOT Federal-Aid funded projects.

**Minorities and Women**

Developing, training and upgrading of minorities and women toward journeyman level status is a primary objective of this special training provision. Accordingly, the Contractor shall make every effort to enroll minority and women as trainees to the extent that such persons are available within a reasonable area of recruitment. This training commitment is not intended, and shall not be used, to discriminate against any applicant for training, whether a member of a minority group or not.

**Assigning Training Goals**

The Department, through the OJT Program Manager, will assign training goals for a calendar year based on the contractors' past three years' activity and the contractors' anticipated upcoming year's activity with the Department. At the beginning of each year, all contractors eligible will be contacted by the Department to determine the number of trainees that will be assigned for the upcoming calendar year. At that time the Contractor shall enter into an agreement with the Department to provide a self-imposed on-the-job training program for the calendar year. This agreement will include a specific number of annual training goals agreed to by both parties. The number of training assignments may range from 1 to 15 per contractor per calendar year. The Contractor shall sign an agreement to fulfill their annual goal for the year.\

**Training Classifications**

The Contractor shall provide on-the-job training aimed at developing full journeyman level workers in the construction craft/operator positions. Preference shall be given to providing training in the following skilled work classifications:

Equipment Operators	Office Engineers
Truck Drivers	Estimators
Carpenters	Iron / Reinforcing Steel Workers
Concrete Finishers	Mechanics
Pipe Layers	Welders

The Department has established common training classifications and their respective training requirements that may be used by the contractors. However, the classifications established are not all-inclusive. Where the training is oriented toward construction applications, training will be allowed in lower-level management positions such as office engineers and estimators. Contractors shall submit new classifications for specific job functions that their employees are performing. The Department will review and recommend for acceptance to FHWA the new classifications proposed by contractors, if applicable. New classifications shall meet the following requirements:

Proposed training classifications are reasonable and realistic based on the job skill classification needs, and

The number of training hours specified in the training classification is consistent with common practices and provides enough time for the trainee to obtain journeyman level status.

The Contractor may allow trainees to be trained by a subcontractor provided that the Contractor retains primary responsibility for meeting the training and this provision is made applicable to the subcontract. However, only the Contractor will receive credit towards the annual goal for the trainee.

Where feasible, 25 percent of apprentices or trainees in each occupation shall be in their first year of apprenticeship or training. The number of trainees shall be distributed among the work classifications on the basis of the contractor's needs and the availability of journeymen in the various classifications within a reasonable area of recruitment.

No employee shall be employed as a trainee in any classification in which they have successfully completed a training course leading to journeyman level status or in which they have been employed as a journeyman.

**Records and Reports**

The Contractor shall maintain enrollment, monthly and completion reports documenting company compliance under these contract documents. These documents and any other information as requested shall be submitted to the OJT Program Manager.

Upon completion and graduation of the program, the Contractor shall provide each trainee with a certification Certificate showing the type and length of training satisfactorily completed.

**Trainee Interviews**

All trainees enrolled in the program will receive an initial and Trainee/Post graduate interview conducted by the OJT program staff.

**Trainee Wages**

Contractors shall compensate trainees on a graduating pay scale based upon a percentage of the prevailing minimum journeyman wages (Davis-Bacon Act). Minimum pay shall be as follows:

60 percent	of the journeyman wage for the first half of the training period
75 percent	of the journeyman wage for the third quarter of the training period
90 percent	of the journeyman wage for the last quarter of the training period

In no instance shall a trainee be paid less than the local minimum wage. The Contractor shall adhere to the minimum hourly wage rate that will satisfy both the NC Department of Labor (NCDOL) and the Department.

**Achieving or Failing to Meet Training Goals**

The Contractor will be credited for each trainee employed by him on the contract work who is currently enrolled or becomes enrolled in an approved program and who receives training for at least 50 percent of the specific program requirement. Trainees will be allowed to be transferred between projects if required by the Contractor's scheduled workload to meet training goals.

If a contractor fails to attain their training assignments for the calendar year, they may be taken off the NCDOT's Bidders List.

**Measurement and Payment**

No compensation will be made for providing required training in accordance with these contract documents.



**Project Special Provisions  
Erosion Control**

**STABILIZATION REQUIREMENTS:**

(4-30-2019)

Stabilization for this project shall comply with the time frame guidelines as specified by the NCG-010000 general construction permit effective April 1, 2019 issued by the North Carolina Department of Environmental Quality Division of Water Resources. Temporary or permanent ground cover stabilization shall occur within 7 calendar days from the last land-disturbing activity, with the following exceptions in which temporary or permanent ground cover shall be provided in 14 calendar days from the last land-disturbing activity:

- Slopes between 2:1 and 3:1, with a slope length of 10 ft. or less
- Slopes 3:1 or flatter, with a slope of length of 50 ft. or less
- Slopes 4:1 or flatter

The stabilization timeframe for High Quality Water (HQW) Zones shall be 7 calendar days with no exceptions for slope grades or lengths. High Quality Water Zones (HQW) Zones are defined by North Carolina Administrative Code 15A NCAC 04A.0105 (25). Temporary and permanent ground cover stabilization shall be achieved in accordance with the provisions in this contract and as directed.

**SEEDING AND MULCHING:**

**(East)**

The kinds of seed and fertilizer, and the rates of application of seed, fertilizer, and limestone, shall be as stated below. During periods of overlapping dates, the kind of seed to be used shall be determined. All rates are in pounds per acre.

All Roadway Areas

<b>March 1 - August 31</b>		<b>September 1 - February 28</b>	
50#	Tall Fescue	50#	Tall Fescue
10#	Centipede	10#	Centipede
25#	Bermudagrass (hulled)	35#	Bermudagrass (unhulled)
500#	Fertilizer	500#	Fertilizer
4000#	Limestone	4000#	Limestone

Waste and Borrow Locations

<b>March 1 – August 31</b>		<b>September 1 - February 28</b>	
75#	Tall Fescue	75#	Tall Fescue
25#	Bermudagrass (hulled)	35#	Bermudagrass (unhulled)
500#	Fertilizer	500#	Fertilizer
4000#	Limestone	4000#	Limestone

Note: 50# of Bahiagrass may be substituted for either Centipede or Bermudagrass only upon Engineer's request.

#### Approved Tall Fescue Cultivars

06 Dust	Escalade	Justice	Serengeti
2 <sup>nd</sup> Millennium	Essential	Kalahari	Shelby
3 <sup>rd</sup> Millennium	Evergreen 2	Kitty Hawk 2000	Sheridan
Apache III	Falcon IV	Legitimate	Signia
Avenger	Falcon NG	Lexington	Silver Hawk
Barlexas	Falcon V	LSD	Sliverstar
Barlexas II	Faith	Magellan	Shenandoah Elite
Bar Fa	Fat Cat	Matador	Sidewinder
Barrera	Festnova	Millennium SRP	Skyline
Barrington	Fidelity	Monet	Solara
Barrobusto	Finelawn Elite	Mustang 4	Southern Choice II
Barvado	Finelawn Xpress	Ninja 2	Speedway
Biltmore	Finesse II	Ol' Glory	Spyder LS
Bingo	Firebird	Olympic Gold	Sunset Gold
Bizem	Firecracker LS	Padre	Taccoa
Blackwatch	Firenza	Patagonia	Tanzania
Blade Runner II	Five Point	Pedigree	Trio
Bonsai	Focus	Picasso	Tahoe II
Braveheart	Forte	Piedmont	Talladega
Bravo	Garrison	Plantation	Tarheel
Bullseye	Gazelle II	Proseeds 5301	Terrano
Cannavaro	Gold Medallion	Prospect	Titan ltd
Catalyst	Grande 3	Pure Gold	Titanium LS
Cayenne	Greenbrooks	Quest	Tracer
Cessane Rz	Greenkeeper	Raptor II	Traverse SRP
Chipper	Gremlin	Rebel Exeda	Tulsa Time
Cochise IV	Greystone	Rebel Sentry	Turbo
Constitution	Guardian 21	Rebel IV	Turbo RZ
Corgi	Guardian 41	Regiment II	Tuxedo RZ
Corona	Hemi	Regenerate	Ultimate
Coyote	Honky Tonk	Rendition	Venture
Darlington	Hot Rod	Rhambler 2 SRP	Umbrella
Davinci	Hunter	Rembrandt	Van Gogh
Desire	Inferno	Reunion	Watchdog
Dominion	Innovator	Riverside	Wolfpack II
Dynamic	Integrity	RNP	Xtremegreen
Dynasty	Jaguar 3	Rocket	
Endeavor	Jamboree	Scorpion	

On cut and fill slopes 2:1 or steeper Centipede shall be applied at the rate of 5 pounds per acre and add 20# of Sericea Lespedeza from January 1 - December 31.

Fertilizer shall be 10-20-20 analysis. A different analysis of fertilizer may be used provided the 1-2-2 ratio is maintained and the rate of application adjusted to provide the same amount of plant food as a 10-20-20 analysis and as directed.

**Native Grass Seeding and Mulching (East)**

Native Grass Seeding and Mulching shall be performed on the disturbed areas of wetlands and riparian areas, and adjacent to Stream Relocation construction within a 50 foot zone on both sides of the stream or depression, measured from top of stream bank or center of depression. The stream bank of the stream relocation shall be seeded by a method that does not alter the typical cross section of the stream bank. Native Grass Seeding and Mulching shall also be performed in the permanent soil reinforcement mat section of preformed scour holes, and in other areas as directed.

The kinds of seed and fertilizer, and the rates of application of seed, fertilizer, and limestone, shall be as stated below. During periods of overlapping dates, the kind of seed to be used shall be determined. All rates are in pounds per acre.

<b>March 1 - August 31</b>		<b>September 1 - February 28</b>	
18#	Creeping Red Fescue	18#	Creeping Red Fescue
6#	Indiangrass	6#	Indiangrass
8#	Little Bluestem	8#	Little Bluestem
4#	Switchgrass	4#	Switchgrass
25#	Browntop Millet	35#	Rye Grain
500#	Fertilizer	500#	Fertilizer
4000#	Limestone	4000#	Limestone

Approved Creeping Red Fescue Cultivars:

- |          |        |      |           |
|----------|--------|------|-----------|
| Aberdeen | Boreal | Epic | Cindy Lou |
|----------|--------|------|-----------|

Fertilizer shall be 10-20-20 analysis. A different analysis of fertilizer may be used provided the 1-2-2 ratio is maintained and the rate of application adjusted to provide the same amount of plant food as a 10-20-20 analysis and as directed.

Native Grass Seeding and Mulching shall be performed in accordance with Section 1660 of the *Standard Specifications* and vegetative cover sufficient to restrain erosion shall be installed immediately following grade establishment.

**Measurement and Payment**

Native Grass *Seeding and Mulching* will be measured and paid for in accordance with Article 1660-8 of the *Standard Specifications*.

All areas seeded and mulched shall be tacked with asphalt. Crimping of straw in lieu of asphalt tack shall not be allowed on this project.

**CRIMPING STRAW MULCH:**

Crimping shall be required on this project adjacent to any section of roadway where traffic is to be maintained or allowed during construction. In areas within six feet of the edge of pavement, straw is to be applied and then crimped. After the crimping operation is complete, an additional application of straw shall be applied and immediately tacked with a sufficient amount of undiluted emulsified asphalt.

Straw mulch shall be of sufficient length and quality to withstand the crimping operation.

Crimping equipment including power source shall be subject to the approval of the Engineer providing that maximum spacing of crimper blades shall not exceed 8".

**TEMPORARY SEEDING:**

Fertilizer shall be the same analysis as specified for *Seeding and Mulching* and applied at the rate of 400 pounds and seeded at the rate of 50 pounds per acre. Sweet Sudan Grass, German Millet or Browntop Millet shall be used in summer months and Rye Grain during the remainder of the year. The Engineer will determine the exact dates for using each kind of seed.

**FERTILIZER TOPDRESSING:**

Fertilizer used for topdressing on all roadway areas except slopes 2:1 and steeper shall be 10-20-20 grade and shall be applied at the rate of 500 pounds per acre. A different analysis of fertilizer may be used provided the 1-2-2 ratio is maintained and the rate of application adjusted to provide the same amount of plant food as 10-20-20 analysis and as directed.

Fertilizer used for topdressing on slopes 2:1 and steeper and waste and borrow areas shall be 16-8-8 grade and shall be applied at the rate of 500 pounds per acre. A different analysis of fertilizer may be used provided the 2-1-1 ratio is maintained and the rate of application adjusted to provide the same amount of plant food as 16-8-8 analysis and as directed.

**SUPPLEMENTAL SEEDING:**

The kinds of seed and proportions shall be the same as specified for *Seeding and Mulching*, with the exception that no centipede seed will be used in the seed mix for supplemental seeding. The rate of application for supplemental seeding may vary from 25# to 75# per acre. The actual rate per acre will be determined prior to the time of topdressing and the Contractor will be notified in writing of the rate per acre, total quantity needed, and areas on which to apply the supplemental seed. Minimum tillage equipment, consisting of a sod seeder shall be used for incorporating seed into the soil as to prevent disturbance of existing vegetation. A clodbuster (ball and chain) may be used where degree of slope prevents the use of a sod seeder.

**Project Special Provisions  
Structures  
Table of Contents**

<b>Special Provision</b>		<b>Page</b>
Scope of Work		BP-2
Falsework and Formwork	(11-30-23)	BP-2
Submittal of Working Drawings	(11-30-23)	BP-8
Crane Safety	(06-20-19)	BP-14
Grout for Structures	(12-01-17)	BP-15
Securing of Vessels	(10-12-01)	BP-16
LMC Overlay Surface Preparation	(11-30-23)	BP-16
Latex Modified Concrete Overlay–Very Early Strength	(11-30-23)	BP-24
Overlay Surface Preparation for Polymer Concrete	(08-08-22)	BP-28
Polymer Concrete Bridge Deck Overlay	(08-08-22)	BP-35
Volumetric Mixer	(11-30-23)	BP-48
Bridge Joint Demolition	(11-30-23)	BP-50
Foam Joint Seal for Preservation	(11-30-23)	BP-51
Elastomeric Concrete for Preservation	(02-11-19)	BP-55
Concrete Repairs	(11-30-23)	BP-57
Shotcrete Repairs	(11-30-23)	BP-60
Epoxy Resin Injection	(11-30-23)	BP-64
Drift Removal	(SPECIAL)	BP-69
Zone Painting of Existing Structure	(SPECIAL)	BP-70
Repairs for Prestressed Concrete Girders	(SPECIAL)	BP-85
Silane Barrier Rail Treatment	(SPECIAL)	BP-90
Epoxy Coating and Debris Removal	(SPECIAL)	BP-95
Cleaning and Painting Existing Bearings with HRCSA	(SPECIAL)	BP-96
Bridge Jacking	(SPECIAL)	BP-113

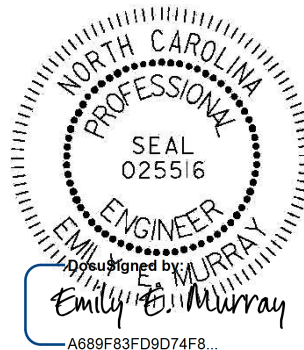

5/13/2024

**SCOPE OF WORK**

This work shall consist of furnishing all labor, equipment, and materials to perform bridge deck surface preparation and deck overlays with polymer concrete (Bridges 180007 and 180477) or latex modified concrete (Bridges 620049 and 620072), as well as repairs to superstructure and substructure as directed in the plans and special provisions. Work includes: portable lighting, existing bridge deck surface preparation by scarification and shotblasting for polymer concrete overlay; overlaying the prepared bridge decks with polymer concrete; existing bridge deck surface preparation by scarification and hydro-demolition for latex modified concrete overlay; overlaying the prepared bridge decks with latex modified concrete-very early strength; perform deck repairs; installation of foam joint seals with elastomeric headers; grooving bridge deck; prestressed concrete girder repairs; cleaning and zone painting of existing structures, cleaning and painting existing bearings with HRCSA, substructure repair using concrete, shotcrete, and epoxy resin injection; drift removal; disposal of demolition and waste material; and all incidental items necessary to complete the project as specified and shown on the plans. No separate measurement or payment will be made for seeding, mulching or any measures required to control erosion or prevent off-site sedimentation. The cost of this work shall be included in the lump sum price bid for Mobilization.

Work will be performed on the existing bridges in Chatham and Moore Counties at the following locations:

- 1) Bridge #180007 on US 1 SBL over Deep River
- 2) Bridge #180477 on US 1 SBL over Deep River
- 3) Bridge #620049 on SR 1626 over Deep River
- 4) Bridge #620072 on NC 22 over Deep River

Contractor shall provide all necessary access; provide all traffic control; provide all staging areas; material storage; waste disposal; provide environmental controls to limit loss of materials from collection of sawing equipment and chipping equipment; and all else necessary to complete the work.

The contractor shall be responsible for fulfilling all requirements of the NCDOT Standard Specifications for Roads and Structures dated January 2024, except as otherwise specified herein.

**FALSEWORK AND FORMWORK****(11-30-23)****GENERAL**

Use this Special Provision as a guide to develop temporary works submittals required by the *Standard Specifications* or other provisions; no additional submittals are required herein. Such temporary works include, but are not limited to, falsework and formwork.

Falsework is any temporary construction used to support the permanent structure until it becomes self-supporting. Formwork is the temporary structure or mold used to retain plastic or fluid concrete in its designated shape until it hardens. Access scaffolding is a temporary structure that functions as a work platform that supports construction personnel, materials, and tools, but is not intended to support the structure. Scaffolding systems that are used to temporarily support

permanent structures (as opposed to functioning as work platforms) are considered to be falsework under the definitions given. Shoring is a component of falsework such as horizontal, vertical, or inclined support members. Where the term “temporary works” is used, it includes all of the temporary facilities used in bridge construction that do not become part of the permanent structure.

Design and construct safe and adequate temporary works that will support all loads imposed and provide the necessary rigidity to achieve the lines and grades shown on the plans in the final structure.

### **MATERIALS**

Select materials suitable for temporary works; however, select materials that also ensure the safety and quality required by the design assumptions. The Engineer has authority to reject material on the basis of its condition, inappropriate use, safety, or nonconformance with the plans. Clearly identify allowable loads or stresses for all materials or manufactured devices on the plans. Revise the plan and notify the Engineer if any change to materials or material strengths is required.

### **DESIGN REQUIREMENTS**

#### **(A) Working Drawings**

Provide working drawings for items as specified in the contract, or as required by the Engineer, with design calculations and supporting data in sufficient detail to permit a structural and safety review of the proposed design of the temporary work.

On the drawings, show all information necessary to allow the design of any component to be checked independently as determined by the Engineer.

When concrete placement is involved, include data such as the drawings of proposed sequence, rate of placement, direction of placement, and location of all construction joints.

When required, have the drawings and calculations prepared under the guidance of, and sealed by, a North Carolina Registered Professional Engineer who is knowledgeable in temporary works design.

If requested by the Engineer, submit with the working drawings manufacturer’s catalog data listing the weight of all construction equipment that will be supported on the temporary work. Show anticipated total settlements and/or deflections of falsework and forms on the working drawings. Include falsework footing settlements, joint take-up, and deflection of beams or girders.

As an option for the Contractor, overhang falsework hangers may be uniformly spaced, at a maximum of 36 inches, provided the following conditions are met:

Member Type (PCG)	Member Depth, (inches)	Max. Overhang Width, (inches)	Max. Slab Edge Thickness, (inches)	Max. Screenshot Wheel Weight, (lbs.)	Bracket Min. Vertical Leg Extension, (inches)
II	36	39	14	2000	26
III	45	42	14	2000	35
IV	54	45	14	2000	44
MBT	63	51	12	2000	50

MBT	72	55	12	1700	48
-----	----	----	----	------	----

Overhang width is measured from the centerline of the girder to the edge of the deck slab. For Type II, III & IV prestressed concrete girders (PCG), 45-degree cast-in-place half hangers and rods must have a minimum safe working load of 6,000 lbs.

For MBT prestressed concrete girders, 45-degree angle holes for falsework hanger rods shall be cast through the girder top flange and located, measuring along the top of the member, 1'-2 1/2" from the edge of the top flange. Hanger hardware and rods must have a minimum safe working load of 6,000 lbs.

For link slabs, the top of girders directly beneath the link slab shall be free of overhang falsework attachments or other hardware. Submit calculations and working drawings for overhang falsework in the link slab region.

The overhang bracket provided for the diagonal leg shall have a minimum safe working load of 3,750 lbs. The vertical leg of the bracket shall extend to the point that the heel bears on the girder bottom flange, no closer than 4 inches from the bottom of the member. However, for 72-inch members, the heel of the bracket shall bear on the web, near the bottom flange transition.

Provide adequate overhang falsework and determine the appropriate adjustments for deck geometry, equipment, casting procedures and casting conditions.

If the optional overhang falsework spacing is used, indicate this on the falsework submittal and advise the girder producer of the proposed details. Failure to notify the Engineer of hanger type and hanger spacing on prestressed concrete girder casting drawings may delay the approval of those drawings.

Falsework hangers that support concentrated loads and are installed at the edge of thin top flange concrete girders (such as bulb tee girders) shall be spaced so as not to exceed 75% of the manufacturer's stated safe working load. Use of dual leg hangers (such as Meadow Burke HF-42 and HF-43) are not allowed on concrete girders with thin top flanges. Design the falsework and forms supporting deck slabs and overhangs on girder bridges so that there will be no differential settlement between the girders and the deck forms during placement of deck concrete.

When staged construction of the bridge deck is required, detail falsework and forms for screed and fluid concrete loads to be independent of any previous deck pour components when the mid-span girder deflection due to deck weight is greater than 3/4".

Note on the working drawings any anchorages, connectors, inserts, steel sleeves or other such devices used as part of the falsework or formwork that remains in the permanent structure. If the plan notes indicate that the structure contains the necessary corrosion protection required for a Corrosive Site, epoxy coat, galvanize or metalize these devices. Electroplating will not be allowed. Any coating required by the Engineer will be considered incidental to the various pay items requiring temporary works.



Design falsework and formwork requiring submittals in accordance with the current edition of *AASHTO Guide Design Specifications for Bridge Temporary Works* except as noted herein.

(1) Wind Loads

Table 2.2 of Article 2.2.5.1 is modified to include wind velocities up to 110 mph. In addition, Table 2.2A is included to provide the maximum wind speeds by county in North Carolina.

**Table 2.2 - Wind Pressure Values**

Height Zone feet above ground	Pressure, lb/ft <sup>2</sup> for Indicated Wind Velocity, mph				
	70	80	90	100	110
0 to 30	15	20	25	30	35
30 to 50	20	25	30	35	40
50 to 100	25	30	35	40	45
over 100	30	35	40	45	50

(2) Time of Removal

The following requirements replace those of Article 3.4.8.2.

Do not remove forms until the concrete has attained strengths required in Article 420-16 of the *Standard Specifications* and these Special Provisions.

Do not remove forms until the concrete has sufficient strength to prevent surface damage.

**Table 2.2A - Steady State Maximum Wind Speeds by Counties in North Carolina**

COUNTY	25 YR (mph)	COUNTY	25 YR (mph)	COUNTY	25 YR (mph)
Alamance	70	Franklin	70	Pamlico	100
Alexander	70	Gaston	70	Pasquotank	100
Alleghany	70	Gates	90	Pender	100
Anson	70	Graham	80	Perquimans	100
Ashe	70	Granville	70	Person	70
Avery	70	Greene	80	Pitt	90
Beaufort	100	Guilford	70	Polk	80
Bertie	90	Halifax	80	Randolph	70
Bladen	90	Harnett	70	Richmond	70
Brunswick	100	Haywood	80	Robeson	80
Buncombe	80	Henderson	80	Rockingham	70
Burke	70	Hertford	90	Rowan	70
Cabarrus	70	Hoke	70	Rutherford	70
Caldwell	70	Hyde	110	Sampson	90
Camden	100	Iredell	70	Scotland	70
Carteret	110	Jackson	80	Stanley	70
Caswell	70	Johnston	80	Stokes	70
Catawba	70	Jones	100	Surry	70
Cherokee	80	Lee	70	Swain	80
Chatham	70	Lenoir	90	Transylvania	80
Chowan	90	Lincoln	70	Tyrell	100
Clay	80	Macon	80	Union	70
Cleveland	70	Madison	80	Vance	70
Columbus	90	Martin	90	Wake	70
Craven	100	McDowell	70	Warren	70
Cumberland	80	Mecklenburg	70	Washington	100
Currituck	100	Mitchell	70	Watauga	70
Dare	110	Montgomery	70	Wayne	80
Davidson	70	Moore	70	Wilkes	70
Davie	70	Nash	80	Wilson	80
Duplin	90	New Hanover	100	Yadkin	70
Durham	70	Northampton	80	Yancey	70
Edgecombe	80	Onslow	100		
Forsyth	70	Orange	70		

**(B) Review and Approval**

The Engineer is responsible for the review and approval of temporary works' drawings.

Submit the working drawings sufficiently in advance of proposed use to allow for their review, revision (if needed), and approval without delay to the work.

The time period for review of the working drawings does not begin until complete drawings and design calculations, when required, are received by the Engineer.

Do not start construction of any temporary work for which working drawings are required until the drawings have been approved. Such approval does not relieve the Contractor of the responsibility for the accuracy and adequacy of the working drawings.

**CONSTRUCTION REQUIREMENTS**

All requirements of Section 420 of the *Standard Specifications* apply.

Construct temporary works in conformance with the approved working drawings. Ensure that the quality of materials and workmanship employed is consistent with that assumed in the design of the temporary works. Do not weld falsework members to any portion of the permanent structure unless approved. Show any welding to the permanent structure on the approved construction drawings.

Provide tell-tales attached to the forms and extending to the ground, or other means, for accurate measurement of falsework settlement. Make sure that the anticipated compressive settlement and/or deflection of falsework does not exceed 1 inch. For cast-in-place concrete structures, make sure that the calculated deflection of falsework flexural members does not exceed 1/240 of their span regardless of whether or not the deflection is compensated by camber strips.

**(A) Maintenance and Inspection**

Inspect and maintain the temporary work in an acceptable condition throughout the period of its use. Certify that the manufactured devices have been maintained in a condition to allow them to safely carry their rated loads. Clearly mark each piece so that its capacity can be readily determined at the job site.

Perform an in-depth inspection of an applicable portion(s) of the temporary works, in the presence of the Engineer, not more than 24 hours prior to the beginning of each concrete placement. Inspect other temporary works at least once a month to ensure that they are functioning properly. Have a North Carolina Registered Professional Engineer inspect the cofferdams, shoring, sheathing, support of excavation structures, and support systems for load tests prior to loading.

**(B) Foundations**

Determine the safe bearing capacity of the foundation material on which the supports for temporary works rest. If required by the Engineer, conduct load tests to verify proposed bearing capacity values that are marginal or in other high-risk situations.

The use of the foundation support values shown on the contract plans of the permanent structure is permitted if the foundations are on the same level and on the same soil as those of the permanent structure.

Allow for adequate site drainage or soil protection to prevent soil saturation and washout of the soil supporting the temporary works supports.

If piles are used, the estimation of capacities and later confirmation during construction using standard procedures based on the driving characteristics of the pile is permitted. If preferred, use load tests to confirm the estimated capacities; or, if required by the Engineer conduct load tests to verify bearing capacity values that are marginal or in other high risk situations.

The Engineer reviews and approves the proposed pile and soil bearing capacities.

**REMOVAL**

Unless otherwise permitted, remove and keep all temporary works upon completion of the work. Do not disturb or otherwise damage the finished work.

Remove temporary works in conformance with the contract documents. Remove them in such a manner as to permit the structure to uniformly and gradually take the stresses due to its own weight.

**MEASUREMENT AND PAYMENT**

Unless otherwise specified, *Falsework and Formwork* will not be directly measured.

Payment at the contract unit prices for the various pay items requiring temporary works will be full compensation for the above falsework and formwork.

**SUBMITTAL OF WORKING DRAWINGS****(11-30-23)****GENERAL**

Submit working drawings in accordance with Article 105-2 of the *Standard Specifications* and this Special Provision. For this Special Provision, “submittals” refers to only those listed in this Special Provision. The list of submittals contained herein does not represent a list of required submittals for the project. Submittals are only necessary for those items as required by the contract. Make submittals that are not specifically noted in this provision directly to the Engineer. Either the Structures Management Unit or the Geotechnical Engineering Unit or both units will jointly review submittals.

15BPR.130.3

**BP-9**

Chatham and Moore Counties

If a submittal contains variations from plan details or specifications or significantly affects project cost, field construction or operations, discuss the submittal with and submit all copies to the Engineer. State the reason for the proposed variation in the submittal. To minimize review time, make sure all submittals are complete when initially submitted. Provide a contact name and information with each submittal. Direct any questions regarding submittal requirements to the Engineer, Structures Management Unit contacts or the Geotechnical Engineering Unit contacts noted below.

To facilitate in-plant inspection by NCDOT and approval of working drawings, provide the name, address and telephone number of the facility where fabrication will actually be done if different than shown on the title block of the submitted working drawings. This includes, but is not limited to, precast concrete items, prestressed concrete items and fabricated steel or aluminum items.

**ADDRESSES AND CONTACTS**

For submittals to the Structures Management Unit, use the following addresses:

Via Email: [SMU-wdr@ncdot.gov](mailto:SMU-wdr@ncdot.gov) (do not cc SMU Working Drawings staff)

Via US mail:

Mr. B. C. Hanks, P. E.  
State Structures Engineer  
North Carolina Department  
of Transportation  
Structures Management Unit  
1581 Mail Service Center  
Raleigh, NC 27699-1581

Attention: Mr. J. L. Bolden, P. E.

Via other delivery service:

Mr. B. C. Hanks, P. E.  
State Structures Engineer  
North Carolina Department  
of Transportation  
Structures Management Unit  
1000 Birch Ridge Drive  
Raleigh, NC 27610

Attention: Mr. J. L. Bolden, P. E.

For submittals to the Geotechnical Engineering Unit, use the following addresses:

For projects in Divisions 1-7, use the following Eastern Regional Office addresses:

Via Email: [EastGeotechnicalSubmittal@ncdot.gov](mailto:EastGeotechnicalSubmittal@ncdot.gov)

Via US mail:

Mr. Thomas Santee, P. E.  
Assistant State Geotechnical  
Engineer – Eastern Region  
North Carolina Department  
of Transportation  
Geotechnical Engineering Unit  
Eastern Regional Office  
1570 Mail Service Center  
Raleigh, NC 27699-1570

Via other delivery service:

Mr. Thomas Santee, P. E.  
Assistant State Geotechnical  
Engineer – Eastern Region  
North Carolina Department  
of Transportation  
Geotechnical Engineering Unit  
Eastern Regional Office  
3301 Jones Sausage Road, Suite 100  
Garner, NC 27529

15BPR.130.3

**BP-10**

Chatham and Moore Counties

For projects in Divisions 8-14, use the following Western Regional Office addresses:

Via Email: [WestGeotechnicalSubmittal@ncdot.gov](mailto:WestGeotechnicalSubmittal@ncdot.gov)

Via US mail or other delivery service:

Mr. Eric Williams, P. E.  
Assistant State Geotechnical  
Engineer – Western Region  
North Carolina Department  
of Transportation  
Geotechnical Engineering Unit  
Western Regional Office  
5253 Z Max Boulevard  
Harrisburg, NC 28075

The status of the review of structure-related submittals sent to the Structures Management Unit can be viewed from the Unit’s website, via the “[Drawing Submittal Status](#)” link.

The status of the review of geotechnical-related submittals sent to the Geotechnical Engineering Unit can be viewed from the Unit’s website, via the “[Geotechnical Construction Submittals](#)” link.

Direct any questions concerning submittal review status, review comments or drawing markups to the following contacts:

Primary Structures Contact: James Bolden (919) 707 – 6408  
[jlbolden@ncdot.gov](mailto:jlbolden@ncdot.gov)

Secondary Structures Contacts: Emmanuel Omile (919) 707 – 6451  
[eomile@ncdot.gov](mailto:eomile@ncdot.gov)

Madonna Rorie (919) 707 – 6508  
[mrorie@ncdot.gov](mailto:mrorie@ncdot.gov)

Eastern Regional Geotechnical Contact (Divisions 1-7):  
Thomas Santee (919) 920-8901  
[tgsantee@ncdot.gov](mailto:tgsantee@ncdot.gov)

Western Regional Geotechnical Contact (Divisions 8-14):  
Eric Williams (704) 455 – 8902  
[ewilliams3@ncdot.gov](mailto:ewilliams3@ncdot.gov)

**SUBMITTAL COPIES**

Furnish one complete copy of each submittal, including all attachments, to the Engineer. At the same time, submit a copy of the same complete submittal directly to the Structures Management Unit and/or the Geotechnical Engineering Unit as specified in the tables below.

The first table below covers “Structure Submittals.” The Engineer will receive review comments and drawing markups for these submittals from the Structures Management Unit. The second table in this section covers “Geotechnical Submittals.” The Engineer will receive review comments and drawing markups for these submittals from the Geotechnical Engineering Unit.

Unless otherwise required, submit one set of supporting calculations to either the Structures Management Unit or the Geotechnical Engineering Unit unless both units require submittal copies in which case submit a set of supporting calculations to each unit. Provide additional copies of any submittal as directed.

**STRUCTURE SUBMITTALS**

<b>Submittal</b>	<b>Submittal Required by Structures Management Unit?</b>	<b>Submittal Required by Geotechnical Engineering Unit?</b>	<b>Contract Reference Requiring Submittal <sup>1</sup></b>
Arch Culvert Falsework	Y	N	Plan Note, SN Sheet & “Falsework and Formwork”
Box Culvert Falsework <sup>7</sup>	Y	N	Plan Note, SN Sheet & “Falsework and Formwork”
Cofferdams	Y	Y	Article 410-4
Foam Joint Seals <sup>6</sup>	Y	N	“Foam Joint Seals”
Expansion Joint Seals (hold down plate type with base angle)	Y	N	“Expansion Joint Seals”
Expansion Joint Seals (modular)	Y	N	“Modular Expansion Joint Seals”
Expansion Joint Seals (strip seals)	Y	N	“Strip Seal Expansion Joints”
Falsework & Forms <sup>2</sup> (substructure)	Y	N	Article 420-3 & “Falsework and Formwork”
Falsework & Forms (superstructure)	Y	N	Article 420-3 & “Falsework and Formwork”
Girder Erection over Railroad	Y	N	Railroad Provisions
Maintenance and Protection of Traffic Beneath Proposed Structure	Y	N	“Maintenance and Protection of Traffic Beneath Proposed Structure at Station ____”

15BPR.130.3

**BP-12**

Chatham and Moore Counties

Metal Bridge Railing	Y	N	Plan Note
Metal Stay-in-Place Forms	Y	N	Article 420-3
Metalwork for Elastomeric Bearings <sup>4,5</sup>	Y	N	Article 1072-8
Miscellaneous Metalwork <sup>4,5</sup>	Y	N	Article 1072-8
Disc Bearings <sup>4</sup>	Y	N	“Disc Bearings”
Overhead and Digital Message Signs (DMS) (metalwork and foundations)	Y	N	Applicable Provisions
Placement of Equipment on Structures (cranes, etc.)	Y	N	Article 420-20
Prestressed Concrete Box Beam (detensioning sequences) <sup>3</sup>	Y	N	Article 1078-11
Precast Concrete Box Culverts	Y	N	“Optional Precast Reinforced Concrete Box Culvert at Station ____”
Prestressed Concrete Cored Slab (detensioning sequences) <sup>3</sup>	Y	N	Article 1078-11
Prestressed Concrete Deck Panels	Y	N	Article 420-3
Prestressed Concrete Girder (strand elongation and detensioning sequences)	Y	N	Articles 1078-8 and 1078-11
Removal of Existing Structure over Railroad	Y	N	Railroad Provisions
<hr/>			
Revised Bridge Deck Plans (adaptation to prestressed deck panels)	Y	N	Article 420-3
Revised Bridge Deck Plans (adaptation to modular expansion joint seals)	Y	N	“Modular Expansion Joint Seals”
Sound Barrier Wall (precast items)	Y	N	Article 1077-2 & “Sound Barrier Wall”
Sound Barrier Wall Steel Fabrication Plans <sup>5</sup>	Y	N	Article 1072-8 & “Sound Barrier Wall”
Structural Steel <sup>4</sup>	Y	N	Article 1072-8



15BPR.130.3

**BP-13**

Chatham and Moore Counties

Temporary Detour Structures	Y	Y	Article 400-3 & “Construction, Maintenance and Removal of Temporary Structure at Station _____”
TFE Expansion Bearings <sup>4</sup>	Y	N	Article 1072-8

**FOOTNOTES**

- References are provided to help locate the part of the contract where the submittals are required. References in quotes refer to the provision by that name. Articles refer to the *Standard Specifications*.
- Submittals for these items are necessary only when required by a note on plans.
- Submittals for these items may not be required. A list of pre-approved sequences is available from the producer or the Materials & Tests Unit.
- The fabricator may submit these items directly to the Structures Management Unit.
- The two sets of preliminary submittals required by Article 1072-8 of the *Standard Specifications* are not required for these items.
- Submittals for Fabrication Drawings are not required. Submittals for Catalogue Cuts of Proposed Material are required. See Section 5.A of the referenced provision.
- Submittals are necessary only when the top slab thickness is 18” or greater.

**GEOTECHNICAL SUBMITTALS**

<b>Submittal</b>	<b>Submittals Required by Geotechnical Engineering Unit</b>	<b>Submittals Required by Structures Management Unit</b>	<b>Contract Reference Requiring Submittal <sup>1</sup></b>
Drilled Pier Construction Plans <sup>2</sup>	Y	N	Subarticle 411-3(A)
Crosshole Sonic Logging (CSL) Reports <sup>2</sup>	Y	N	Subarticle 411-5(A)(2)
Pile Driving Equipment Data Forms <sup>2,3</sup>	Y	N	Subarticle 450-3(D)(2)
Pile Driving Analyzer (PDA) Reports <sup>2</sup>	Y	N	Subarticle 450-3(F)(3)

15BPR.130.3

**BP-14**

Chatham and Moore Counties

Retaining Walls <sup>4</sup>	Y; drawings and calculations	Y; drawings	Applicable Provisions
Temporary Shoring <sup>4</sup>	Y; drawings and calculations	Y; drawings	“Temporary Shoring” & “Temporary Soil Nail Walls”

**FOOTNOTES**

1. References are provided to help locate the part of the contract where the submittals are required. References in quotes refer to the provision by that name. Subarticles refer to the *Standard Specifications*.
2. Submit one hard copy of submittal to the Engineer. Submit a second copy of submittal electronically (PDF via email), US mail or other delivery service to the appropriate Geotechnical Engineering Unit regional office. Electronic submission is preferred.
3. The Pile Driving Equipment Data Form is available from:  
<https://connect.ncdot.gov/projects/construction/ConstManRefDocs/PILE%20DRIVING%20EQUIPMENT%20DATA%20FORM.pdf>  
See second page of form for submittal instructions.
4. Electronic copy of submittal is required. See referenced provision.

**CRANE SAFETY****(06-20-19)****GENERAL**

Comply with the manufacturer specifications and limitations applicable to the operation of any and all cranes and derricks. Prime contractors, sub-contractors, and fully operated rental companies shall comply with the current Occupational Safety and Health Administration (OSHA) regulations.

Submit all items listed below to the Engineer prior to beginning crane operations. Changes in personnel or equipment must be reported to the Engineer and all applicable items listed below must be updated and submitted prior to continuing with crane operations.

**CRANE SAFETY SUBMITTAL LIST**

- (A) **Competent Person:** Provide the name and qualifications of the “Competent Person” responsible for crane safety and lifting operations. The named competent person will have the responsibility and authority to stop any work activity due to safety concerns.
- (B) **Riggers:** Provide the qualifications and experience of the persons responsible for rigging operations. Qualifications and experience should include, but not be limited to, weight calculations, center of gravity determinations, selection and inspection of sling and rigging equipment, and safe rigging practices.
- (C) **Crane Inspections:** Inspection records for all cranes shall be current and readily accessible for review upon request.
- (D) **Certifications:** Crane operators shall be certified by the National Commission for the Certification of Crane Operators (NCCCO) or the National Center for Construction Education and Research (NCCER). Other approved nationally accredited programs will be considered upon request. In addition, crane operators shall have a current CDL medical card. Submit a list of crane operator(s) and include current certification for each type of crane operated (small hydraulic, large hydraulic, small lattice, large lattice) and medical evaluations for each operator.

**MEASUREMENT AND PAYMENT**

No direct payment will be made for *Crane Safety*. All costs shall be considered incidental to items for which direct payment is made.

**GROUT FOR STRUCTURES****(12-1-17)****DESCRIPTION**

This special provision addresses grout for use in pile blockouts, grout pockets, shear keys, dowel holes and recesses for structures. This provision does not apply to grout placed in post-tensioning ducts for bridge beams, girders, decks, end bent caps, or bent caps. Mix and place grout in accordance with the manufacturer’s recommendations, the applicable sections of the Standard Specifications and this provision.

**MATERIAL REQUIREMENTS**

Unless otherwise noted on the plans, use a Type 3 Grout in accordance with Section 1003 of the Standard Specifications.

Initial setting time shall not be less than 10 minutes when tested in accordance with ASTM C266.

Construction loading and traffic loading shall not be allowed until the 3 day compressive strength is achieved.

**SAMPLING AND PLACEMENT**

Place and maintain components in final position until grout placement is complete and accepted. Concrete surfaces to receive grout shall be free of defective concrete, laitance, oil, grease and other foreign matter. Saturate concrete surfaces with clean water and remove excess water prior to placing grout.

**BASIS OF PAYMENT**

No separate payment will be made for “Grout for Structures”. The cost of the material, equipment, labor, placement, and any incidentals necessary to complete the work shall be considered incidental to the structure item requiring grout.

**SECURING OF VESSELS****(10-12-01)****GENERAL**

Secure vessels in accordance with Section 107 of the *Standard Specifications* and the following provision.

When utilizing barges, tugboats or other vessels, take all necessary precautions to ensure that such vessels are securely anchored or moored when not in active operation. Take all necessary measures to ensure that the vessels are operated in a manner that avoids damage to or unnecessary contact with bridges and other highway structures and attachments. If severe weather conditions are anticipated or should be anticipated through reasonable monitoring of weather forecasts, take additional measures to protect bridges and other highway structures and attachments from extreme conditions. The Contractor is strictly liable for damages to any bridge or other highway structures or attachments caused by a vessel owned or controlled by the Contractor. The Contractor is also liable to third parties for property damages and loss of revenue caused by vessels under the Contractor’s control.

**MEASUREMENT AND PAYMENT**

No separate payment will be made for *Securing of Vessels*.

24

**LMC OVERLAY SURFACE PREPARATION****(11-30-23)****GENERAL**

This Special Provision addresses the surface preparation activities required prior to the placement of latex modified concrete. Unless specifically mentioned below, all requirements specified for the bridge deck are also required for the approach slabs.

**DEFINITIONS**

Scarification shall consist of the removal of any asphalt wearing surface and concrete surface to a uniform depth within ½” of the plan overlay thickness or to the limits shown on the plans.

Hydro-demolition shall consist of the removal of the deck surface by means of high pressure water blasting which will remove concrete, oil, dirt, concrete laitance and rust from the exposed reinforcing bars by direct impact, pressurization of micro and macro cracks and cavitation produced by jet instability.

**EQUIPMENT**

Use the following surface preparation equipment:

- (A) Scarifying equipment that is a power-operated, mechanical grinder capable of removing a minimum depth of ¼” for each pass.
- (B) Hydro-demolition machine, self-propelled with a minimum orifice pressure of 17,000 psi.
- (C) All water used for hydro-demolition shall be potable.
- (D) Equipment capable of sawing concrete to the specified plan depth.
- (E) Hand-held high velocity (7,500 psi minimum) water-jet equipment capable of removing rust scale from reinforcing steel, removing small chips of concrete partially loosened by the scarifying or chipping operation, and for removing rehydrated dust left from scarification.
- (F) Power driven hand tools for removal of unsound concrete are required that meet the following requirements:
  - (1) Pneumatic hammers weighing a nominal 35 lb or less.
  - (2) Pneumatic hammer chisel-type bits that do not exceed the diameter of the shaft in width.
- (G) Hand tools such as hammers and chisels for removal of final particles of unsound concrete.
- (H) Self-propelled vacuum capable of picking up water, dust, and other loose material from prepared deck surface.
- (I) Vibratory screed for overlays, except as noted herein.

The hydro-demolition machine shall be self-propelled and capable of producing a water-jet through an orifice at a pressure of at least 17,000 psi. The machine shall move the jet transversely across the area and forward and backward so that the entire deck is covered with the water-jet and operated at a pressure sufficient to remove the unsound concrete.

The machine shall have sufficient means to control and vary the following functions:

- (A) Water pressure.
- (B) Angle and distance of the orifice in relation to the surface to be blasted.
- (C) Limits of transverse and longitudinal movement of the orifice.

(D) Speed of the orifice in the transverse and longitudinal direction.

High pressure pump(s) shall be equipped with over-pressurization relief valves and rupture disc systems. All high pressure components shall be rated at full working pressure of the hydro-demolition system. The complete hydro-demolition system must be capable of depressurization from a single point.

The equipment must operate at a noise level less than 90 decibels at a distance of 50 feet.

#### **MANAGEMENT AND DISPOSAL OF CONCRETE GRINDING RESIDUALS**

The contractor must collect and properly dispose of water, Hydro-demolition Operation Slurry (HOS), Diamond Grinding Slurry (DGS), and solids from bridge deck preparation, otherwise referred to as Concrete Grinding Residuals (CGR). Prior to beginning work, submit for approval by the Engineer an HOS/DGS Management Plan. Prepare the plan in accordance with the NCDOT Guidelines on the Management and Disposal of CGR available at:

[https://connect.ncdot.gov/resources/Environmental/Environmental Permits and Guidelines/Forms/AllItems.aspx](https://connect.ncdot.gov/resources/Environmental/Environmental%20Permits%20and%20Guidelines/Forms/AllItems.aspx)

The contractor shall comply with applicable regulation concerning such water disposal.

Prior to final payment, the contractor must submit a paper copy of all completed records pertaining to disposal of CGR. All costs associated with Management and Disposal of CGR shall be included in the payment of other items.

#### **OSP PLAN SUBMITTAL**

Prior to beginning surface preparation activities, the Contractor shall submit for review and approval the Overlay Surface Preparation (OSP) Plan. The OSP Plan shall detail the type of equipment that is intended to be used and the means by which the Contractor will achieve the following requirements:

- (A) Estimate depth of reinforcing steel.
- (B) Scarification of deck to required depth.
- (C) Field verification that required scarification depth was achieved within limits.
- (D) Hydro-demolition of deck with appropriate profile and to required depth.
- (E) Field verification that the required hydro-demolition depth was achieved within limits.

#### **SURFACE PREPARATION**

Remove all existing asphalt overlays and all loose, disintegrated, unsound or contaminated concrete to the limits shown on the plans with the following requirements:

- (A) Sealing of Bridge Deck: Seal all expansion joints subject to run-off water from the hydro-demolition process with material approved by the Engineer, prior to beginning any demolition. The expansion joints shall remain sealed until water from the hydro-demolition process no longer passes over them. Take all steps necessary to eliminate the flow of water through the expansion joints, and any other locations water could leak from the deck.

All deck drains in the immediate work area and other sections of the bridge affected by the work being performed shall be sealed prior to beginning scarification. Drains shall remain sealed until it has been determined that materials from the hydro-demolition and concrete overlay operations cannot be discharged through them any longer.

- (B) Scarifying Bridge Deck: Removal of any asphalt wearing surface from the bridge deck and scarification of the entire surface of the concrete deck to remove concrete to a uniform depth within  $\frac{1}{2}$ " of the plan overlay thickness, but not less than  $\frac{1}{2}$ " inch above the top mat of reinforcing steel.

It will be the Contractor's responsibility to determine amount of cover for the reinforcing steel. Use a pachometer or other approved device, as directed by Engineer, prior to beginning hydro-demolition. Readings shall be taken in the presence of the Engineer. Readings should be taken for each span at 1/5 points longitudinally and 1/3 points transversely. This cost for this work will be considered incidental to the cost of hydro-demolition of the bridge deck.

**Estimated average cover to top mat:**

**Bridge # 620049: 1 7/8" +/-3/8"**

**Bridge # 620072: 1 7/8" +/-3/8"**

The above top mat cover dimensions are an estimate based on the best available information. Calibrate scarifying equipment in order to avoid damaging the reinforcing steel in the bridge floor or the approach slab. If reinforcing bars or bridge drainage devices are pulled up or snagged during operations, then cease work and consult with the Engineer to determine any necessary adjustments to the scarifying operation.

Remove and dispose of all concrete and asphalt, and thoroughly clean the scarified surface. In areas where reinforcing steel is located in the depth to be scarified, use another method with the Engineer's approval.

- (C) Calibration of Hydro-Demolition Equipment: Two (2) trial areas shall be designated by the Engineer to demonstrate that the equipment, personnel, and methods of operation are capable of producing results to the satisfaction of the Engineer. The first trial area shall consist of approximately 50 square feet of sound concrete as determined by the Engineer. The equipment shall be calibrated to remove sound concrete from the scarified surface to the depth required to achieve the plan overlay thickness. After completion of this test area, the equipment shall be moved to the second area consisting of deteriorated or defective concrete, to determine whether unsound concrete will be completely removed with the previous calibration and to establish a baseline for requiring the contractor to place under-deck containment in areas subject to full depth removal, before beginning the hydro-demolition process in a span. Should it be determined that not all defective concrete has been removed, the hydro-demolition system shall be recalibrated to remove an additional  $\frac{1}{4}$ " of sound concrete, then re-test on deteriorated concrete.

If additional defective concrete is found, the depth of cut will increase in  $\frac{1}{4}$ " increments until only sound concrete is found remaining.

When satisfactory results are obtained, the machine parameters shall be used for production removal. The contractor shall make adjustments to the operating parameters, as required, to perform concrete removal as indicated on the plans and to adjust to the variance in the compressive strength of the concrete.

Hand held water blasting equipment, pneumatic hammers, and hand tools may be substituted for the hydro-demolition unit in inaccessible or inconvenient areas.

- (D) Hydro-demolition (Overlay Depth): Remove by hydro-demolition or chipping with hand tools all loose, unsound and contaminated deck concrete and, if necessary, sound concrete in order to allow for the placement of an overlay with the minimum depth shown on the plans. In areas where reinforcing steel is exposed and debonded for a length greater than two (2) feet, remove deck to an average depth of ½” below the exposed and debonded reinforcing steel. Reinforcing steel that is exposed and loose shall be tied to the crossing bar(s) as needed to secure the steel. Reinforcing steel shall be considered loose if when struck, movement or vibration can be observed. Concrete below crossing bar shall be removed as necessary to tie reinforcing steel to crossing bar with a wire tie. Dispose of the unsound concrete, clean, repair or replace damaged reinforcing steel and thoroughly clean the newly exposed surface.

Care shall be taken not to cut, stretch, or damage any exposed reinforcing steel.

The Engineer will re-inspect after each removal and require additional removals until compliance with plans and specifications are met.

Any areas of the prepared surface contaminated by oil or other materials detrimental to good bond as a result of the contractor’s operations shall be cleaned at the contractor’s expense.

Regardless of the method of removal, the removal operation shall be stopped if it is determined that sound concrete is being removed to a depth greater than required by the plans including any ¼” increments added per the above calibration process.

Appropriate recalibration, or change in equipment and methods shall be performed prior to resuming the removal operation.

- (E) Class II Surface Preparation (Partial Depth): At locations specified on the plans for Class II Surface Preparation, verify the depth of removal achieved by the hydro-demolition. The average depth of removal shall be approximately one-half the deck thickness but not less than ¾” below the top mat of steel. When hydro-demolition did not achieve the Class II Surface Preparation depth requirements, remove by hydro-demolition or chipping with hand tools all existing patches and contaminated concrete to the required depth. No additional payment will be made for Class II Surface Preparation depths achieved by the initial hydro-demolition.

All patches shall be removed under Class II Surface Preparation. If any patch cannot be removed by means of hydro-demolition, the Contractor shall use hand tools to remove the patch. Areas indicated on the plans that require Class II Surface Preparation, including the locations of existing patches, are from the best information available. The Contractor shall verify prior to surface preparation the location of all existing patches.



Dispose of the removed concrete, clean, repair or replace rusted or loose reinforcing steel and thoroughly clean the newly exposed surface. Care shall be taken not to cut, stretch, or damage any exposed reinforcing steel.

In overhangs, removing concrete areas of less than 0.60 ft<sup>2</sup>/ft. length of bridge without overhang support is permitted unless the Engineer directs otherwise. Overhang support is required for areas removed greater than 0.60 ft<sup>2</sup>/ft. length of bridge. Submit details of overhang support to the Engineer for approval prior to beginning the work.

Class III Surface Preparation (Full Depth): Remove by hydro-demolition or chipping with hand tools the full depth of slab. Dispose of the removed concrete, clean, repair or replace damaged reinforcing steel and thoroughly clean the newly exposed surface. Care shall be taken not to cut, stretch, or damage any exposed reinforcing steel.

For areas of less than 3 ft<sup>2</sup> suspending forms from existing reinforcing steel using wire ties is permitted. For larger areas, support forms by blocking from the beam flanges, or other approved method.

Overhang support is required for full depth removal adjacent to bridge rails. Submit details of overhang support to the Engineer for approval prior to beginning the work.

Under Deck Containment: Under deck containment shall be installed where Class III surface preparation occurs. The containment shall be installed prior to hydro-demolition in the areas where full depth removal is required or blow through may occur during the hydro-demolition process.

Submit for approval detailed plans for the under deck containment system. Detail how waste, debris, and wastewater are contained.

(F) Concrete for Full Depth Repair: Fill the Class III surface preparation areas with Class AA, high early strength structural concrete or latex modified concrete in accordance with one of the methods described below:

Refill full depth areas with Class AA concrete to the bottom of the proposed concrete overlay in accordance with Section 420 of the *Standard Specifications*. Any of the methods for curing Class AA concrete as stated in the *Standard Specifications* are permitted except the membrane curing compound method.

Provide a raked finish to the surface of the Class AA concrete which provides a minimum relief of  $\frac{1}{16}$ " and a maximum relief of  $\frac{1}{4}$ ".

Verify the Class AA concrete has attained a minimum compressive strength of 3,000 psi using an approved, non-destructive test method. Brush a lean mix of the latex modified concrete to the surface and immediately place the overlay course.

Refill full depth areas with high early strength concrete as described in the *Concrete for Deck Repair and Volumetric Mixer Special Provisions*.

Refilling full depth areas with latex modified concrete during the Class III repair is permitted if any of the following conditions are met:

- (a) The reinforcing steel cover is 1½ inches or less for the top mat of steel.
- (b) The area being repaired is less than 1 yd<sup>2</sup>.
- (c) The Engineer directs the fill.

(G) Preparation of Reinforcing Steel: Remove concrete without cutting or damaging existing steel unless otherwise noted in the plans. Damaged reinforcing steel, such as bars with nicks deeper than 20% of the bar diameter, shall be repaired or replaced. Reinforcing steel which has a cross section reduced to 75% or less shall be replaced with new reinforcing steel of similar cross section area. Replacement bars shall be Grade 60 and meet the material requirements of Section 1070 of the *Standard Specifications*. Replacement bars shall be spliced to existing bars using either minimum 30 bar diameter lap splices to existing steel with 100% cross sectional area or approved mechanical connectors. Support and protect the exposed reinforcing steel left unsupported by the hydro-demolition process against displacement and damage from loads such as those caused by removal equipment and delivery buggies. All reinforcing steel damaged or dislodged by these operations shall be replaced with bars of the same size at the contractor's expense.

Reinforcing steel exposed and cleaned by hydro-demolition will not require additional cleaning if encased in concrete within seven (7) days. Rebar exposed for more than seven (7) days shall be cleaned by high velocity water jets, with a minimum pressure 4,000 psi, prior to placement of the new concrete.

When large areas of the deck on composite bridges are removed resulting in the debonding of the primary reinforcing bars, the removal shall be performed in stages to comply with the construction sequence shown on the plans or as directed by the Engineer.

Safety: Provide a containment system for handling expected and unexpected blow through of the deck. The containment system shall retain runoff water and debris and protect the area under the bridge deck. The Contractor shall be responsible for any injury or damage caused by these operations. The containment system shall remain in place until the concrete has been cast and reach minimum strength.

Provide adequate lighting when performing hydro-demolition activities at night. Submit a lighting plan to the Engineer for approval prior to beginning work.

(H) Surface Cleaning: Removal of concrete debris shall be accomplished either by hand or mechanical means capable of removing wet debris and water in the same pass and after the hydro-demolition process to prevent debris from setting or adhering to the surface of the sound concrete. All concrete debris shall become the property of the Contractor and shall be legally disposed of at the contractor's expense. The contractor shall be responsible for disposing of all debris generated by the scarification operations. Any debris which is allowed to set or adhere to the surface of the sound concrete shall be carefully removed at no additional cost. Exercise care to avoid any damage to the remaining

sound concrete or exposed reinforcement. Prior to the placement of the overlay, the entire surface shall be cleaned with high pressure water to remove any bond-breaking residue, loose material from the concrete surface, and/or rust from the reinforcing steel. This residue shall be collected and disposed of by the contractor.

Any areas modified by chipping or hammering shall be cleaned with high pressure water at 7,500 psi minimum to remove any bond-breaking residue, loose concrete, and any deleterious material. This material shall be collected and disposed of by the contractor.

Any areas of the prepared surface contaminated by oil or other materials detrimental to good bond as a result of the contractor's operations shall be cleaned at the contractor's expense.

### **MEASUREMENT AND PAYMENT**

*Scarifying Bridge Deck* will be measured and paid for at the contract unit price per square yard for the milling of existing asphalt wearing surface from the bridge deck or approaches, milling of the entire concrete bridge deck, repairing or replacing any damaged reinforcing steel, and the cleaning and disposal of the milled material.

*Hydro-Demolition of Bridge Deck* will be measured and paid for at the contract unit price per square yard for hydro-demolition, removal and disposal of unsound and contaminated concrete, cleaning, repairing or replacing of reinforcing steel, and furnishing all materials, labor, tools, equipment and incidentals necessary to complete the work.

*Class II Surface Preparation* will be measured and paid for at the contract unit price per square yard and will be full compensation for Class II (partial depth) deck preparation where required by the plans and not attained by the initial hydro-demolition of the deck. The cost will also include removal and disposal of unsound and contaminated concrete, removal of all existing patches, cleaning, repairing or replacing of reinforcing steel, and all materials, labor, tools, equipment and incidentals necessary to complete the work.

*Class III Surface Preparation* will be measured and paid for at the contract unit price per square yard and will be full compensation for Class III (full depth) deck preparation and repair where required by the plans. The cost will also include removal and disposal of unsound and contaminated concrete, cleaning, repairing or replacing of reinforcing steel, under deck containment, placing and finishing concrete for full depth repair, and for furnishing all materials, labor, tools, equipment and incidentals necessary to complete the work.

Reinforcing Steel that is required for the repairs will be in accordance with Section 425 of the *Standard Specifications*.

Payment will be made under:

#### **Pay Item**

Scarifying Bridge Deck  
Hydro-Demolition of Bridge Deck  
Class II Surface Preparation  
Class III Surface Preparation

#### **Pay Unit**

Square Yard  
Square Yard  
Square Yard  
Square Yard

**LATEX MODIFIED CONCRETE OVERLAY – VERY EARLY STRENGTH (11-30-23)****GENERAL**

This Special Provision addresses the requirements for furnishing and placing an overlay of latex modified concrete - very early strength (LMC-VES) over existing concrete or repair concrete on bridge decks. Perform this work in accordance with this Special Provision and the applicable parts of the *Standard Specifications*.

**QUALITY CONTROL**

The Contractor is responsible for scheduling a pre-construction meeting with the Resident Engineer.

Submit a Quality Control Plan to the Engineer for approval which, at a minimum, describes the methods of: storing materials, calibrating mixers, controlling moisture content in the aggregate, maintaining proper mix temperature, retarder usage, curing and curing time, controlling evaporation rate, cleaning and removing excess water.

Prior to beginning work, provide proof of experience of the person in direct responsible charge by submitting a description of jobs similar in size and character that have been completed within the last five (5) years. The name, address and telephone number of references for the submitted projects shall also be furnished. Failure to provide appropriate documentation will result in the rejection of the proposed LMC-VES overlay Contractor.

Before beginning any work, obtain approval for all equipment to be used for deck preparation, mixing, placing, finishing and curing the LMC-VES.

**MATERIALS**

For materials, equipment, and proportioning and mixing of modified compositions, see Article 1000-8 of the *Standard Specifications*.

Provide aggregates for use in the LMC-VES that are free from ice, frost, frozen particles or other contaminants when introduced into the mixer.

Revise the *Standard Specifications* as follows:

**1000-8(A), Page 10-9, Line 21**– Add the following after the second sentence:

Use a calcium-aluminate cement from the Department's Approved Producer/Supplier list. Alternate cement types may be submitted for approval by the Engineer.

**1000-8(A), Page 10-10, Line 10**– Replace with the following:

Measure the slump immediately after discharge from the mixer, prior to citric acid being added.

**Table 1000-5, Page 10-10** – Revise as follows:

Replace 7 day Compressive Strength – 3,000 psi (min.) with 3 hour Compressive Strength – 3,000 psi (min.).

**1000-8(A)** – Add the following paragraph to the end of the section:

Submit the LMC-VES mix design, including laboratory compressive strength data for a minimum of six (6) 4-inch by 8-inch cylinders at three (3) hours for very early strength concrete to the Engineer for review. Include test results for the slump and the air content of the laboratory mix. Perform laboratory tests in accordance with AASHTO T 22, T 119, and T 152.

#### **PREPARATION OF SURFACE**

Completely clean all surfaces within 48 hours prior to placing the overlay unless otherwise approved by the Engineer. Placing material across expansion joints and sawing it later is not permitted.

Thoroughly soak the clean surface and maintain a wet surface for at least two (2) hours immediately prior to placing the LMC-VES. After soaking the surface for at least two (2) hours, cover it with a layer of white opaque polyethylene film that is at least 4 mils thick. Immediately prior to placing the LMC-VES, remove standing water from the surface using an approved vacuum system.

#### **CONCRETE FIELD SAMPLING**

An initial concrete sample of LMC will be taken in the inspection area prior to placing any concrete on the bridge. For each truck, discharge a minimum of three (3) cubic feet of material in the inspection area such that a homogeneous mix is produced prior to taking the initial concrete sample. Measure the temperature and slump of initial concrete sample prior to the truck leaving the inspection area. The initial concrete sample shall not include any citric acid.

A composite concrete sample of LMC will be taken in random areas of the bridge deck after a minimum of 2 cubic yards has been placed. The composite sample will be used to measure air content, and to produce four (4) 4-inch by 8-inch cylinders for compressive strength tests. The composite sample shall be taken before the concrete is vibrated, screeded, or finished in any way.

#### **PLACING AND FINISHING**

Prior to placing LMC-VES, install a bulkhead of easily compressible material at expansion joints to the required grade and profile.

Construction joints other than those shown on the plans will not be permitted unless approved by the Engineer. At construction joints, remove 4" of previously placed LMC-VES prior to placing the adjacent latex concrete. Also, for longitudinal construction joints, 4" of previously poured LMC-VES shall be scarified, hydro-demolitioned and recast with the next stage.

Place and fasten screed rails in position to ensure finishing the new surface to the required profile. Do not treat screed rails with parting compound to facilitate their removal. Prior to placing the overlay attach a filler block to the bottom of the screed and pass it over the area to be repaired to check the thickness. The filler block thickness shall be equal to the design overlay thickness as shown in the plans. Remove all concrete that the block does not clear. Individual aggregates left after hydro-demolition may be allowed to project above the base of the filler block. Remove aggregate that does not provide a 1" clear cover to the top of the overlay.

Brush a latex cement mixture onto all vertical surfaces and do not let the brushed material dry before it is covered with the additional material required for the final grade. Remove all loose aggregate from the latex cement brushed surface prior to latex concrete placement (NOTE: For surfaces not prepared with hydro-demolition brush the lean latex mixture over horizontal and vertical surfaces).

Do not place the LMC-VES until the burlap is fully saturated and approved by the Engineer. Drain excess water from the wet burlap before placement.

Place the LMC-VES in one operation. Provide a minimum overlay thickness as shown in the plans.

When a tight, uniform surface is achieved and before the concrete becomes non-plastic, further finish the surface of the floor by burlap dragging or another acceptable method that produces an acceptable uniform surface texture.

Once LMC-VES placement begins a single layer of wet burlap shall be placed five (5) feet behind the screed's burlap drag. In the event of a delay of ten (10) minutes or more, temporarily cover all exposed latex concrete with wet burlap and white opaque polyethylene.

Promptly cover the surface with a second layer of clean, wet burlap as soon as the surface will support it without deformation. Wet cure the surface for a minimum of three (3) hours and until a compressive strength of at least 2,500 psi is reached. Curing material shall be continually saturated during the wet cure period using a fogging system approved by the Engineer. The Engineer may require an increase in the minimum cure time when the overlay thickness is greater than 1.5 inches or the ambient temperature remains below 60°F.

Screed rails or construction dams shall be separated from the newly placed concrete by passing a pointing trowel along the face of the formwork and the newly placed concrete. Carefully make this trowel cut for the entire depth and length of rails or dams after the LMC-VES has sufficiently stiffened and cannot flow back.

As soon as practical, after the concrete has hardened sufficiently, test the finished surface with an approved rolling straightedge that is designed, constructed, and adjusted so that it will accurately indicate or mark all deck areas which deviate from a plane surface by more than 1/8" in 10'.

Remove all high areas in the hardened surface in excess of 1/8" in 10' with an approved grinding or cutting machine. Additionally, the final LMC-VES deck surface shall not deviate from the line and elevation indicated on the plans by more than 0.3" over any 50' length. Submit proposed corrective measures to the Engineer for approval for all low areas in excess of 1/8 inch in 10 feet.

Unless otherwise indicated on the plans, groove the bridge floor in accordance with Subarticle 420-14(B) of the *Standard Specifications*. Vehicular traffic may travel across a deck surface that has not been grooved; however, the entire deck area shall be grooved after the LMC-VES achieves design strength and no later than seven (7) days after completion of the overlay unless otherwise approved by the Engineer.

#### **LIMITATIONS OF OPERATIONS**

The mixer is not permitted on the bridge deck unless otherwise approved.

Do not place LMC-VES if the temperature of the concrete surface on which the overlay is to be placed is below 50°F or above 85°F. Measure the surface temperature by placing a thermometer under the insulation against the surface.

Prior to placing LMC-VES, the air temperature, wind speed, and the evaporation rate shall be determined by the Contractor and verified by the Engineer. Do not place LMC-VES if the ambient air temperature is below 50°F or above 85°F, or if the wind velocity is greater than 10 mph.

Do not place LMC-VES when the temperature of the LMC-VES is below 45°F or above 85°F.

It is the Contractor's responsibility to ensure that the rate of evaporation of surface moisture from the LMC-VES does not exceed 0.05 pounds per square foot per hour until the overlay has achieved the specified compressive strength. The evaporation rate is calculated using the following formula:

$$E = (T_c^{2.5} - r * T_a^{2.5}) * (1 + 0.4V) * (10^{-6})$$

where,

E = Evaporation Rate,

T<sub>c</sub> = Concrete Temp (°F),

r = Relative Humidity (%/100)

T<sub>a</sub> = Air Temp (°F),

V = Wind Velocity (mph)

The Contractor shall determine the evaporation rate prior to placement. Additionally, the Contractor shall determine the predicted evaporation rate from the beginning of the placement until the expected time of achieving the required compressive strength. If the calculated evaporation rate during that time exceeds or is predicted to exceed 0.05 pounds per square foot per hour, the Contractor may propose engineered controls of the parameters (temperature, relative humidity, wind velocity) to reduce the evaporation rate. The evaporation rate shall be recalculated, with the appropriate parameters, after the proposed control measures are in place. The recalculated evaporation rate shall be 0.05 pounds per square foot per hour or less, prior to placement, and must stay below 0.05 pounds per square foot per hour until the specified compressive strength is achieved.

Stop all placement operations during periods of precipitation. Take adequate precautions to protect freshly placed LMC-VES from sudden or unexpected precipitation. Keep an adequate quantity of protective coverings at the worksite to protect the freshly placed pavement from precipitation.

If working at night, provide approved lighting.

Do not allow traffic on the LMC-VES surface until the LMC-VES has attained a minimum compressive strength of 2,500 psi. Compressive strength for opening the bridge to traffic may be determined by compressive strength testing of sampled concrete cylinders, or by establishing a relationship between the compressive strength and rebound hammer readings, in lieu of compressive strength testing. For the correct procedure, refer to the document: *Rebound Hammer Calibration Procedure for use on Rapid Set Cement Latex Bridge Deck Overlays involving Multiple Bridges and/or Multiple Placement Days*, which is available from your local M&T representative or via the following link:

<https://connect.ncdot.gov/resources/Materials/MaterialsResources/Rebound%20Hammer%20Calibration%20Memo.pdf>

**ACCEPTANCE**

The minimum required acceptance strength for LMC-VES is 3,000 psi and will be based on the average compressive strength of two (2) 4-inch by 8-inch cylinders made from each truck for each load. These samples will be tested as close to 3 hours of age as possible, but not to exceed 24 hours of age from the time of sampling. The additional set of two (2) cylinders collected will be utilized for investigative purposes if the acceptance cylinders fail to meet strength requirements.

If the acceptance samples are more than 250 psi less than the rebound hammer readings from the deck, the rebound hammer shall be recalibrated per the above procedure.

**MEASUREMENT AND PAYMENT**

*Latex Modified Concrete Overlay– Very Early Strength* will be measured and paid for in cubic yards of LMC-VES satisfactorily placed on the completed deck.

*Placing & Finishing of Latex Modified Concrete Overlay – Very Early Strength* will be paid for at the contract unit price bid per square yard which includes compensation for furnishing all labor, tools, equipment and incidentals necessary to complete the work in accordance with the contract documents.

*Grooving Bridge Floors* will be measured and paid in accordance with Article 420-21 of the *Standard Specifications*.

Payment will be made under:

<b>Pay Item</b>	<b>Pay Unit</b>
Latex Modified Concrete Overlay – Very Early Strength	Cubic Yard
Placing & Finishing of Latex Modified Concrete Overlay – Very Early Strength	Square Yard
Grooving Bridge Floors	Square Feet

**OVERLAY SURFACE PREPARATION FOR****(08-08-22)****POLYMER CONCRETE****GENERAL**

This Special Provision addresses the surface preparation activities required prior to the placement of polymer concrete (PC). Unless specifically mentioned below, all requirements specified for the bridge deck are also required for the approach slabs.

Work includes: removal of unsound and sound bridge deck concrete and existing patches in deck repair areas; preparation of repair areas prior to placement of PC bridge deck repair material; bridge deck surface preparation prior to placement of PC overlay; and any incidentals necessary to prepare the bridge deck for placement of PC repair material or PC overlay, as specified or as shown on the plans.

**DEFINITIONS**

Scarification shall consist of the removal of any asphalt wearing surface and concrete surface to the uniform depth and limits shown on the plans.

Shotblasting shall consist of steel beads (or other materials as approved by the Engineer) “shot” out of a machine onto the bridge concrete deck concrete floor to remove soft or deteriorated concrete, and to clean the concrete deck surface for the application of the PC overlay. Contractor



shall vary the speed of the shotblaster or make multiple passes, as necessary, to achieve the required surface preparation for the PC overlay. Areas inaccessible with shotblasting equipment may require surface preparation with sandblasting equipment and hand equipment.

**EQUIPMENT**

All equipment for cleaning the existing concrete surface and mixing and applying the overlay system shall be in accordance with the System Provider's recommendations, as approved by the Engineer prior to commencement of any work:

- (A) Scarifying equipment that is a power-operated, mechanical grinder capable of removing a minimum depth of 1/4" for each pass.
- (B) Shotblasting and sandblasting equipment to adequately prepare the bridge deck substrate, as required in this Special Provision. Provide equipment to supply oil-free and moisture-free compressed air for final surface preparation.
- (C) Equipment capable of sawing concrete to the specified plan depth.
- (D) Power driven hand tools for removal of unsound concrete are required that meet the following requirements:
  - (1) Pneumatic hammers weighing a nominal 15 lbs. or less.
  - (2) Pneumatic hammer chisel-type bits that do not exceed the diameter of the shaft in width.
- (E) Hand tools, such as hammers and chisels, for removal of final particles of unsound concrete.
- (F) Self-propelled vacuum capable of picking up dust and other loose material from prepared deck surface.
- (G) Equipment to supply oil-free and moisture-free compressed air for final surface preparation.

The equipment must operate at a noise level less than 90 decibels at a distance of 50 feet.

**MANAGEMENT AND DISPOSAL OF CONCRETE DEBRIS**

All concrete debris shall become the property of the Contractor. The contractor shall be responsible for disposing of all debris generated by scarification, shotblasting, sandblasting, and any other surface preparation operations, in compliance with applicable regulations concerning such disposal.

All costs associated with management and disposal of all debris shall be included in the payment of other items.

**OSP PLAN SUBMITTAL**

Prior to beginning surface preparation activities, the Contractor shall submit for review and approval the Overlay Surface Preparation (OSP) Plan. The OSP Plan shall detail the type of equipment that is intended to be used and the means by which the Contractor will achieve the following requirements:

- (A) Estimate depth of reinforcing steel.
- (B) Scarification of deck to depth required.

- (C) Measure depth of scarification to show completed within limits.
- (D) Measure depth of shotblasting to show completed within limits.

The OSP Plan shall also include a schedule showing lane closures with estimated amount of bridge deck to be scarified, anticipated areas of Class II/III to be repaired and PC to be placed within that lane closure time. The Contractor should assume that any surface that is scarified shall be covered with the proper PC overlay before traffic is returned to the bridge deck, unless otherwise approved by the Engineer. The Contractor may propose traffic to be allowed on scarified bridge deck surfaces provided that the surface and joints are found to be structurally sound after scarification and a smooth transition is provided at the leading and trailing ends and throughout the bridge surface. The duration between bridge deck scarification and PC placement shall be specified by the Engineer. The number of bridges, if any, that can be scarified in advance of PC placement shall be specified by the Engineer. Any additional approach work required to provide a smooth transition to the scarified surface before opening to traffic is incidental to the other items of work. The OSP plan shall clearly show the Contractor's intended plan and order of scarifying and placing PC on all bridges with associated timeframes. The OSP plan and associated scarification timeframes must be approved by the Engineer prior to starting any surface preparation operations.

#### **SURFACE PREPARATION**

Prior to any construction, take the necessary precautions to ensure debris from bridge deck preparation and repairs is not allowed to fall below the bridge deck.

Remove all existing asphalt overlays and all loose, disintegrated, unsound or contaminated concrete to the limits shown on the plans with the following requirements.

During surface preparation, precaution shall be taken to assure that traffic is protected from rebound, dust, and construction activities. Appropriate shielding shall be provided as required and directed by the Engineer. During surface preparation, the Contractor shall provide suitable coverings, as needed to protect all exposed areas not to receive overlay, such as curbs, sidewalks, parapets, etc. All damage or defacement resulting from surface preparation shall be repaired to the Engineer's satisfaction at no additional cost to the Department.

(A) Sealing of Bridge Deck: Seal all expansion joints subject to run-off water from the scarification, shotblasting, and PC placement process with material approved by the Engineer, prior to beginning any demolition. The expansion joints shall remain sealed until it has been determined that water and materials from the scarification, shotblasting, and PC placement operations cannot be discharged through them any longer. Take all steps necessary to eliminate the flow of water or materials through the expansion joints, and any other locations water or materials could leak from the deck.

All deck drains in the immediate work area and other sections of the bridge affected by the work being performed shall be sealed prior to beginning scarification. Drains shall remain sealed until it has been determined that water and materials from the scarification, shotblasting, and PC placement operations cannot be discharged through them any longer.

(B) Scarifying Bridge Deck: Remove any asphalt wearing surface from the bridge deck and scarify the concrete deck to remove the entire concrete surface of the deck to the uniform depth and limits shown on the plans.

It will be the Contractor's responsibility to determine amount of cover for the reinforcing steel. Use a pachometer or other approved device, as approved by Engineer, prior to scarification. Readings shall be read and recorded in the presence of the Engineer. Readings shall be recorded for each span at 1/5 points longitudinally and 1/3 points transversely. The cost for this work will be considered incidental to the cost of surface preparation of the bridge deck.

**Estimated average cover to top mat:**

**Bridge Number 180007 & 180477: 2 1/4" +/-1/2"**

The above top mat cover dimensions are an estimate based on the best available information. Calibrate scarifying equipment in order to avoid damaging the reinforcing steel in the bridge floor or the approach slab. Care shall be taken not to cut, stretch, or damage any exposed reinforcing steel. If reinforcing bars or bridge drainage devices are pulled up or snagged during scarification operations, cease work and consult with the Engineer to determine any necessary adjustments to the roto-milling operation.

Remove and dispose of all concrete and asphalt, and thoroughly clean the scarified surface. In areas where reinforcing steel is located in the depth to be scarified, use another method with the Engineer's approval.

The Engineer will re-inspect after each removal and require additional removals until compliance with plans and specifications are met.

Regardless of the method of removal, the removal operation shall be stopped if it is determined that sound concrete is being removed to a depth greater than required by the plans.

(C) Class II Surface Preparation (Partial Depth): At locations specified on the plans or identified by the Engineer for Class II Surface Preparation, verify the depth of removal achieved by the scarification. Remove by additional scarification or chipping with hand tools all existing patches and unsound concrete. No additional payment will be made for Class II Surface Preparation depths achieved by the initial scarification.

All patches shall be removed under Class II Surface Preparation. If any patch cannot be removed by means of scarification, the Contractor shall use hand tools to remove the patch. Areas indicated on the plans that require Class II Surface Preparation, including the locations of existing patches, are from the best information available. The Contractor shall verify prior to surface preparation the location of all existing patches.

Spalled or unsound areas of the deck not removed by scarification shall be removed to sound concrete at locations noted in the contract plans or as directed by the Engineer. Remove existing spalled or unsound areas of the bridge concrete deck by methods approved by the Engineer.

Provide a 1" deep saw cut around the perimeter of areas noted for bridge deck or patch removal. Remove, using the type of tools listed above, all concrete or patch material within the sawcut to a minimum depth of 1" and as necessary to remove unsound concrete. All loose and unsound concrete or patch material shall be removed.

Thoroughly clean the newly exposed surface to be free of all grease, oil, curing compounds, acids, dirt, or loose debris in accordance with this Special Provision.

Dispose of the removed concrete, clean, repair or replace rusted or loose reinforcing steel, and thoroughly clean the newly exposed surface. Care shall be taken not to cut, stretch, or damage any exposed reinforcing steel.

In overhangs, removing concrete areas of less than 0.60 ft<sup>2</sup>/ft length of bridge without overhang support is permitted unless the Engineer directs otherwise. Overhang support is required for areas removed greater than 0.60 ft<sup>2</sup>/ft length of bridge. Submit details of overhang support to the Engineer for approval prior to beginning the work.

- (D) Class III Surface Preparation (Full Depth): At locations specified on the plans or identified by the Engineer for Class III Surface Preparation, remove the concrete by chipping with hand tools the full depth of slab. Dispose of the removed concrete, clean, repair or replace damaged reinforcing steel and thoroughly clean the newly exposed surface. Care shall be taken not to cut, stretch, or damage any exposed reinforcing steel.

For areas of less than 3 ft<sup>2</sup>, suspending forms from existing reinforcing steel using wire ties is permitted. For larger areas, support forms by blocking from the beam flanges, or other approved method.

Overhang support is required for full depth removal adjacent to bridge rails. Submit details of overhang support to the Engineer for approval prior to beginning the work.

- (E) Preparation of Reinforcing Steel: Remove concrete without cutting or damaging existing steel unless otherwise noted in the plans. Clean, repair, or replace rusted or loose reinforcing steel. Damaged reinforcing steel, such as bars with nicks deeper than 20% of the bar diameter, shall be repaired or replaced. Reinforcing steel which has a cross section reduced to 75% or less shall be replaced with new reinforcing steel of similar cross section area.

Replacement bars shall be Grade 60 and meet the material requirements of Section 1070 of the *Standard Specifications*.

Replacement bars shall be spliced to existing bars using either minimum 30 bar diameter lap splices to existing steel with 100% cross sectional area or approved mechanical connectors.

For reinforcing steel left unsupported by the concrete removal process, support and protect the exposed reinforcing steel against displacement and damage from loads, such as those caused by removal equipment and delivery buggies. All reinforcing steel damaged or dislodged by these operations shall be replaced with bars of the same size at the contractor's expense.

Reinforcing steel exposed and satisfactorily cleaned and prepared will not require additional cleaning, if encased in concrete within seven (7) days. Rebar exposed for more than seven (7) days shall be satisfactorily cleaned and prepared, prior to placement of the new concrete. The satisfactory cleanliness and preparation of the reinforcing steel shall be determined by the Engineer.

When large areas of the deck on composite bridges are removed resulting in the debonding of the primary reinforcing bars, the removal shall be performed in stages to comply with the construction sequence shown on the plans or as directed by the Engineer.

- (F) Concrete Deck Repair: Repair and fill the Class II Surface Preparation areas of the existing bridge concrete deck prior to the final surface preparation and application of the PC overlay,

at locations shown in the plans, or as determined by the Engineer, if necessary. Materials other than PC may be used for concrete deck repairs, but shall be approved by the PC System Provider's Technical Representative and shall be applied and prepared as required by the PC System Provider. For concrete deck repairs with PC:

- (1) Removal and surface preparation of the repair area shall be in accordance with and shall be paid for under pay items in this Special Provision.
- (2) Materials, equipment, placement, and finishing of PC used for concrete deck repairs shall meet the requirements of and shall be paid for under pay items in the Polymer Concrete Bridge Deck Overlay Special Provision.

PC repair material may be placed up to one (1) hour prior to overlay placement.

All repairs shall be placed and finished to match substrate deck grade prior to PC placement, in order to provide a uniform overlay thickness.

Concrete deck repairs with PC may be utilized as a stand-alone item where required on structures not to receive a PC overlay.

(G) Surface Cleaning: The surface of concrete substrate and repaired areas shall be prepared for application of the overlay by shotblasting in order to remove all existing grease, slurry, oils, paint, dirt, striping, curing compound, rust, membrane, weak surface mortar, or any other contaminants that could interfere with the proper adhesion of the overlay system. The final prepared surface shall adhere to the following requirements:

- (1) If expansion joints are not being replaced or have been replaced prior to shotblasting they shall be protected from damage from the shotblasting operation. Deck drains and areas of curb or railing above the proposed surface shall be protected from the shotblasting operation.
- (2) The areas to receive overlay shall be cleaned by shotblasting, or abrasive sandblasting in the event that the shotblaster cannot access areas to be prepared. Do not begin shotblasting until all grinding or milling operations are completed. Cleaning shall not commence until all work involving the repair of the concrete deck surface has been completed and the deck is dry. All contaminants shall be picked up and stored in the vacuum unit and no dust shall be created during the blasting operation that will obstruct the view of motorists in adjacent roadways. The travel speed and/or number of passes of the shotblasting unit shall be adjusted, to result in all weak or loose surface mortar being removed, aggregates within the concrete being exposed, and open pores in the concrete exposed, as well as a visible change in the concrete color. Cleaned surfaces shall not be exposed to vehicular traffic unless approved by the Engineer. If the deck becomes contaminated before placing the overlay, the Contractor shall shotblast or abrasive sandblast the contaminated areas to the satisfaction of the Engineer at no additional cost to the Department.

- (3) Prior to the overlay placement, any loose particles shall be removed by magnets, oil free compressed air, and vacuuming, such that no trapped particles remain. Power washing will not be allowed.
  - (4) The areas to be overlaid shall be blown off with oil and moisture free compressed air just prior to placement of the primer and shall be completely dry.
  - (5) Cleaning methods other than those detailed by specification may be suggested by the PC System Provider and approved by the Engineer.
  - (6) All steel surfaces that will be in contact with the PC overlay shall be cleaned in accordance with Structural Steel Paint Council (SSPC) Surface Preparation (SP) No. 10, Near-White Blast Cleaning, except that wet blasting methods shall not be allowed.
- (H) Safety: Provide a containment system for handling expected and unexpected blow through of the deck. The containment system shall retain runoff water and debris and protect the area under the bridge deck. The Contractor shall be responsible for any injury or damage caused by these operations. The containment system shall remain in place until the concrete has been cast and attained minimum strength.

Provide adequate lighting when performing deck preparation activities at night. Submit a lighting plan to the Engineer for approval prior to beginning work.

#### **MEASUREMENT AND PAYMENT**

*Scarifying Bridge Deck* will be measured and paid for at the contract unit price per square yard and will be full compensation for the milling of existing asphalt wearing surface from the bridge deck and approaches, milling of the entire concrete bridge deck, repairing or replacing any damaged reinforcing steel, and the cleaning and disposal of all waste material generated.

*Shotblasting Bridge Deck* will be measured and paid for at the contract unit price per square yard and will be full compensation for the shotblasting and necessary sandblasting and handwork to prepare the entire concrete bridge deck and approaches, and removal and disposal of all waste material generated.

*Class II Surface Preparation* will be measured and paid for at the contract unit price per square yard and will be full compensation for Class II (partial depth) deck preparation where required by the plans. The cost will also include removal and disposal of unsound and contaminated concrete, removal of all existing patches, cleaning, repairing, or replacing of reinforcing steel, and all materials, labor, tools, equipment and incidentals necessary to complete the work.

*Class III Surface Preparation* will be measured and paid for at the contract unit price per square yard and will be full compensation for Class III (full depth) deck preparation and repair where required by the plans. The cost will also include removal and disposal of unsound and contaminated concrete, cleaning, repairing or replacing of reinforcing steel, under deck containment, placing and finishing concrete for full depth repair, and all materials, labor, tools, equipment and incidentals necessary to complete the work.

Reinforcing Steel that is required for the repairs will be in accordance with Section 425 of the *Standard Specifications*.

15BPR.130.3

**BP-35**

Chatham and Moore Counties

Payment will be made under:

**Pay Item**

Scarifying Bridge Deck  
 Shotblasting Bridge Deck  
 Class II Surface Preparation  
 Class III Surface Preparation

**Pay Unit**

Square Yard  
 Square Yard  
 Square Yard  
 Square Yard

**POLYMER CONCRETE BRIDGE DECK OVERLAY****(08-08-22)****GENERAL**

This work consists of furnishing and placing a Polymer Concrete (PC) overlay system with a resin primer on concrete surfaces. The surface of the concrete shall be prepared, and the PC overlay system shall be applied in accordance with this Special Provision in conformity with the lines, grades, thickness, and typical cross-sections shown on the plans or as approved by the Engineer. Unless specifically mentioned below, all requirements specified for the bridge deck are also required for the approach slabs.

The Contractor shall select one of the PC overlay systems below:

(A) Polyester Polymer Concrete (PPC) with a High Molecular Weight Methacrylate (HMWM) resin primer.

(B) Epoxy Polymer Concrete (EPC) with an epoxy resin primer.

Work includes: placement of resin primer; placement of PC surface patching and/or overlay; and any incidentals necessary to complete the project as specified or as shown on the plans.

The System Provider is the manufacturer that will provide the PC system for the PC overlay. The System shall include the necessary and appropriate PC components, as well as the necessary and appropriate resin primer components. Contractor shall not change System Provider during project, without approval from the Engineer.

**Qualifications And Submittals**

The Contractor shall submit the following requested items and any other relevant documents at least two (2) weeks prior to the PC Overlay Pre-placement Conference. These submittals are for approval and shall be directed to the Engineer.

(A) Overlay System: The Contractor shall submit two (2) copies of the System Provider's material information, written installation instructions, safety data sheets, and independent test results for approval.

(B) System Provider Qualifications: The Contractor shall install an overlay system with all components provided through a single System Provider with documented experience successfully supplying at least five (5) PC overlay projects of similar size and scope installed within the past five (5) years. The Contractor shall submit documentation of the System Provider's project experience including the following:

- (1) Project Location.
- (2) Owner Agency.

- (3) Project construction date.
- (4) Overlay quantities.
- (5) Reference name and contact information for owner representative.

(C) Contractor Qualifications: The Contractor shall submit documentation of successful projects placing structural concrete bridge decks, modified concrete bridge deck overlays, or PC overlay systems to finished grade using similar equipment as specified herein within the past five (5) years. A minimum of two (2) employees on site must have the equivalent work experience qualifications of the Contractor. The documentation of Contractors qualifications shall include the following:

- (1) Project Location.
- (2) Owner Agency.
- (3) Project construction date.
- (4) Overlay quantities.
- (5) Reference name and contact information for owner representative.

(D) System Provider Technical Representative Qualifications: The System Provider Technical Representative shall be an employee of the PC overlay system manufacturer, have a minimum of five (5) successful PC overlay projects within the last five (5) years, and be completely competent in all aspects of the work, including surface preparation, mixing, placement, curing, and testing of the PC overlay system. The Technical Representative shall have experience on a minimum of five (5) successful projects of similar size and scope. The Contractor shall submit documentation of the System Provider Technical Representative's experience including the following:

- (1) Years of Experience with PC overlay systems
- (2) Project location
- (3) Project construction date
- (4) Overlay quantities
- (5) Reference name and contact information for owner representative

The Technical Representative shall be available on site, for a minimum of three (3) days per project, to give the installer advice and guidance on the installation of PC overlay systems. This includes, but is not limited to: deck concrete surface preparation, PC overlay materials, PC overlay application, PC overlay curing or any time there are questions or issues that may arise. The Technical Representative shall be on site for the first PC overlay placement and shall remain on site until the Engineer is satisfied with the PC overlay preparation, placement, and finishing operations.

(E) Overlay Placement Plan: The Contractor shall submit an Overlay Placement Plan that includes the following:

- (1) Schedule of overlay work and testing for each bridge.
- (2) Anticipated concrete deck repair locations and repair method.
- (3) Staging plan describing overlay placement sequence including:



- (a) Construction joint locations. Longitudinal construction joints between passes shall be located along the centerline of travel lanes or edge of travel lanes.
  - (b) Sequence of placement.
  - (c) Placement widths.
  - (d) Anticipated placement lengths.
  - (e) Placement direction.
  - (f) Joint locations.
  - (g) Location of proposed trial overlay(s).
- (4) Description of equipment used for:
    - (a) Surface preparation including grinding and shotblasting.
    - (b) Applying resin primer.
    - (c) Measuring, mixing, placing, and finishing the PC overlay.
    - (d) Applying surface finish sand/fine aggregate.
  - (5) Method of protecting and finishing inlets and bridge drains.
  - (6) Method for isolating expansion joints.
  - (7) Method for measuring and maintaining overlay thickness and profile.
  - (8) Cure time for PC overlay.
  - (9) Storage and handling of resin primer and PC overlay components.
  - (10) Procedure for disposal of excess resin primer, PC overlay materials, and containers.
  - (11) Procedure for cleanup of mixing and placement equipment.
- (F) Equipment: The Contractor shall submit documentation of current certification that mixing equipment has been calibrated (Caltrans California test CT 109 or similar accepted). The Contractor shall submit a documented history of the use of the placement equipment to successfully place PC overlays on bridge projects for review and approval by the Engineer.

**MATERIALS**

The Polymer Concrete shall consist of a resin binder and aggregate as specified below. It shall also include a compatible primer which when mixed with other specified ingredients and applied as specified herein, is capable of producing a Polymer Concrete meeting the requirements of this specification.

- (1) Verification. The Contractor shall submit a Certified Test Report from independent labs for all of the materials associated with the PC overlay in accordance with this Special Provision.
- (2) Packaging and Shipment. All components shall be shipped in strong, substantial containers, bearing the manufacturer's label specifying batch/lot number, brand name, and quantity. If bulk resin is to be used, the contractor shall notify the Engineer in writing ten (10) working days prior to the delivery of the bulk resin to the job site. Bulk resin is any resin that is stored in containers in excess of 55 gallons.
- (3) Sampling. NCDOT reserves the right to retain and test samples of components of the PC overlay system. This includes requiring submittal of samples prior to the first installation or on-site sampling during construction.

Only use materials that are specified for the selected PC overlay system. Mixing materials from different PC overlay systems shall not be permitted.

(A) Polyester Polymer Concrete (PPC) materials shall consist of a polyester resin binder, a High Molecular Weight Methacrylate (HMWM) primer, and aggregate.

(1) Polyester Resin Binder: Polyester resin binder shall have the following properties:

- (a) Be an unsaturated isophthalic polyester-styrene co-polymer. The resin content shall be 12% +/-1% of the weight of the dry aggregate.
- (b) Contain at least 1 percent by weight gamma-methacryloxypropyltrimethoxysilane, an organosilane ester silane coupler.
- (c) Be used with a promoter that is compatible with suitable methyl ethyl ketone peroxide and cumene hydroperoxide initiators.
- (d) Meet the required values for the material properties shown in Table 1, below.

Accelerators or inhibitors may be required to achieve proper setting time of PPC. They shall be used as recommended by the overlay System Provider.

**Table 1**  
**POLYESTER RESIN BINDER PROPERTIES (PPC ONLY)**  
**(Each lot sent to job shall be tested)**

Property	Test Method	Requirement
Viscosity*	ASTM D 2196	75 – 200 cps (RVT No.1 Spindle, 20 RPM at 77 °F)
Specific Gravity*	ASTM D 1475	1.05 to 1.10 at 77 °F
Elongation	ASTM D 638	35 percent, minimum Type I specimen, thickness 0.25 ± 0.03” at Rate = 0.45 inch/minute.
	ASTM D 618	Sample Conditioning: 18/25/50+5/70
Tensile Strength	ASTM D 638	2,500 psi, minimum Type I specimen, thickness 0.25 ± 0.03” at Rate = 0.45 inch/minute.
	ASTM D 618	Sample Conditioning: 18/25/50+5/70
* Test shall be performed before adding initiator.		

(2) High Molecular Weight Methacrylate (HMWM) Primer: Primer for the substrate concrete surface shall be a wax-free, low odor, high molecular weight methacrylate primer, and consist of a resin, initiator, and promoter. The primer shall conform to requirements indicated in Table 2, below, and all components shall be supplied by the System Provider.

Initiator for the methacrylate resin shall consist of a metal drier and peroxide. If supplied separately from the resin, the metal drier shall not be mixed with the peroxide directly; a VIOLENT EXOTHERMIC REACTION will occur. The containers and measuring devices shall not be stored in a manner that allows leakage or spilling to contact the containers or materials of the other.

**Table 2**  
**HMWM PRIMER PROPERTIES (PPC ONLY)**  
**(Tested yearly)**

<b>Property</b>	<b>Test Method</b>	<b>Requirement</b>
Viscosity**	ASTM D 2196	25 cps maximum (Brookfield RVT with UL adapter, 50 RPM at 77 °F)
Volatile Content**	ASTM D 2369	30 percent, maximum
Specific Gravity**	ASTM D 1475	0.90 minimum at 77 °F
Flash Point	ASTM D 3278	180 °F minimum
Vapor Pressure**	ASTM D 323	1.0 mm Hg, maximum at 77 °F
PCC Saturated Surface-Dry Bond Strength (Adhesive)	California Test 551, part 5	700 psi, minimum at 24 hours and 70 ± 1°F (with PPC at 12% resin content by weight of the dry aggregate), primed surface
**Test shall be performed before initiator is added		

(B) Epoxy Polymer Concrete (EPC) materials shall consist of an epoxy resin binder/primer and aggregate.

- (1) Epoxy Resin Binder/Primer: Epoxy resin binder/primer shall have the following properties:
- Be a low viscosity epoxy resin. The resin content shall be 12% +/-1% of the weight of the dry aggregate.
  - Be 100% solids epoxy.
  - Be a two-part, low modulus epoxy resin.
  - Be moisture insensitive.
  - Meet the required values for the material properties shown in Table 3, below.

Accelerators or inhibitors may not be used to achieve proper setting time of EPC.

**Table 3**  
**EPOXY RESIN BINDER/PRIMER PROPERTIES (EPC ONLY)**  
**(Each lot sent to job shall be tested)**

<b>Property</b>	<b>Test Method</b>	<b>Requirement</b>
Viscosity	ASTM D 2196	75 – 150 cps (RVT No.1 Spindle, 20 RPM at 77 °F)
Specific Gravity	ASTM D 1475	1.05 to 1.08 at 77 °F
Elongation	ASTM D 638	35 percent, minimum Type I specimen, thickness 0.25 ± 0.03” at Rate = 0.45 inch/minute.
	ASTM D 618	Sample Conditioning: 18/25/50+5/70
Tensile Strength	ASTM D 638	2,800 psi, minimum Type I specimen, thickness 0.25 ± 0.03” at Rate = 0.45 inch/minute.
	ASTM D 618	Sample Conditioning: 18/25/50+5/70

(C) Aggregates: PC overlay aggregate shall be used for PPC and EPC and have the following properties:

- (1) No more than 45 percent crushed particles retained on the No. 8 sieve when tested in accordance with American Association of State Highway and Transportation Officials (AASHTO) Test Method T335.
- (2) Fine aggregate consists of natural sand only.
- (3) Weighted-average aggregate absorption of no more than 1.0 percent when tested under AASHTO Test Methods T84 and T85.
- (4) At the time of mixing with resin, have moisture content of not more than one-half ( $\frac{1}{2}$ ) of the weighted-average aggregate absorption when tested under AASHTO Test Method T255.
- (5) Moh's hardness of seven (7) or greater.
- (6) Comply with the requirements for the aggregate gradation indicated in Table 4, below:

**Table 4**  
**AGGREGATE GRADATION**  
(Tested yearly)

Sieve Size	Percent Passing
3/8"	100
No. 4	60-85
No. 8	55-65
No. 16	29-50
No. 30	16-36
No. 50	5-20
No. 100	0-7
No. 200	0-3

(D) Sand/Fine Aggregate: Sand or fine aggregate for an abrasive finish shall be used for PPC and EPC and have the following properties:

- (1) Commercial-quality blast sand/fine aggregate.
- (2) Not less than 95 percent pass the No. 8 sieve and not less than 95 percent retained on the No. 20 sieve when tested under AASHTO Test Method T27.
- (3) Shall be dry at the time of application.

(E) Composite system: The composite PC overlay system shall have the following properties indicated in Table 5, below:

**Table 5**  
**COMPOSITE PROPERTIES**  
**(Tested every 2 years)**

<b>Property</b>	<b>Test Method</b>	<b>Requirement</b>
PCC Saturated Surface Dry Bond Strength	CT 551	500 psi minimum at 24 hrs. and 70° F (without primer, at 12% resin content by weight of the dry aggregate, on Saturated Surface Dry Specimen)
Abrasion Resistance	CT 550	< 2g weight loss (at 12% resin content by weight of the dry aggregate)
Modulus of Elasticity	ASTM C 469	1,000,000 psi to 2,000,000 psi (at 12% resin content by weight of the dry aggregate)

#### Construction Requirements

- (A) PC Overlay Pre-placement Conference: A Pre-placement Conference shall be held before any overlay operations begin. Attendees shall include representatives from all parties involved in the work. If necessary, teleconferencing of attendees may be approved by the Engineer.
- (B) PC Overlay Placement Notice: Contractor shall provide a minimum 48 hours notice to the Engineer, prior to placement of PC overlay on any structure.
- (C) Trial Application: Prior to constructing the overlay, one or more trial applications shall be placed on a previously constructed concrete base to demonstrate proper initial set time and the effectiveness of the mixing, placing, and finishing equipment proposed. The set time can be determined as the time elapsed from resin catalyzation until the in-place PC trial application cannot be deformed by pressing with a finger, indicating the resin binder is no longer in a liquid state. Each trial application shall be the planned paving width, at least ten (10) feet long, and have the same thickness as the specified overlay. Conditions during the construction of the trial application(s) and equipment used shall be similar to those to be used for construction of the overlay. The location of the trial application(s) shall be approved by the Engineer. Trial applications shall be properly disposed of off-site by the Contractor, if removal is necessary. The number of trial applications required shall be as many as necessary for the Contractor to demonstrate the ability to construct an acceptable trial overlay section and competency to perform the work. However, the installer or proposed equipment/techniques may be rejected if not shown to be acceptable after three (3) trials.
- Overlay direct tension bond testing shall be performed in accordance with Section (F)(1) of this Special Provision. Acceptable test results shall be achieved on a trial application before the installation may proceed.
- (D) Equipment: All equipment for cleaning the existing concrete surface and mixing and applying the overlay system shall be in accordance with the System Provider's recommendations, as approved by the Engineer prior to commencement of any work.

- (1) Surface Preparation Equipment: Provide appropriate scarifying, shotblasting, sandblasting and other equipment to adequately prepare the bridge deck substrate, as required in the Overlay Surface Preparation for Polymer Concrete Special Provision.
- (2) Mixing Equipment: A continuous automated mixer shall be used for all PC overlay applications. The continuous mixer shall:
  - (a) Employ an auger screw/chute device capable of sufficiently mixing catalyzed resin with dry aggregate.
  - (b) Employ a plural component pumping system capable of handling binder resin and catalyst while maintaining proper ratios to achieve set/cure times within the specified limits. Catalyzed resin shall flow through a static mix tube for sufficient duration to completely mix the liquid system.
  - (c) Be equipped with an automatic metering device that measures and records aggregate and resin volumes. Record volumes at least every five (5) minutes, including time and date. Submit recorded volumes at the end of the work shift to the Engineer.
  - (d) Have a visible readout gage that displays volumes of aggregate and resin being recorded.
  - (e) Produce a satisfactory mix consistently during the entire placement.

A portable mechanical mixer of appropriate size for proposed batches, as recommended by the System Provider and approved by the Engineer, may be used for all PC patching applications and for smaller area overlay applications if approved by the Engineer.
- (3) Finishing Equipment: Finishing may be accomplished with a Self-Propelled Slip-Form Paving Machine or Vibratory Screed.
  - (a) Self-Propelled Slip-Form Paving Machine: A self-propelled slip-form paving machine, which is modified or specifically built to effectively place the PC overlay in a manner that meets the objectives and requirements of the project, may be used for PC overlay applications. The paving machine shall:
    - (i) Employ a vibrating pan to consolidate and finish the PC overlay.
    - (ii) Be fitted with hydraulically controlled grade automation to establish the finished profile. The automation shall be fitted with substrate grade averaging devices on both sides of the new placement; the device shall average 15 feet in front and behind the automation sensors; or the sensor shall be constructed to work with string-line control. It is acceptable to match grade when placing lanes adjacent to previously placed PC.
    - (iii) Be calibrated for the projects requirements and calibrated periodically following the manufacturers recommendations.
    - (iv) Have sufficient engine power and weight to provide adequate vibration of the finishing pan while maintaining consistent forward placement speed.
    - (v) Be capable of both forward and reverse motion under its own power.

- (b) Vibratory Screed: A vibratory screed may be used for finishing the PC overlay but must be approved by the Engineer at least two (2) weeks prior to PC overlay placement.
- (D) Concrete Deck Repairs and Surface Preparation: All areas that require removal of existing patches or unsound concrete shall be removed and prepared in accordance with the requirements of the Overlay Surface Preparation for Polymer Concrete Special Provision. Placement of concrete for deck repair material shall be Polymer Concrete in accordance with this Special Provision. Prepare all concrete deck and repaired deck surfaces in accordance with the requirements of the Overlay Surface Preparation for Polymer Concrete Special Provision.
- (E) Application of Overlay: Methods indicated in this Special Provision are typical of general installations and may be modified per the System Provider's recommendations as approved by the Engineer. The application of the overlay shall not begin until the concrete deck is completely surface dry in accordance with ASTM D4263, with a wait time revised from 16 hours to two (2) hours, or as directed by the System Provider's Technical Representative. Prior to overlay application, the concrete surface temperature shall be within the specified temperature ranges below. Night work may be required when temperatures cannot be met during the day.

(a) For PPC overlays, the concrete surface temperature shall be between 40° and 100° F.

(b) For EPC overlays, the concrete surface temperature shall be between 60° and 90° F.

During overlay application, precaution shall be taken to assure that traffic is protected from rebound, dust, and construction activities. Appropriate shielding shall be provided as required and directed by the Engineer.

During overlay application, the Contractor shall provide suitable coverings (e.g. heavy duty drop cloths) as needed to protect all exposed areas not to receive overlay, such as curbs, sidewalks, parapets, etc. All damage or defacement resulting from this application shall be cleaned and/or repaired to the Engineer's satisfaction at no additional cost to the Department.

- (1) Primer Application: Immediately before placing primer, all exposed surfaces shall be completely dry and blown clean with oil-free compressed air. Exposed surfaces shall be protected from precipitation and heavy dew during and after the application of the primer. After the exposed surfaces have been prepared and are dry, primer shall be applied in accordance with the System Provider's recommendations. Primer shall be placed within five (5) minutes of mixing at approximately 90-100 ft<sup>2</sup>/ gal or the rate acceptable to the Engineer.

Primer shall be applied by flooding and uniformly spread to completely cover surfaces to receive overlay. Care shall be taken to avoid heavy application that results in excess ponding. Excess material shall be removed or distributed to meet the required application rate. Primer shall be reapplied to any areas that appear dry prior to overlay placement.

Primer shall not be allowed to leak onto areas that have not received surface preparation.

- (2) PC Overlay Application: The PC overlay shall be applied during the interval between 15 minutes and two (2) hours after the primer has been applied. The PC overlay shall be placed prior to gelling. For PPC overlays, the overlay shall be placed within 15 minutes following

addition of initiator, unless otherwise recommended by the System Provider's Technical Representative.

The resin binder shall be initiated for PPC overlays and blended completely. Aggregate shall be added and mixed sufficiently.

The set time can be determined in the field when the in-place PC application cannot be deformed by pressing with a finger, indicating that the resin binder is no longer in a liquid state.

(a) When using PPC, the initial set time shall be at least 30 minutes and at most 90 minutes.

If the PPC initial set is not within 30 to 90 minutes, the material shall be removed and replaced.

(b) When using EPC, the initial set time shall be at least 30 minutes and at most 180 minutes. If the EPC initial set is not within 30 to 180 minutes, the material shall be removed and replaced.

The overlay shall be consolidated and finished to the required grade and cross-section using PC placement equipment as defined herein.

If placement is performed with a self-propelled slip-form paving machine, grade control shall be maintained by grade averaging devices (skis) or string-line control, as described in section: Construction Requirements, (D) Equipment, (3) Finishing Equipment, (a) Self-Propelled Slip-Form Paving Machine, (ii), unless otherwise allowed by the Engineer.

If a vibratory screed is used, prior to placing the PC overlay, place and fasten screed rails in position to ensure finishing the new surface to the required profile. Do not treat screed rails with parting compound to facilitate their removal. Prior to placing the overlay, attach a filler block to the bottom of the screed and pass it over the overlay area to check the thickness. The filler block thickness shall be equal to the design overlay thickness as shown in the plans. Remove all concrete that the block does not clear.

Place the PC overlay in one operation. Provide a minimum overlay thickness as shown in the plans.

Although the paver or screed may yield a finished or nearly finished surface, additional finishing may be necessary. The PC overlay shall be finished, as necessary, through traditional concrete finishing methods, producing a slight resin bleed indicating complete consolidation of aggregates.

Finishing of Polymer Concrete used as patching of an existing deck surface or overlay shall be completed and finished using traditional concrete hand finishing methods and hand concrete finishing tools. Such patches shall be placed flush with the top of the existing deck surface.

Resin content shall be as specified in the Materials section of this Special Provision and to yield a Polymer Concrete consistency that requires surface applied consolidation and finishing to consolidate aggregates and yield a slight sheen of bleed resin on top surface, yet does not yield excess bleed resin.

A surface friction sand/fine aggregate finish of at least 2.2 lbs/ yd<sup>2</sup> shall be broadcast onto the glossy surface immediately after sufficient finishing and before resin gelling occurs. To ensure adequate pavement friction, the completed PC overlay surface shall be free of



any smooth or "glassy" areas such as those resulting from insufficient quantities of surface aggregate. Any such surface defects shall be repaired by the Contractor in the manner recommended by the System Provider and approved by the Engineer at no additional cost to the Department.

All final edges of PC overlay not adjacent to barrier rail, parapet, or bridge deck joints shall be finished neat, straight, and square, unless otherwise noted on project plans or approved by the Engineer.

Unless otherwise indicated on the plans, groove the deck surface in accordance with Subarticle 420-14(B) of the *Standard Specifications*. Vehicular traffic may travel across a deck surface that has not been grooved; however, the entire deck area shall be grooved after the PC overlay achieves design strength and no later than seven (7) calendar days after completion of the overlay unless otherwise approved by the Engineer.

Before completion of the project, all deck joints shall be sawcut, prepared, and sealed according to the details in the plans.

After the PC material has set, if final sawcutting for joint seals will not be done within 12 hours, at minimum, a single sawcut shall be made at the approximate midpoint of each joint. The sawcut shall be made within 12 hours or prior to opening of PC placement to traffic, if traffic will be allowed within 12 hours. Two (2) saw cuts may be made, but final saw cutting for the joints shall be done in accordance with the Special Provisions for the installation of the joint seals.

Any surface that is scarified shall be covered with the PC overlay before traffic is returned to the bridge deck, unless otherwise approved by the Engineer.

Upon approval by the Engineer, if traffic is to be returned to the site, but the overlay is not completed within the allowable lane closure time and is more than  $\frac{3}{4}$  inch higher in elevation than the adjacent pavement, the PC overlay edges shall be tapered. The leading edge of the overlay shall be tapered at a 4:1 (horizontal: vertical) slope. Tapered edges longitudinal to the direction of traffic and tapered edges on the trailing edge of the overlay and shall be at a 45 degree slope. Tapers of 45 degrees may remain, and PC overlay may be placed adjacent. Tapers with a 4:1 (horizontal: vertical) slope shall be sawcut square to the overlay surface, prior to placing adjacent PC overlay.

The Contractor shall collect a ticket for each pass or portion of a pass that is provided by each mixer, and ensure that the following information is shown on each ticket:

- (a) Project Number.
- (b) Bridge Number.
- (c) Date and Time.
- (d) Location of Placement (Lane and Station Limits or location and length of placement along the length of the bridge).
- (e) Aggregate Weight.
- (f) Resin Binder Weight.

The tickets shall be available on site for Inspection personnel to use in tabulating quantities.

Curing: The Contractor shall allow the overlay to cure sufficiently before subjecting it to loads or traffic of any nature that may damage the overlay. Cure time depends upon the ambient and deck temperatures as well as initiator/accelerator levels.

The overlay shall be considered cured to a traffic ready state when a minimum reading of 25 on a properly calibrated Swiss hammer is achieved. Other rebound hammers may be use as approved by the Engineer.

(F) Acceptance Testing: Acceptance of the deck repairs, surface preparation, and PC overlay will be determined by the Engineer based on direct tension bond testing, and smoothness quality testing performed by the Engineer, assisted by the Contractor.

(1) Overlay Direct Tension Bond Testing: Direct tension bond (pull-off) tests shall be performed after 24 hours by the Contractor in accordance with ASTM C1583. At a minimum, three (3) direct tension bond tests shall be performed on each bridge overlay. For bridges with deck areas greater than 25,000 square feet, additional tests shall be performed at a frequency of one test per 25,000 square feet of additional deck area, rounded up. Additional testing may be required as directed by the Engineer.

The test result shall be the average of the tests for each structure. Test cores shall be drilled a minimum of 1/2" below the bond line.

The average minimum bond strength of the PC overlay system on normal weight concrete shall be 250 psi, with no individual test measured below 225 psi. An acceptable test will demonstrate that the overlay bond strength is sufficient, or by producing a concrete subsurface failure area greater than 50% of the test surface area. The Contractor shall repair all direct tension test locations with PC overlay in accordance with this Special Provision.

Direct tension bond testing shall be performed by an independent testing firm and shall be arranged by the Contractor. The Contractor may perform the direct tension bond testing with the approval of the Engineer. Testing shall be performed using a calibrated tensile loading device, in the presence of the Engineer. The tensile loading device shall be calibrated annually. The cost of direct tension bond testing shall be included in the bid price for *Placing and Finishing PC Overlay* item.

(2) Smoothness Quality Testing: As soon as practical after the PC overlay has hardened sufficiently, the Contractor shall test the finished surface with an approved rolling straightedge that is designed, constructed, and adjusted, so that it will accurately indicate or mark all deck areas which deviate from a plane surface by more than 1/8" in 10'. The Contractor shall remove all high areas in the hardened surface in excess of 1/8" in 10' with an approved grinding or cutting machine. Any fins or other protrusions remaining after grinding operations shall be removed to the satisfaction of the Engineer. Additionally, the final PC deck surface shall not deviate from the line and elevation indicated on the plans by more than 0.3" over any 50' length. If approved by the Engineer, correct low areas in an acceptable manner.

(G) Corrective Work

- (1) Repair of Surface Defects: The repair materials and finishing methods for surface defects in the overlay shall be in accordance with those used for the application of the overlay. All surface defects shall be repaired to the satisfaction of the Engineer before acceptance of the work is made.
- (2) Correction for Smoothness: Areas showing high spots of more than  $\frac{1}{8}$ " in 10' shall be marked and ground until the high spot does not exceed  $\frac{1}{8}$ " in 10'. Ground surface may be sawcut grooved to restore the texture if ordered by the Engineer. Areas showing low spots of more than  $\frac{1}{8}$ " in 10' shall be marked and a proposed repair procedure shall be submitted to the Engineer. The use of the proposed repair procedure shall be as recommended by the System Provider and approved by the Engineer.
- (3) Replacement of Defective Overlay: A defective overlay, or portion thereof, resulting in failing overlay pull bond test results shall be removed and replaced at the Contractor's expense. The Contractor shall submit a written corrective work proposal to the Engineer, which shall include the methods and procedures that will be used. The Contractor shall not commence corrective work until the methods and procedures have been approved in writing by the Engineer. The Engineer's approval shall not relieve the Contractor of the responsibility of producing work in conformity with the Contract.
- (4) Repair of Cracking: After a one-week cure period, if cracks are in the overlay, the Contractor shall fill the cracks with properly catalyzed and mixed primer material at no cost to the Department. Care shall be taken to fill the cracks only and ensure minimal primer material is left on the finished surface of the overlay.

## Measurement and Payment

*Concrete Deck Repair for PC Overlay* will be measured and paid for at the contract unit price bid per square yard and will be full compensation for placement of concrete deck repair material and shall include the cost of labor, tools, equipment and incidentals necessary to complete the work.

*Placing and Finishing PC Overlay* will be measured and paid for as the contract unit price bid per square yard of overlay placement and final surface finishing. Payment will be full compensation for all labor, equipment, and all incidentals necessary to complete the PC overlay placement. Construction and removal (if required) of trial application(s), including concrete base surfaces, will not be measured and paid for separately, but shall be incidental to complete the work. Tining of bridge deck, if used, will be incidental to this pay item.

*Grooving Bridge Floors* will be measured and paid in accordance with Article 420-21 of the *Standard Specifications*.

Only one of the following pay items shall be used for materials, dependent on the PC overlay system used.

- (A) *Polyester Polymer Concrete Materials* will be measured as the actual volume of PPC material complete-in-place. The volume shall include material used for overlay, patching of existing unsound concrete deck surface or overlays, and bridge deck concrete repairs as directed by the Engineer. Tickets provided to the project inspector, showing quantities of PPC produced, shall

15BPR.130.3

**BP-48**

Chatham and Moore Counties

be sufficient to calculate volume of material placed. Materials placed for trial application(s) shall be included in this Pay Item if placed and remaining on the bridge deck as part of the permanent overlay. *Polyester Polymer Concrete Materials* will be paid for at the contract unit price per cubic yard and will be full compensation to furnish the PPC material, including HMWM primer, freight to the project site, receiving, storage, and disposal of any unused PPC overlay material. Payment by cubic foot will be based on a 135 lbs/ ft<sup>3</sup> unit weight and quantities recorded by calibrated mixer unit readouts.

- (B) *Epoxy Polymer Concrete Materials* will be measured as the actual volume of EPC material complete-in-place. The volume shall include material used for overlay, patching of existing unsound concrete deck surface or overlays, and bridge deck concrete repairs as directed by the Engineer. Tickets provided to the project inspector, showing quantities of EPC produced, shall be sufficient to calculate volume of material placed. Materials placed for trial application(s) shall be included in this Pay Item if placed and remaining on the bridge deck as part of the permanent overlay. *Epoxy Polymer Concrete Materials* will be paid for at the contract unit price per cubic yard and will be full compensation to furnish the EPC material, including epoxy primer, freight to the project site, receiving, storage, and disposal of any unused EPC overlay material. Payment by cubic foot will be based on a 135 lbs/ ft<sup>3</sup> unit weight and quantities recorded by calibrated mixer unit readouts.

Payment will be made under:

<b><u>Pay Item</u></b>	<b><u>Pay Unit</u></b>
Concrete Deck Repair for Polymer Concrete Overlay	Square Yard
Placing & Finishing Polymer Concrete Overlay	Square Yard
Grooving Bridge Floors	Square Feet
Polyester Polymer Concrete Materials	Cubic Yard
Epoxy Polymer Concrete Materials	Cubic Yard

**VOLUMETRIC MIXER****(11-30-23)****GENERAL**

This Special Provision addresses the requirements for batching deck repair concrete at the point of delivery using a Mobile High Performance Volume Mixer (MHPVM). Work shall be in accordance with the general requirements of Section 1000-13 of the *Standard Specifications* and as amended by this Special Provision.

**MATERIALS**

Produce high early strength concrete with MHPVM equipment. Furnish project site storage facilities that will provide protection of materials in accordance with the *Standard Specifications* and all material suppliers' recommendations.

**EQUIPMENT**

MHPVM devices shall have prominently displayed stamped metal plate(s) from the Volumetric Mixers Manufacturers Bureau stating that the equipment conforms to the requirements of ASTM C685.

Hydraulic cement concrete shall be mixed at the point of delivery by a combination of materials and mixer unit conforming to the following:

- (A) The unit shall be equipped with calibrated proportioning devices for each ingredient added to the concrete mix. The unit shall be equipped with a working recording meter that is visible at all times and furnishes a ticket printout with the calibrated measurement of the mix being produced. If at any time the mixer fails to discharge a uniform mix, production of concrete shall be suspended until such time that problems are corrected.
- (B) Each unit shall have prominently displayed stamped metal plate(s) attached by the manufacturer on which the following are plainly marked: the gross volume of the transportation unit in terms of mixed concrete, the discharge speed and the mass calibrated constant of the machine in terms of volume.
- (C) MHPVMs shall be calibrated by a Department approved testing agency in accordance with the manufacturer's recommendations at an interval of every 6 months or a maximum production of 2,500 cubic yards, whichever comes first prior to use on the project. The yield shall be maintained within a tolerance of +/- 1% and verified using a minimum 2 cubic feet container every 500 cubic yards or a minimum of once per week.
- (D) The three (3) cubic feet initially discharged from the truck shall be discarded and not used for concrete placement. Acceptance of the concrete shall comply with the Standard Specifications except that the sample secured for acceptance testing will be taken after four (4) cubic feet is discharged from the delivery vehicle. During discharge, the consistency as determined by ASTM C143 on representative samples taken from the mixer discharge at random intervals shall not vary by more than 1 inch. Acceptance tests shall be performed on each load. If test data demonstrates that acceptable consistency of concrete properties is being achieved, the Engineer may reduce testing requirements.
- (E) MHPVM equipment shall be operated by a person who is a certified operator by the equipment manufacturer. Any equipment adjustments made during the on-site production of concrete shall be done under the direct on-site supervision of the producer's NCDOT Certified Concrete Batch Technician.

#### **UNIFORMITY AND ACCEPTANCE**

The contractor is responsible for providing a Certified Concrete Plant Technician during batching operations, and a Certified Concrete Field Technician during placing operations.

#### **MEASUREMENT AND PAYMENT**

*Volumetric Mixer* will be paid for as lump sum and will be full compensation for furnishing the certified MHPVM devices and calibration of the equipment.

15BPR.130.3

**BP-50**

Chatham and Moore Counties

Payment will be made under:

<b>Pay Item</b>	<b>Pay Unit</b>
Volumetric Mixer	Lump Sum

**BRIDGE JOINT DEMOLITION****(11-30-23)****GENERAL**

This special provision addresses the removal of existing joint material and adjacent concrete headers to facilitate the installation of new elastomeric concrete headers and bridge joint seals at the locations noted in the contract plans.

**EQUIPMENT**

Use the following surface preparation equipment:

- (A) Sawing equipment capable of sawing concrete to a specified depth.
- (B) Power driven hand tools for removal of concrete are required that meet the following requirements:
- (C) Pneumatic hammers weighing a nominal 15 lbs. (7 kg) or less
- (D) Pneumatic hammer chisel-type bits that do not exceed the diameter of the shaft in width.
- (E) Hand tools such as hammers and chisels for removal of final particles of concrete.

**REMOVAL AND PREPARATION**

Prior to any construction, take the necessary precautions to ensure debris from joint construction is not allowed to fall below the bridge deck.

Remove existing joint material by methods approved by the Engineer. Provide a 1" deep saw cut around the perimeter of areas noted for bridge deck removal.

Remove by chipping with hand tools concrete headers adjacent to the joint to the limits shown on the contract plans. Use a small chipping hammer (15 lb. class) to prepare the edges of the repair area to limit micro fractures. In addition, all loose and unsound concrete shall be removed.

In overhangs, removing concrete areas greater than 0.60 ft<sup>2</sup>/ft length of bridge will require overhang support. Submit the overhang support method to the Engineer for approval.

Care shall be taken not to cut, stretch, or damage any exposed reinforcing steel. Dispose of the removed concrete.

15BPR.130.3

**BP-51**

Chatham and Moore Counties

If the condition of the concrete is such that deep spalls or sheer faces result, notify the Engineer for the proper course of action.

Clean, repair or replace rusted or loose reinforcing steel. Thoroughly clean the newly exposed surface to be free of all grease, oil, curing compounds, acids, dirt, or loose debris.

**MEASUREMENT AND PAYMENT**

*Bridge Joint Demolition* will be measured and paid for at the contract unit price bid per square foot and will be full compensation for removal, containment and disposal of existing joint material and concrete and shall include the cost of labor, tools, equipment and incidentals necessary to complete the work.

<b>Pay Item</b>	<b>Pay Unit</b>
Bridge Joint Demolition	Square Feet

**FOAM JOINT SEALS FOR PRESERVATION****(11-30-23)****SEALS**

Use preformed seals compatible with concrete and resistant to abrasion, oxidation, oils, gasoline, salt, and other materials that are spilled on or applied to the surface. Use a resilient, UV stable, preformed, impermeable, flexible, expansion joint seal. The joint seal shall consist of low-density, closed cell, cross-linked polyethylene non-extrudable foam. The joint seal shall contain no EVA (Ethylene Vinyl Acetate). Cell generation shall be achieved by being physically blown using nitrogen. No chemical blowing agents shall be used in the cell generation process.

Use seals manufactured with grooves  $\frac{1}{8}$ "  $\pm$  wide by  $\frac{1}{8}$ "  $\pm$  deep and spaced between  $\frac{1}{4}$ " and  $\frac{1}{2}$ " apart along the bond surface running the length of the joint. Use seals with a depth that meets the manufacturer's recommendation, but is not less than 70% of the uncompressed width. Provide a seal designed so that, when compressed, the center portion of the top does not extend upward above the original height of the seal by more than  $\frac{1}{4}$ ". Provide a seal that has a working range of 30% tension and 60% compression and meets the requirements given below.

TEST	TEST METHOD	REQUIREMENT
Tensile Strength	ASTM D3575, Suffix T	110 – 130 psi
Compression Set	ASTM D1056 Suffix B, 2 hr recovery	10% - 16%
Water Absorption	ASTM D3575	< 0.03 lb/ft <sup>2</sup>
Elongation at Break	ASTM D3575	180% - 210%
Tear Resistance	ASTM D624 (D3575, Suffix G)	14 – 20 pli

Density	ASTM D3575, Suffix W, Method A	1.8 – 2.2 lb/ft <sup>3</sup>
Toxicity	ISO-10993.5	Pass (not cytotoxic)

Have the top of the joint seal clearly shop marked. Inspect the joint seals upon receipt to ensure that the marks are clearly visible before installation.

#### **BONDING ADHESIVE**

Use a two-component, 100% solid, modified epoxy adhesive supplied by the joint seal manufacturer that meets the requirements given below.

TEST	TEST METHOD	REQUIREMENT
Tensile strength	ASTM D638	3,000 psi (min.)
Compressive strength	ASTM D695	7,000 psi (min.)
Hardness	Shore D Scale	75-85 psi
Water Absorption	ASTM D570	0.25% by weight max.
Elongation to Break	ASTM D638	5% (max.)
Bond Strength	ASTM C882	2,000 psi (min.)

Use an adhesive that is workable to 40°F. When installing in ambient air or surface temperatures below 40°F or for application on moist, difficult to dry concrete surfaces, use an adhesive specified by the manufacturer of the joint seal.

#### **SAWING THE JOINT**

The concrete at the face of the joint (elastomeric concrete, polyester polymer concrete, Portland cement concrete, etc.) shall have sufficient time to cure such that no damage can occur to the concrete prior to sawing to the final width and depth as specified in the plans.

When sawing the joint to receive the foam seal, always use a rigid guide to control the saw in the desired direction. To control the saw and to produce a straight line as indicated on the plans, anchor and positively connect a template or a track to the bridge deck. Do not saw the joint by visual means such as a chalk line. Fill the holes used for holding the template or track to the deck with an approved flowable, non-shrink, non-metallic grout.

Saw cut to the desired width and depth in one (1) or two (2) passes of the saw by placing and spacing two (2) metal blades on the saw shaft to the desired width for the joint opening.

The desired depth is the depth of the seal plus ¼" above the top of the seal plus approximately 1" below the bottom of the seal. An irregular bottom of sawed joint is permitted as indicated on the plans. Grind exposed corners on saw cut edges to a ¼" chamfer.

Saw cut a straight joint, centered over the formed opening and to the desired width specified in the plans. Prevent any chipping or damage to the sawed edges of the joint.



Remove any staining or deposited material resulting from sawing with a wet blade to the satisfaction of the Engineer.

#### **PREPARATION OF SAWED JOINT FOR SEAL INSTALLATION**

The elastomeric concrete or polyester polymer concrete at the joint shall cure a minimum of 24 hours prior to seal installation. Portland cement concrete at the joint shall cure following the special provisions.

After sawing the joint, the Engineer will thoroughly inspect the sawed joint opening for spalls, popouts, cracks, etc. All necessary repairs will be made by the Contractor prior to blast cleaning and installing the seal, at no cost to the Department.

Clean the joints by sandblasting with clean dry sand immediately before placing the bonding agent. Sandblast the joint opening to provide a firm, clean joint surface free of curing compound, loose material and any foreign matter. Sandblast the joint opening without causing pitting or uneven surfaces. The aggregate in the joint concrete may be exposed after sandblasting.

After blasting, either brush the surface with clean brushes made of hair, bristle, or fiber, blow the surface with compressed air, or vacuum the surface until all traces of blast products and abrasives are removed from the surface, pockets, and corners.

If nozzle blasting is used to clean the joint opening, use compressed air that does not contain detrimental amounts of water or oil.

Examine the blast-cleaned surface and remove any traces of oil, grease, or smudge deposited in the cleaning operations.

Bond the seal to the blast-cleaned surface on the same day the surface is blast cleaned.

#### **SEAL INSTALLATION**

Install the joint seal according to the manufacturer's procedures and recommendations and as recommended below. Do not install the joint seal if the ambient air or surface temperature is below 45°F. Have a manufacturer's certified trained factory representative present during the installation of the first seal of the project.

Before installing the joint seal, check the uninstalled seal length to ensure the seal is the same length as the deck opening. When the joint seal requires splicing, use the heat welding method by placing the joint material ends against a Teflon heating iron of 425-475°F for 7 - 10 seconds, then pressing the ends together tightly. Do not test the welding until the material has completely cooled.

Begin installation by protecting the top edges of the concrete deck adjacent to the vertical walls of the joint as a means to minimize clean up. Stir each epoxy bonding agent component independently, using separate stirring rods for each component to prevent premature curing of the bonding agent. Pour the two (2) components, at the specified mixing ratio, into a clean mixing bucket. Mix the components with a low speed drill (400 rpm max.) until a uniform gray color is achieved without visible marbling. Apply bonding agent to both sides of the joint concrete, as well as both sides of the joint seal, making certain to fill completely the grooves with epoxy. With

gloved hands, compress the joint seal and with the help of a blunt probe, push the seal into the joint opening until the seal is recessed approximately ¼” below the surface. When pushing down on the joint seal, apply pressure only in a downward direction. Do not push the joint seal into the joint opening at an angle that would stretch the material. Seals that are stretched during installation shall be removed and rejected. Once work on placing a seal begins, do not stop until it is completed. Clean the excess epoxy from the top of the joint seal immediately with a trowel. Do not use solvents or any cleaners to remove the excess epoxy from the top of the seal. Remove the protective cover at the joint edges and check for any excess epoxy on the surface. Remove excess epoxy with a trowel, the use of solvents or any cleaners will not be allowed.

The installed system shall be watertight and will be monitored until final inspection and approval.

(A) Watertight Integrity Test

- (1) Upon completion of each foam seal expansion joint, perform a water test on the top surface to detect any leakage. Cover the roadway section of the joint from curb to curb, or barrier rail to barrier rail, with water, either ponded or flowing, not less than 1 inch above the roadway surface at all points. Block sidewalk sections and secure an unnozzled water hose delivering approximately 1 gallon of water per minute to the inside face of the bridge railing, trained in a downward position about six (6) inches above the sidewalk, such that there is continuous flow of water across the sidewalk and down the curb face of the joint.
- (2) Maintain the ponding or flowing of water on the roadway and continuous flow across sidewalks and curbs for a period of five (5) hours. At the conclusion of the test, the underside of the joint is closely examined for leakage. The foam seal expansion joint is considered watertight if no obvious wetness is visible on the Engineer’s finger after touching a number of underdeck areas. Damp concrete that does not impart wetness to the finger is not considered a sign of leakage.
- (3) If the joint system leaks, locate the place(s) of leakage and take any repair measures necessary to stop the leakage at no additional cost to the Department. Use repair measures recommended by the manufacturer and approved by the Engineer prior to beginning corrective work.
- (4) If measures to eliminate leakage are taken, perform a subsequent water integrity test subject to the same conditions as the original test. Subsequent tests carry the same responsibility as the original test and are performed at no additional cost to the Department.

Do not place pavement markings on top of foam joint seals.

**MEASUREMENT AND PAYMENT**

*Foam Joint Seals for Preservation* will be measured and paid for at the contract unit price bid per linear foot and will be full compensation for furnishing all material, labor, tools, and equipment necessary for installing these seals in place and accepted.

**Pay Item**

Foam Joint Seals for Preservation

**Pay Unit**

Linear Feet

**ELASTOMERIC CONCRETE FOR PRESERVATION****(2-11-19)****DESCRIPTION**

Elastomeric concrete is a mixture of a two-part polymer consisting of polyurethane and/or epoxy and kiln-dried aggregate. Provide an elastomeric concrete and binder system that is preapproved. Use the concrete in the blocked-out areas on both sides of the bridge deck joints as indicated on the plans.

**MATERIALS**

Provide materials that comply with the following minimum requirements at 14 days (or at the end of the specified curing time).

<b>ELASTOMERIC CONCRETE PROPERTIES</b>	<b>TEST METHOD</b>	<b>MINIMUM REQUIREMENT</b>
Compressive Strength, psi	ASTM D695	2000
5% Deflection Resilience	ASTM D695	95
Splitting Tensile Strength, psi	ASTM D3967	625
Bond Strength to Concrete, psi	ASTM C882 (C882M)	450
Durometer Hardness	ASTM D2240	50

<b>BINDER PROPERTIES (without aggregate)</b>	<b>TEST METHOD</b>	<b>MINIMUM REQUIREMENT</b>
Tensile Strength, psi	ASTM D638	1000
Ultimate Elongation	ASTM D638	150%
Tear Resistance, lb/in	ASTM D624	200

In addition to the requirements above, the elastomeric concrete must be resistant to water, chemical, UV and ozone exposure and withstand temperature extremes. Elastomeric concrete systems requiring preheated aggregates are not allowed.

**PREQUALIFICATION**

Manufacturers of elastomeric concrete materials shall submit samples (including aggregate, primer and binder materials) and a Type 3 certification in accordance with Article 106-3 of the *Standard Specifications* for prequalification to:

North Carolina Department of Transportation  
Materials and Tests Unit  
1801 Blue Ridge Road  
Raleigh, NC 27607

Prequalification will be determined for the system. Individual components will not be evaluated, nor will individual components of previously evaluated systems be deemed prequalified for use.

The submitted binder (a minimum volume of 1 gallon) and corresponding aggregate samples will be evaluated for compliance with the Materials requirements specified above. Systems satisfying all of the Materials requirements will be prequalified for a one (1) year period. Before the end of this period new product samples shall be resubmitted for prequalification evaluation.

If, at any time, any formulation or component modifications are made to a prequalified system that system will no longer be approved for use.

#### **INSTALLATION**

The elastomeric concrete shall not be placed until the reinforced concrete deck slab or overlay has cured for seven (7) full days and reached a minimum strength of 3,000 psi.

Provide a manufacturer's representative at the bridge site during the installation of the elastomeric concrete to ensure that all steps being performed comply with all manufacturer installation requirements including, but not limited to: weather conditions (ambient temperature, relative humidity, precipitation, wind, etc.), concrete deck surface preparation, binder and aggregate mixing, primer application, elastomeric concrete placement, curing conditions and minimum curing time before joint exposure to traffic. Do not place elastomeric concrete if the ambient air or surface temperature is below 45°F.

Prepare the concrete surface within 48 hours prior to placing the elastomeric concrete. Before placing the elastomeric concrete, all concrete surfaces shall be thoroughly cleaned and dry. Sandblast the concrete surface in the block-out and clear the surface of all loose debris. Do not place the elastomeric concrete until the surface preparation is completed and approved.

Prepare and apply a primer, as per manufacturer's recommendations, to all concrete faces to be in contact with elastomeric concrete, and to areas specified by the manufacturer.

Prepare, batch, and place the elastomeric concrete in accordance with the manufacturer's instructions. Place the elastomeric concrete in the areas specified on the plans while the primer is still tacky and within two (2) hours after applying the primer. Trowel the elastomeric concrete to a smooth finish.

15BPR.130.3

**BP-57**

Chatham and Moore Counties

The joint opening in the elastomeric concrete shall match the formed opening in the concrete deck prior to sawing the joint.

**FIELD SAMPLING**

Provide additional production material to allow freshly mixed elastomeric concrete to be sampled for acceptance. A minimum of six (6) 2-inch cube molds and three (3) 3-inch diameter x 6-inch cylinders will be taken by the Department for each day's production. Compression, splitting tensile, and durometer hardness testing will be performed by the Department to determine acceptance. Materials failing to meet the requirements listed above are subject to removal and replacement at no cost to the Department.

**BASIS OF PAYMENT**

*Elastomeric Concrete for Preservation* will be measured and paid for at the contract unit price bid per cubic foot and will be full compensation for material, labor, tools, and equipment necessary for satisfactorily installing the elastomeric concrete in place.

<b>Pay Item</b>	<b>Pay Unit</b>
Elastomeric Concrete for Preservation	Cubic Feet

**CONCRETE REPAIRS****(11-30-23)****GENERAL**

Work includes removal of concrete in spalled, delaminated and/or cracked areas of the existing bent caps, bent columns, underside of bridge decks, deck slabs, girders, and bridge rails in reasonably close conformity with the lines, depth, and details shown on the plans, described herein and as established by the Engineer. This work also includes straightening, cleaning, and replacement of reinforcing steel, doweling new reinforcing steel, removing all loose materials, removing and disposing of debris, formwork, applying repair material, and protecting adjacent areas of the bridge and environment from material leakage. The repair material shall be one of the materials described in this Special Provision, unless otherwise noted in the plans or Special Provisions.

The location and extent of repairs shown on the plans described herein are general in nature. The Engineer shall determine the extent of removal in the field based on an evaluation of the condition of the exposed surfaces. The Contractor shall coordinate removal operations with the Engineer. No more than 30% of a round or square column or 30% of the bearing area under a beam shall be removed without a temporary support system and approval from the Engineer.

Repair, to the Engineer's satisfaction, any portion of the structure that is damaged from construction operations. No extra payment is provided for these repairs.

**SURFACE PREPARATION**

Adhere to the following surface preparation requirements or the repair material manufacturer's requirements, whichever is more stringent.

Prior to starting the repair operation, delineate all surfaces and areas assumed to be deteriorated by visually examining and sounding the concrete surface with a hammer or other approved method. The Engineer is the sole judge in determining the limits of deterioration.

Prior to concrete removal, introduce a shallow saw cut, ½" in depth, around the repair area at right angles to the concrete surface. Sawcut should be located a minimum 2" beyond the perimeter of the deteriorated concrete area to be repaired. Remove all concrete within the sawcut to a minimum depth of ½". If concrete removal exposes reinforcing steel, remove all deteriorated concrete 1" below the reinforcing steel with a 17 lb (maximum) pneumatic hammer, with points that do not exceed the width of the shank, or with hand picks or chisels, as directed by the Engineer. Do not cut or remove the existing reinforcing steel. Unless specifically directed by the Engineer, do not remove concrete deeper than 1" below the reinforcing steel.

Abrasive blast all exposed concrete surfaces and existing reinforcing steel in repair areas to remove all debris, loose concrete, loose mortar, rust, scale, etc. After blasting, examine the reinforcing steel to ensure at least 90% of the original diameter remains. If there is more than 10% reduction in the rebar diameter, splice in and securely tie supplemental reinforcing bars as directed by the Engineer. This might require additional removal of concrete, in order to achieve an appropriate splice length of the reinforcing steel.

Thoroughly clean the repair area of all dirt, grease, oil, or foreign matter, and remove all loose or weakened material by abrasive blasting before applying concrete repair material. Acid etch with 15% hydrochloric acid, only if approved by the Engineer. Follow acid etching by scrubbing and flushing with copious amounts of clean water. Check the cleaning using moist pH paper. Water cleaning is complete when the paper reads ten (10) or higher.

Follow all abrasive blasting with vacuum cleaning.

The time between removal of deteriorated concrete and applying concrete repair material shall not exceed 72 hours. If the time allowance exceeds 72 hours, prepare the surface at the direction of the Engineer before applying concrete repair material.

**APPLICATION AND SURFACE FINISH**

Apply repair material to damp surfaces only when allowed by repair material recommendations and approved by the Engineer. Prepare damp surfaces in accordance with the *Standard Specifications* and/ or repair material manufacturer's recommendations. Use a blowpipe to facilitate removal of free surface water. Only oil-free compressed air is to be used in the blowpipe.

When surface preparation is completed, mix and apply repair material in accordance with the *Standard Specifications* and/ or repair material manufacturer's recommendations.

Use aggregate that is washed, kiln-dried, and bagged. Maximum size of aggregate shall not exceed 2/3 of the minimum depth of the repair area, or 3/4 of the depth of excavation behind the reinforcing steel, whichever is smaller.

Unless otherwise required by the repair material manufacturer, apply bonding agent to all repair areas immediately prior to placing repair material.

Repair areas shall be formed unless otherwise approved by the Engineer. Form and finish all repaired areas, including chamfered edges, as close as practicable to their original "As Built" dimensions and configuration. After applying the repair material, remove excessive material and provide a smooth, flush surface, unless directed otherwise.

Cure finished Class A concrete repair material by maintaining 95% relative humidity at the repair and surrounding areas by fogging, moist curing, or other approved means for seven (7) days. Cure polymer modified concrete repair material in accordance with manufacturer's recommendations.

#### **REPAIR MATERIAL OPTIONS**

##### **(A) Polymer Modified Concrete Repair Material**

Repair material shall be polymer modified cement mortar for vertical or overhead applications and shall be suitable for applications in marine environments. Material shall be approved for use by NCDOT. Submit repair material to the Engineer for review and approval prior to beginning the work. Color of repair material shall be concrete gray.

##### **(B) Class A Concrete Repair Material**

Repair material shall be Class A Portland Cement Concrete as described in Article 1000-3 of the *Standard Specifications*.

#### **TEMPORARY WORK PLATFORM**

Prior to beginning any repair work, provide details for a sufficiently sized temporary work platform at each repair location. Design steel members to meet the requirements of the *American Institute of Steel Construction Manual*. Design timber members in accordance with the *National Design Specification for Stress-Grade Lumber and Its Fastenings* of the National Forest Products Association. Submit the platform design and plans for review and approval. The design and plans shall be sealed and signed by a North Carolina registered Professional Engineer. Do not install the platform until the design and plans are approved. Drilling holes in the superstructure for the purpose of attaching the platform is prohibited. Upon completion of work, remove all anchorages in the substructure and repair the substructure at no additional cost to the Department.

#### **MEASUREMENT AND PAYMENT**

*Concrete Repairs* will be measured and paid for at the contract unit price bid per cubic foot and will be full compensation for removal, containment and disposal off-site of unsound concrete including the cost of materials, reinforcing steel, labor, tools, equipment and incidentals necessary to complete the repair work. Depth will be measured from the original outside concrete face. The Contractor and Engineer will measure quantities after removal of unsound concrete and before

application of repair material. Payment will also include the cost of abrasive blasting, surface cleaning and preparation, blast cleaning of reinforcing steel, placement of new reinforcing steel, cost of temporary work platform, testing of the soundness of the exposed concrete surface, furnishing and installation of repair mortar material, curing and sampling of concrete, and protection/cleaning of adjacent areas from splatter or leakage.

Reinforcing Steel that is required for the repairs will be in accordance with Section 425 of the *Standard Specifications*.

Payment will be made under:

<b>Pay Item</b>	<b>Pay Unit</b>
Concrete Repairs	Cubic Feet

### **SHOTCRETE REPAIRS**

**(11-30-23)**

#### **GENERAL**

The work covered by this Special Provision consists of removing deteriorated concrete from the structure in accordance with the limits, depth and details shown on the plans, described herein and as established by the Engineer. This work also includes removing and disposing all loose debris, cleaning and repairing reinforcing steel and applying structural shotcrete.

The location and extent of repairs shown on the plans are general in nature. The Engineer shall determine the extent of removal in the field based on an evaluation of the condition of the exposed surfaces.

Any portion of the structure that is damaged from construction operations shall be repaired to the Engineer's satisfaction, at no extra cost to the Department.

#### **MATERIAL REQUIREMENTS**

Use prepackaged dry mix shotcrete conforming to the requirements of ASTM C1480, the applicable sections of the *Standard Specifications* and the following:

Test Description	Test Method	Age (Days)	Specified Requirements
Silica Fume (%)	ASTM C1240	-	10 (Max.)
Air Content - As Shot (%)	ASTM C231 or ASTM C457	-	5 ± 2
Minimum Compressive Strength (psi)	ASTM C109	7 28	3,000 5,000
Minimum Bond Pull-off Strength (psi)	ASTM C1583 or ASTM C882	28	250



Rapid Chloride Permeability Tests (range in coulombs)	ASTM C1202	-	100 – 1,000
--	------------	---	-------------

Admixtures are not allowed unless approved by the Engineer. Store shotcrete in an environment where temperatures remain above 40°F and less than 95°F

All equipment must operate in accordance with the manufacturer's specifications and material must be placed within the recommended time.

### **QUALITY CONTROL**

#### (A) Qualification of Shotcrete Contractor

The shotcrete Contractor shall provide proof of experience by submitting a description of jobs similar in size and character that have been completed within the last five (5) years. The name, address and telephone number of references for the submitted projects shall also be furnished. Failure to provide appropriate documentation will result in the rejection of the proposed shotcrete contractor.

#### (B) Qualification of Nozzleman

The shotcrete Contractor's nozzleman shall be certified by the American Concrete Institute (ACI). Submit proof of certification to the Engineer prior to beginning repair work. The nozzleman shall maintain certification at all times while work is being performed for the Department. Failure to provide and maintain certification will result in the rejection of the proposed nozzleman.

### **TEMPORARY WORK PLATFORM**

Prior to beginning any repair work, provide details for a sufficiently sized temporary work platform at each repair location. Design steel members to meet the requirements of the American Institute of Steel Construction Manual. Design timber members in accordance with the *National Design Specification for Stress-Grade Lumber and Its Fastenings* of the National Forest Products Association. Submit the platform design and plans for review and approval. The design and plans shall be sealed and signed by a North Carolina registered Professional Engineer. Do not install the platform until the design and plans are approved. Drilling holes in the superstructure for the purpose of attaching the platform is prohibited. Upon completion of work, remove all anchorages in the substructure and repair the substructure at no additional cost to the Department.

### **SURFACE PREPARATION**

Prior to starting the repair operation, delineate all surfaces and areas assumed to be deteriorated by visually examining and sounding the concrete surface with a hammer or other approved method. The Engineer is the sole judge in determining the limits of deterioration.

Prior to removal, introduce a shallow saw cut approximately ½" in depth around the repair area at right angles to the concrete surface. Remove all deteriorated concrete 1 inch below the reinforcing steel with a 17 lb (maximum) pneumatic hammer with points that do not exceed the width of the

shank or with hand picks or chisels as directed by the Engineer. Do not cut or remove the existing reinforcing steel. Unless specifically directed by the Engineer, do not remove concrete deeper than 1 inch below the reinforcing steel.

Abrasive blast all exposed concrete surfaces and existing reinforcing steel in repair areas to remove all debris, loose concrete, loose mortar, rust, scale, etc. After sandblasting examine the reinforcing steel to ensure at least 90% of the original diameter remains. If there is more than 10% reduction in the rebar diameter, splice in and securely tie supplemental reinforcing bars as directed by the Engineer.

Provide stainless welded wire fabric at each repair area larger than one square foot if the depth of the repair exceeds 2 inches from the existing, intact exterior face of the concrete member. Provide a minimum 4" x 4" - 12 gage stainless welded wire fabric unless otherwise shown on the plans. Rigidly secure the welded wire fabric to existing steel or to  $\frac{3}{16}$ " diameter stainless hook fasteners adequately spaced to prevent sagging. Encase the welded wire fabric in shotcrete a minimum depth of 1½ inches.

With the exception of overhead applications, the contractor has the option to use synthetic fiber reinforcement as an alternate to welded wire fabric if attaching welded wire fabric is impractical or if approved by the Engineer. Welded wire fabric and synthetic fiber reinforcement shall not be used in the same repair area.

Thoroughly clean the repair area of all dirt, grease, oil or foreign matter, and remove all loose or weakened material before applying shotcrete. Saturate the repair area with clean water the day before applying shotcrete. Bring the wetted surface to a saturated surface dry (SSD) condition prior to applying shotcrete and maintain this condition until the application begins. Use a blowpipe to facilitate removal of free surface water. Only oil-free compressed air is to be used in the blowpipe.

The time between removal of deteriorated concrete and applying shotcrete shall not exceed five (5) calendar days. If the time allowance exceeds (5) calendar days, prepare the surface at the direction of the Engineer before applying shotcrete.

#### **APPLICATION AND SURFACE FINISH**

Apply shotcrete only when the surface temperature of the repair area is greater than 40°F and less than 95°F. Do not apply shotcrete to frosted surfaces. Maintain shotcrete at a minimum temperature of 40°F for three (3) calendar days after placement.

Apply shotcrete in layers. The properties of the applied shotcrete determine the proper thickness of each layer or lift.

The nozzleman should hold the nozzle three (3) to four (4) feet from the surface being covered in a position that ensures the shotcrete strikes at right angles to the surface being covered without excessive impact. The nozzleman shall maintain the water amount at a practicable minimum, so the mix properly adheres to the repair area. Water content should not become high enough to cause the mix to sag or fall from vertical or inclined surfaces, or to separate in horizontal layers.

Use shooting wires or guide strips that do not entrap rebound sand. Use guide wires to provide a positive means of checking the total thickness of the shotcrete applied. Remove the guide wires prior to the final finish coat.

To avoid leaving sand pockets in the shotcrete, blow or rake off sand that rebounds and does not fall clear of the work, or which collects in pockets in the work. Do not reuse rebound material in the work

If a work stoppage longer than two (2) hours takes place on any shotcrete layer prior to the time it has been built up to required thickness, saturate the area with clean water and use a blowpipe as outlined previously, prior to continuing with the remaining shotcrete course. Do not apply shotcrete to a dry surface.

Finish all repaired areas, including chamfered edges, as close as practicable to their original dimensions and configuration, unless otherwise required to provide a minimum 2" of cover for reinforcing steel exposed during repair. If necessary to extend shotcrete repair material beyond the original member dimensions and geometry, coordinate with the Engineer to determine methods, geometry, and dimensions of the final finished surface to provide a minimum 2" of cover on reinforcing steel. Slightly build up and trim shotcrete to the final surface by cutting with the leading edge of a sharp trowel. Use a rubber float to correct any imperfections. Limit work on the finished surface to correcting imperfections caused by trowel cutting.

Immediately after bringing shotcrete surfaces to final thickness, thoroughly check for sags, bridging, and other deficiencies. Repair any imperfections at the direction of the Engineer.

Cure the completed shotcrete surface in accordance with Article 420-15(B) Water Method of the *Standard Specifications* for seven (7) calendar days. If the water method is impracticable and if approved by the Engineer, a membrane curing compound may be used in accordance with Subarticle 420-15(C) of the *Standard Specifications* at double the manufacturer's recommended coverage rate.

#### **MATERIAL TESTING & ACCEPTANCE**

Each day shotcreting takes place, the nozzleman shall shoot one 18" x 18" x 3.5" test panel in the same position as the repair work that is being done to demonstrate the shotcrete is being applied properly. Store, handle and cure the test panel in the same manner as the repaired substructure and do not disturb for the first 24 hours after shotcreting.

Approximately 72 hours after completing the final shotcrete placement, thoroughly test the surface with a hammer. At this time, the repair area should have sufficient strength for all sound sections to ring sharply. Remove and replace any unsound portions prior to the final inspection of the work. No additional compensation will be provided for removal and replacement of unsound shotcrete.

In accordance with Subarticle 1002-3(H) of the *Standard Specifications*, core three (3) 3" diameter samples from each test panel. Compressive strength values on test panels shall equal or exceed the required 28-day strength requirements. Should failures occur on the test panel cores, acceptance of the material will be determined by tests on cores from the installed work on the structure. A minimum of (3) three cores shall be taken from the area in question of the structure. The average

15BPR.130.3

**BP-64**

Chatham and Moore Counties

compressive strength of the cores taken from the structure shall equal or exceed the specified strength of the shotcrete applied, and no single core shall have strength less than 85% of the specified value. Any cores taken from the structure shall penetrate into the existing concrete at least two (2) inches. Cores shall also be inspected for delamination, sand pockets, segregation, and voids.

The adequacy of the bond between the existing concrete and the shotcrete shall be determined by direct tension bond testing, in accordance with ASTM C1583 or ASTM C882, as directed by the Engineer. A minimum bond strength of 250 psi will be accepted as satisfactory. Bond failure less than 250 psi attributable to the failure of existing concrete will not be cause for rejection. The cost of up to three passing direct tension bond tests shall be the responsibility of the Contractor; additional passing pull-off tests will be the responsibility of the Department.

Any repair work failing to meet the requirements of this Special Provision will be rejected and the Contractor shall implement a remediation plan to correct the deficiency at no additional cost to the Department. No extra payment will be provided for drilling extra cores. Patch all core holes in the repaired structure to the satisfaction of the Engineer.

**MEASUREMENT AND PAYMENT**

*Shotcrete Repairs* will be measured and paid for at the contract unit price bid per cubic foot and will be full compensation for removal, containment and disposal off-site of unsound concrete including the cost of materials, labor, tools, equipment and incidentals necessary to complete the repair work. Depth will be measured from the original outside concrete face. If modifications to the dimensions and geometry are approved by the Engineer to achieve proper clearance over reinforcing steel, depth measurements will be made from the modified final outside face. The Contractor and Engineer will measure quantities after removal of unsound concrete and before application of repair material. Payment will also include the cost of sandblasting, surface cleaning and preparation, cleaning of reinforcing steel, placement of new steel, cost of temporary work platform, testing for soundness and bond strength, curing of shotcrete and taking core samples from the test panels and the structure.

Payment will be made under:

<b>Pay Item</b>	<b>Pay Unit</b>
Shotcrete Repairs	Cubic Feet

**EPOXY RESIN INJECTION****(08-08-22)****GENERAL**

For repairing cracks, an applicator certified by the manufacturer of epoxy injection system to be used is required to perform the epoxy resin injection. The Contractor shall submit documentation that indicates the firm, supervisor and the workmen have completed an instruction program in the methods of restoring concrete structures utilizing the epoxy injection process and have five (5) years of relative experience with a record of satisfactory performance on similar projects.

The Contractor furnishes all materials, tools, equipment, appliances, labor and supervision required when repairing cracks with the injection of an epoxy resin adhesive.

**SCOPE OF WORK**

Using Epoxy Resin Injection, repair all cracks 25 mils wide or greater in the interior bent columns and caps, in the ends of the girders, in the cantilevered portion of the ends of the girders, and in the cantilevered portion of the superstructure deck on the downstream side.

Repair the column cracks to the top of the drilled shafts or footings. Make the underwater repairs when water surface elevation is low and the water is still. For underwater repairs, use manufacturer recommended materials.

Repair any crack, void, honeycomb or spall area unsuitable for repair by injection with epoxy mortar, or as otherwise approved by the Engineer.

**SUBMITTALS**

Prior to construction, the Contractor shall submit the following to the Engineer for review and approval:

- (A) Materials – Information detailing the materials and their properties, storage and handling requirements, and Material Safety Data Sheets. Material certifications and sampling shall be required as per Section 106 of the NCDOT *Standard Specifications*.
- (B) Injection Procedures – Preparation and epoxy injection installation procedures, including written instructions from the manufacturer of the proportioning dispenser and the procedures recommended to monitor and assure its proportioning accuracy of the unit.
- (C) Contingencies – Proposed injection repair procedures in the event that during testing it is found that the injection installation procedure did not completely fill the cracks with epoxy.
- (D) Qualifications – The resumes of the Contractor's staff and/or the epoxy resin manufacturer's Technical Representative that will be on site performing the epoxy injection. The resumes shall detail the installer's applicable certifications and epoxy injection installation experience.
- (E) References – The names and telephone numbers of contact persons for recent (< 2years?) epoxy injection projects.

**COOPERATION**

Cooperate and coordinate with the Technical Representative of the epoxy resin manufacturer for satisfactory performance of the work.

Have the material manufacturer's Technical Representative present when the epoxy resin injection process begins and until the Engineer is assured that their service is no longer needed.

The expense of having this representative on the job is the Contractor's responsibility at no additional cost to the Department.

15BPR.130.3

**BP-66**

Chatham and Moore Counties

**MATERIAL PROPERTIES**

Provide a two-component structural epoxy adhesive for injection into cracks or other voids. Provide modified epoxy resin (Component "A") that conforms to the following requirements:

	Test Method	Specification Requirements
Viscosity @ 40 ± 3°F, cps	Brookfield RVT Spindle No. 4 @ 20 rpm	6,000 – 8,000
Viscosity @ 77 ± 3°F, cps	Brookfield RVT Spindle No. 2 @ 20 rpm	400 - 700
Epoxide Equivalent Weight	ASTM D1652	152 - 168
Ash Content, %	ASTM D482	1 max.

Provide the amine curing agent (Component "B") used with the epoxy resin that meets the following requirements:

	Test Method	Specification Requirements
Viscosity @ 40 ± 3°F, cps	Brookfield RVT Spindle No. 2 @ 20 rpm	700 - 1400
Viscosity @ 77 ± 3°F, cps	Brookfield RVT Spindle No. 2 @ 20 rpm	105 - 240
Amine Value, mg KOH/g	ASTM D664*	490 - 560
Ash Content, %	ASTM D482	1 max.
		* Method modified to use perchloric acid in acetic acid.

Certify that the Uncured Adhesive, when mixed in the mix ratio that the material supplier specifies, has the following properties:

- Pot Life (60 gram mass)
  - @ 77 ± 3°F - 15 minutes minimum
  - @ 100 ± 3°F - 5 minutes minimum

Certify that the Adhesive, when cured for seven (7) days at 77 ± 3°F unless otherwise specified, has the following properties:

	Test Method	Specification Requirements
Ultimate Tensile Strength	ASTM D638	7,000 psi (min.)
Tensile Elongation at Break	ASTM D638	4% max.

Flexural Strength	ASTM D790	10,000 psi (min.)
Flexural Modulus	ASTM D790	3.5 x 10 <sup>5</sup> psi
Compressive Yield Strength	ASTM D695	11,000 psi (min.)
Compressive Modulus	ASTM D695	2.0 - 3.5 x 10 <sup>5</sup> psi
Heat Deflection Temperature Cured 28 days @ 77 ± 3°F	ASTM D648*	125°F min. 135°F min.
Slant Shear Strength, 5,000 psi (34.5 MPa) compressive strength concrete  Cured 3 days @ 40°F wet concrete  Cured 7 days @ 40°F wet concrete  Cured 1 day @ 77°F dry concrete	AASHTO T237	  3,500 psi (min.)  4,000 psi (min.)  5,000 psi (min.)
* Cure test specimens so the peak exothermic temperature does not exceed 77°F.		

Use an epoxy bonding agent, as specified for epoxy mortar, as the surface seal (used to confine the epoxy resin during injection).

#### **EQUIPMENT FOR INJECTION**

Use portable positive displacement type pumps with interlock to provide positive ratio control of exact proportions of the two (2) components at the nozzle to meter and mix the two (2) injection adhesive components and inject the mixed adhesive into the crack. Use electric or air powered pumps that provide in-line metering and mixing.

Use injection equipment with automatic pressure control capable of discharging the mixed adhesive at any pre-set pressure up to 200 ± 5 psi and equipped with a manual pressure control override.

Use equipment capable of maintaining the volume ratio for the injection adhesive as prescribed by the manufacturer. A tolerance of ± 5% by volume at any discharge pressure up to 200 psi is permitted.

Provide injection equipment with sensors on both the Component A and B reservoirs that automatically stop the machine when only one component is being pumped to the mixing head.

#### **PREPARATION**

Follow these steps prior to injecting the epoxy resin:

- (A) Remove all dirt, dust, grease, oil, efflorescence and other foreign matter detrimental to the bond of the epoxy injection surface seal system from the surfaces adjacent to the cracks or other areas of application. Acids and corrosives are not permitted.
- (B) Provide entry ports along the crack at intervals determined by the Contractor to ensure full penetration of the crack.
- (C) Apply surface seal material to the face of the crack between the entry ports. For through cracks, apply surface seal to both faces.
- (D) Allow enough time for the surface seal material to gain adequate strength before proceeding with the injection.
- (E) Perform an air pressure check of the surface seal to ensure the system is airtight prior to proceeding with the injection.

### **EPOXY INJECTION**

Before epoxy adhesive injection occurs, the Contractor shall test discharge one pint of epoxy to calibrate the equipment and to demonstrate that the workmen and equipment are working properly.

Follow approved preparation and installation procedures submitted by the Contractor. It is the Contractor's responsibility to achieve full penetration of cracks being injected.

Perform epoxy adhesive injection continuously until cracks are completely filled. Pressure shall be maintained until complete refusal of material is achieved. Any stoppage of injection for more than 15 minutes shall result in the injection equipment being cleaned, at no additional cost to the Department, before resuming injection.

If port to port travel of epoxy adhesive is not indicated, or the surface seal and/or ports become dislodged, immediately stop the work and notify the Engineer.

### **TESTING**

The Contractor shall core 3" diameter by 6" deep samples of the cured epoxy to verify the cracks have been completely filled with epoxy. When coring, care shall be taken to avoid existing steel reinforcement, where possible. Injection will not proceed beyond the initial 50 feet until three (3) cores have been submitted to, and approved by, the Engineer. If the epoxy does not penetrate a minimum of 6" or the full depth of the crack, whichever is less, the repair will be rejected, and the contractor shall follow their proposed repair procedure that has been approved by the Engineer. The presence of the technical representative will be required when repairs begin.

The Engineer will take possession of the cores from the repaired concrete for compressive strength testing. If the failure plane is located at the repaired crack, a minimum compressive strength of 3,000 psi is required of these cores. The cost of coring is incidental to the pay item for epoxy injection. If the core fails, the contractor will be required to take corrective action before proceeding and another 50' test section will be required.



15BPR.130.3

**BP-69**

Chatham and Moore Counties

After the contractor demonstrates acceptable repairs, cores will be taken at a rate of one per 100 linear feet of repair until completion of the work or unacceptable cores are encountered.

**FINISHING**

When cracks are completely filled, allow the epoxy adhesive to cure for sufficient time to allow the removal of the surface seal without any draining or runback of epoxy material from the cracks.

Fill all cored holes with Type 3 grout in accordance with Section 1003 of the *Standard Specifications*.

Remove the surface seal material and injection adhesive runs or spills from concrete surfaces.

Finish the face of the crack and all core holes flush to the adjacent concrete, removing any indentations or protrusions caused by the placement of entry ports or grout placement.

**MEASUREMENT AND PAYMENT**

*Epoxy Resin Injection* will be paid at the contract unit price per linear foot. For full depth cracks, payment will be made for one side only. Such payment will be full compensation for all materials, tools, equipment, labor, coring and for all incidentals necessary to complete the work.

Payment will be made under:

<b>Pay Item</b>	<b>Pay Unit</b>
Epoxy Resin Injection	Linear Foot

**DRIFT REMOVAL****(SPECIAL)****DESCRIPTION**

The Contractor shall remove all drift and debris located around the bridge, as well as located in or around the water as per the plans or as directed by the Engineer.

The Contractor shall notify the Engineer of any discoveries, such as scour holes or bridge damage, as soon as they are discovered.

The Contractor shall contain all drift and debris within the work area, as not to allow them to float downstream of the work area.

The Contractor shall removal all drift and debris materials from the project site and properly dispose of them.

The Contractor is responsible for drift and debris removal for the duration of the project.

The Contractor shall access the drift from the bridge deck, and may be assisted by in-water boats, but no access to the drift will be allowed from the stream banks.

15BPR.130.3

**BP-70**

Chatham and Moore Counties

**SUBMITTALS**

The Contractor shall submit to the Engineer for approval the proposed method(s) for drift and debris removal prior to starting work.

**BASIS OF PAYMENT**

*Drift Removal* will be measured and paid for at the contract lump sum bid price and will be full compensation for furnishing all material, labor, tools, and equipment necessary for removal and disposal as accepted.

Payment will be made under:

<b>Pay Item</b>	<b>Pay Unit</b>
Drift Removal	Lump Sum

**ZONE PAINTING OF EXISTING STRUCTURE****(SPECIAL)****DESCRIPTION**

This work shall consist of furnishing all labor, equipment, and materials necessary to remove and replace the existing paint coating and/ or to overcoat the existing paint coating on structural steel of the existing bridge or surrounding area as indicated in the contract documents.

This project may involve toxic metals such as arsenic, lead, cadmium, and hexavalent chromium. It is the contractor's responsibility to test for toxic metals and, if found, comply with all applicable OSHA regulations, which may include medical testing.

Work includes: design and construction of a containment enclosure; removal, containment, and disposal of the existing paint system; preparation of the surface to be painted; application of the new paint system; and any incidentals necessary to complete the project as specified and shown on the plans.

**TWELVE-MONTH OBSERVATION PERIOD**

The Contractor maintains responsibility for the coating system for a 12-month observation period beginning upon the satisfactory completion of all the work required in the plans or as directed by the Engineer. The Contractor shall guarantee the coating system under the payment and performance bond (refer to Article 109-10 of the *Standard Specifications*). To complete successfully the observation period, the coating system shall meet the following requirements after 12 months service:

- (A) No visible rust, contamination or application defect is observed in any coated area.
- (B) Painted surfaces have a uniform color and gloss.

(C) Painted surfaces have an adhesion that meets an ASTM D3359, 3A rating. Final acceptance is made only after the paint system meets the above requirements.

### **SUBMITTALS**

Submit all of the following to the Engineer for review and approval before scheduling the pre-construction meeting. Allow at least two (2) weeks for the review process.

- (A) The existing paint systems include toxic substances such as red lead oxide, which are considered hazardous if improperly removed. The contractor shall be currently Society for Protective Coatings (SSPC) Quality Program (QP) 2, Category A certified, and have successfully completed lead paint removal and field painting on similar structures within 18 months prior to this bid. Lead abatement work completed within the 18 month period shall have been completed in accordance with contract specifications, free of citation from safety or environmental agencies. Lead abatement work shall include, but not be limited to: abrasive blasting; waste handling, storage and disposal; worker safety during lead abatement activities (fall protection, personal protective equipment (PPE), etc.); and containment. This requirement is in addition to the contractor pre-qualification requirements covered by Article 102-2 of the *Standard Specifications*.

The apparent low bidder shall submit a list of projects for which QP 2 work was performed within the last 18 months including owner contact information and submit to the Engineer a "Lead Abatement Affidavit". This form may be downloaded from: <https://www.ncdot.gov/initiatives-policies/Transportation/bridges/Documents/leadabatementaffidavit.pdf>

- (B) Work schedule which shall be kept up to date, with a copy of the revised schedule being provided to the Engineer in a timely manner.
- (C) Containment system plans and design calculations in accordance with SSPC Guide 6, Class 2A and other project requirements, signed and sealed by a Professional Engineer licensed by the State of North Carolina.
- (D) Bridge wash water sampling and disposal plan.
- (E) Subcontractor identification.
- (F) Lighting plan for night work in accordance with Section 1413 of the *Standard Specifications*.
- (G) Traffic control plan with NCDOT certified supervisors, flaggers and traffic control devices.
- (H) Health and safety plan addressing at least the required topics as specified by the SSPC QP 1 and QP 2 program and including hazard communication, respiratory health, emergency procedures, and local hospital and treatment facilities with directions and phone numbers, disciplinary criteria for workers who violate the plan and accident investigation. The plan shall address the following: hazardous materials, personal protective equipment, general health and safety, occupational health and environmental controls, fire protection and prevention, signs signals, and barricades, materials handling, storage, use, and disposal, hand and power tools, welding and cutting, electrical, scaffolds, fall protection, cranes, derricks, hoists, elevators, and conveyors, ladders, toxic and hazardous substances, airless injection and high pressure water jet (HPWJ).

- (I) Provide the Engineer a letter of certification that all employees performing work on the project have blood lead levels that are below the Occupational Safety and Health Administration (OSHA) action level.
- (J) Provide the Engineer with Competent Person qualifications and summary of work experience.
- (K) Environmental Compliance Plan.
- (L) Quality Control Plan (Project Specific) with quality control qualifications and summary of work experience.
- (M) Bridge and Public Protection Plan (Overspray, Utilities, etc. - Project/Task Specific).
- (N) Abrasive Blast Media:
  - (1) Product Data Sheet.
  - (2) Blast Media Test Reports in accordance with Article 1080-12 of the *Standard Specification*.
- (O) Coating Material:
  - (1) NCDOT HICAMS Test Reports (testing performed by NCDOT Materials and Tests Unit).
  - (2) Product Data Sheets.
  - (3) Material Safety Data Sheets.
  - (4) Product Specific Repair Procedures.
  - (5) Acceptance letters from paint manufacturer's for work practices that conflict with special provisions and/or paint manufactures product data sheets.
  - (6)

**PRE-CONSTRUCTION MEETING**

Submittals shall be reviewed and approved by the Engineer prior to scheduling the pre-construction meeting. Allow no less than two (2) weeks for a review process. When requesting a pre-construction meeting, contact the Engineer at least seven (7) working days in advance of the desired pre-construction date. The contractor's project supervisor, Competent Person, quality control personnel and certified traffic control supervisor shall be in attendance at the pre-construction meeting in order for the Contractor and NCDOT team to establish responsibilities for various personnel during project duration and to establish realistic timeframes for problem escalation.

**CONTAINMENT SYSTEM**

Prior to performing any construction or painting operations on the structure, the Contractor shall furnish the Engineer with plans and design calculations for a sufficiently designed containment system, which will provide access for any repairs on structural steel members, cleaning and surface preparations for structural steel members, and coating operations for structural steel members of the bridge. The containment system shall not be installed, and no work shall begin, until the Engineer has reviewed and approved, in writing, the submitted containment system plans and design calculations. Containment system plans and design calculations shall be prepared, sealed, and signed by a Professional Engineer licensed by the State of North Carolina. Allow a minimum of two (2) weeks for review of the containment plans and calculations.

The containment system shall meet or exceed the requirements of Class 2A containment in

accordance with SSPC Guide 6. The Contractor shall determine the required capacity of the containment system, which, at a minimum, shall include loads due to wind, repair materials and repair operations, equipment, and tools; however, the capacity shall not be less than that required by Federal or State regulations. Design steel members to meet the requirements of the *American Institute of Steel Construction Manual*. Design timber members in accordance with the *National Design Specification for Stress-Grade Lumber and Its Fastenings* of the National Forest Products Association. The containment system shall be constructed of materials capable of withstanding damage from any of the work required on this project and shall provide a two (2) hour resistance to fire.

In the containment system plans, describe how debris is contained and collected. Describe the type of tarpaulin, bracing materials, and the maximum designed wind load. Design wind loads shall be in accordance with the Falsework and Formwork special provision. Describe the dust collection system and how a negative pressure of 0.03 inches of water column is maintained inside the enclosure, while blasting operations are being conducted. Describe how the airflow inside the containment structure is designed to meet all applicable OSHA Standards. Describe how water run-off from rain will be routed by or through the enclosure. Describe how wash water will be contained and paint chips separated. Describe what physical containment will be provided during painting application to protect the public and areas not to be painted.

Drilling holes in the superstructure for the purpose of attaching the containment system is prohibited.

The Contractor will be responsible for certifying the containment system has been constructed in accordance with the approved plans.

The containment system shall be cleaned after each workday.

Upon completion of work, remove all anchorages in the substructure and repair the substructure at no additional cost to the Department.

Protect non-metallic parts of bearings from blasting and painting (i.e.: Pot Bearings, Elastomeric Pads, and Disc Bearings).

#### **WASH WATER SAMPLING AND DISPOSAL PLAN**

All wash water shall be collected and sampled prior to disposal. Representative sampling and testing methodology shall conform to North Carolina Administrative Code 15A NCAC 02B.0103, "Analytical Procedures". Wash water shall be tested for pollutants listed in 15A NCAC 02B.0211(3), 15A NCAC 02T.0505(b)(1) and 15A NCAC 2T.0905(h). Depending on the test results, wash water disposal methods shall be described in the disposal plan. Wash water shall be disposed of in accordance with all current Federal and State regulations. See link for NCDOT Guidelines for Managing Bridge Wash Water:

<https://www.ncdot.gov/initiatives-policies/Transportation/bridges/Documents/WashWater.pdf>

#### **WASTE HANDLING OF PAINT AND ABRASIVES**

Comply with all Federal, State, and local regulations. Failure to comply with the regulations

could result in fines and loss of qualified status with NCDOT.

Comply with the Resource Conservation and Recovery Act (RCRA - 40 CFR 261 - 265) and the Occupational Safety and Health Act (OSHA - 29 CFR 1910 - 1926) regulations for employee training, and for the handling, storage, labeling, recordkeeping, reporting, inspections and disposal of all hazardous waste generated during paint removal.

A summary of Generator Requirements is available at the above NCDOT web link, which cites the specific regulations for each Generator category. Quantities of waste by weight and dates of waste generation shall be recorded. Waste stored at the project site shall be properly labeled. All waste, hazardous or non-hazardous, requires numbered shipping manifests.

The North Carolina Department of Environmental Quality (NCDEQ) have adopted RCRA as the North Carolina Hazardous Waste Management Rules and are responsible for enforcement. The *Hazardous Waste Generator Compliance Manual* is published by the Compliance Branch of the Division of Waste Management of NCDEQ, and can be found at:

<https://files.nc.gov/ncdeq/Waste%20Management/DWM/HW/Compliance/Generator%20Compliance%20Manual.pdf>

Immediately after award of the contract, arrange for waste containers, sampling, testing, transportation, and disposal of all waste. No work shall begin until the Contractor furnishes the Engineer with a written waste disposal plan. Any alternative method for handling waste shall be pre-approved by the Engineer. Use an approved waste management company from the following link: <https://www.ebs.nc.gov/VendorDirectory/results.html?sap-params=cD0xJTIwJmN1cnJlbnRfc2VhemNoX3BhZ2U9d2Mmc2VsZWN0aW9uX2Zpcm1fbmFtZT0mc2VsZWN0aW9uX2NlcnQ9JnNlbGVjdGlvb19maXJtdHlwZT0meXNjX2Zpcm10eXBIPSZzZWxlY3Rpb25fd29ya2xvY2F0aW9uPSZ5c2Nfd29ya2xvY2F0aW9uPSZzZWxlY3Rpb25fYWRkcN0YXRIPSZzZWxlY3Rpb25fYWRkcmNvdW50eT0meXNjX2FkZHIjb3VudHk9JnNlbGVjdGlvb193a2NvZGU9MDAzMDQwJnlzY193a2NvZGU9MDAzMDQwJTIwQ09OVEFNSU5BVEVEJTIwTUFURVJQUxTJTIwUkVNT1ZBTCZzZWxlY3Rpb25fZGlzYz0meXNjX2Rpc2M9JnNlbGVjdGlvb19uYWljcz0meXNjX25haWNzPSZzZWxlY3Rpb25fY3R5cGU9MA%3d%3d>

All removed paint and spent abrasive media shall be tested for lead following the SW-846 Toxicity Characteristic Leaching Procedure (TCLP) Method 1311 Extraction, as required in 40 CFR 261, Appendix 11, to determine whether it shall be disposed of as hazardous waste. Furnish the Engineer

certified test reports showing TCLP results of the paint chips stored on site, with disposal in

accordance with “Flowchart on Lead Waste Identification and Disposal” at:  
<https://ncdenr.s3.amazonaws.com/s3fs-public/document-library/Lead%20Disposal.pdf>

All sampling shall be done in presence of the Engineer’s representative.

The Competent Person shall obtain composite samples from each barrel of the wash water and waste generated by collecting two or more portions taken at regularly spaced intervals during accumulation. Composite the portions into one sample for testing purposes. Acquire samples after 10% or before 90% of the barrel has accumulated. The intent is to provide samples that are representative of widely separated portions, but not the beginning and end of wash water or waste accumulation.

Perform sampling by passing a receptacle completely through the discharge stream or by completely diverting the discharge into a sample container. If discharge of the wash water or waste is too rapid to divert the complete discharge stream, discharge into a container or transportation unit sufficiently large to accommodate the flow and then accomplish the sampling in the same manner as described above.

Comply with the NCDEQ *Hazardous Waste Compliance Generator Manual*. Record quantities of waste by weight and dates of waste generation. Until test results are received, store all waste, and label as “NCDOT Bridge Paint Removal Waste - Pending Analysis” and include the date generated and contact information for the Engineer. Store waste containers in an enclosed, sealed, and secured storage container protected from traffic from all directions. Obtain approval for the protection plan for these containers from the Engineer. If adequate protection cannot be obtained by use of existing guardrail, provide the necessary supplies and equipment to maintain adequate protection. Once test results are received and characterized, label waste as either “Hazardous Waste - Pending Disposal” or “Paint Waste- Pending Disposal”.

Once the waste has been collected, and the quantities determined, prepare the appropriate shipping documents and manifests and present them to the Engineer. The Engineer will verify the type and quantity of waste and obtain a Provisional Environmental Protection Agency (EPA) ID number from:

Melodi Deaver  
Division of Waste Management/Hazardous  
Waste Section North Carolina Department of  
Environmental Quality 1646 Mail Service Center  
Raleigh, NC 27699  
Phone: (919) 707-8204, Email: [melodi.deaver@ncdenr.gov](mailto:melodi.deaver@ncdenr.gov)

At the time of shipping, the Engineer will sign, date, and add the ID number in the appropriate section on the manifest. The maximum on-site storage time for collected waste shall be 90 calendar days. All waste whether hazardous or non-hazardous will require numbered shipping manifests. The cost for waste disposal (including lab and Provisional EPA ID number) is included in the bid price for this contract. Note NC Hazardous Waste Management Rules (15A NCAC 13A) for more information. Provisional EPA ID numbers may be obtained at:

<https://deq.nc.gov/about/divisions/waste-management/hw/provisional-notification>

Testing labs shall be certified in accordance with North Carolina State Laboratory Public Health Environmental Sciences. List of certified laboratories may be obtained at:

<https://slphreporting.ncpublichealth.com/Certification/CertifiedLaboratory.asp>

All test results shall be documented on the lab analysis as follows:

(A) For leachable lead:

(1) Soils/Solid/Liquid- EPA 1311/200.7/6010

Area sampling will be performed for the first two (2) days at each bridge location. The area sample will be located within five (5) feet of the containment and where the highest probability of leakage will occur (access door, etc.). Results from the area sampling will be given to the Engineer within 72 hours of sampling (excluding weekends). If the results of the samples exceed  $20 \mu\text{g}/\text{m}^3$  corrective measures shall be taken and monitoring shall be continued until two (2) consecutive sample results are less than  $20 \mu\text{g}/\text{m}^3$ .

Time Weighted Average (TWA) may suspend the work if there are visible emissions outside the containment enclosure or pump monitoring results exceeding the level of  $30 \mu\text{g}/\text{m}^3$ .



Where schools, housing and/or buildings are within 500 feet of the containment, the Contractor shall perform initial Total Suspended Monitoring (TSP) Lead monitoring for the first ten (10) days of the project during abrasive blasting, vacuuming and containment removal. Additional monitoring will be required during abrasive blasting two (2) days per month thereafter. Results of the TSP monitoring at any location shall not exceed  $1.5 \mu\text{g}/\text{m}^3$ .

#### **EQUIPMENT MOBILIZATION**

The equipment used in any travel lanes and paved shoulder shall be mobile equipment on wheels that has the ability to move on/off the roadway in less than 30 minutes. All work conducted in travel lanes shall be from truck or trailer supported platforms and all equipment shall be self-propelled or attached to a tow vehicle at all times.

#### **QUALITY CONTROL INSPECTOR**

Provide a quality control (QC) inspector in accordance with the SSPC QP guidelines to ensure that all processes, preparation, blasting and coating application are in accordance with the requirements of the contract. The inspector shall have written authority to perform QC duties to include continuous improvement of all QC internal procedures. The presence of the engineer or inspector at the work site shall in no way lessen the contractor's responsibility for conformity with the contract.

#### **QUALITY ASSURANCE INSPECTOR**

The quality assurance inspector which may be a Department employee or a designated representative of the Department shall observe, document, assess, and report that the Contractor is complying with all of the requirements of the contract. Inspectors employed by the Department are authorized to inspect all work performed and materials furnished. Such inspection may extend to all or any part of the work and to the preparation, fabrication, or manufacture of the materials to be used. The inspector is not authorized to alter or waive the requirements of the contract. Each stage in preparing the structure to be coated which includes but not limited to washing, blasting, coating testing and inspection shall be inspected and approved by the Engineer or an authorized representative.

#### **SUBLETTING OF CONTRACT**

Only contractors certified to meet SSPC QP 2, Category A, and have successfully completed lead paint removal and field painting on all similar structures within 18 months prior to this bid are qualified for this work. Work is only sublet by approval of the Engineer.

#### **LIMITS OF ZONE PAINTING**

Removal of existing paint system, required surface preparation, and application of new painting system shall extend to the limits indicated on the project plans. Additionally, the new paint system shall overcoat the existing paint system and be blended for a dimension of 6" to 12" beyond the limits of the existing paint removal. The existing paint system that remains in the

overcoat area shall be properly prepared for required adhesion of the new paint system.

### **PREPARATION OF SURFACES**

Before any other surface preparation is conducted, all surfaces shall be power washed to remove dust, salts, dirt, and other contaminants. All wash water shall be contained, collected, and tested in accordance with the requirements of NCDOT Guidelines for Managing Bridge Wash Water. Obtain approval of the Engineer and allow all cleaned surfaces to dry to the touch and without standing water before beginning surface preparation or painting activities.

Surface preparation is done with materials meeting Article 1080-12 of the *Standard Specifications*. No silica sand or other silica materials are permitted for use. The profile shall be between 1.0 and 3.0 mils when measured on a smooth steel surface. Conduct and document at least two (2) tests per beam/girder and two (2) tests per span of diaphragms/cross bracing.

Spread tarpaulins over all pavements and surfaces underneath equipment used for abrasive blasting as well as equipment and containers used to collect abrasive media. This requirement will be enforced during activity and inactivity of equipment.

Before the Contractor departs from the work site at the end of the workday, collect all debris generated during surface preparation and all dust collector hoses, tarps or other appurtenances containing blasting residue in approved containers.

Clean a 3" x 3" area at each structure to demonstrate the specified finish, and the inspector will preserve this area by covering it with tape, plastic or some other suitable means so that it can be retained as the Dry Film Thickness (DFT) gauge adjustment standard. An acceptable alternative is for the Contractor to provide a steel plate with similar properties and geometry as the substrate to be measured.

The contractor and or quality assurance representative shall notify the Engineer of any area of corroded steel that has lost more than 50% of its original thickness.

All parts of the bridges not to be painted and the travelling public shall be protected from overspray. Submit a plan to protect all parts of bridge that are not required to be painted and a plan to protect the traveling public and surrounding environment while applying all coats of paint to a structure.

Ensure that chloride levels on the surfaces are  $7 \mu\text{g}/\text{cm}^2$  or lower using an acceptable sample method in accordance with SSPC Guide 15. The frequency of testing shall be two (2) tests per span after all surface

preparation has been completed and immediately prior to painting. Select test areas representing the greatest amount of corrosion in the span as determined by the Engineers' representative. Additional testing may be required if significant amounts of chloride are detected.

All weld splatter, slag or other surface defects resulting in a raised surface above the final paint

layer shall be removed prior to application of primer coat.

#### **PAINTING OF STEEL**

Paint System 1, as specified in these special provisions and Article 442-8 of the *Standard Specifications*, is to be used for this work. System 1 is an inorganic zinc primer, two coats acrylic paint, and one stripe coat of acrylic paint over blast-cleaned surfaces in accordance with SSPC-SP-10 (Near White Blast). Perform all mixing operations over an impervious surface with provisions to prevent runoff to grade of any spilled material. The contractor is responsible for reporting quantities of thinner purchased as well the amounts used. No container with thinner shall be left uncovered, when not in use.

Apply 2" stripe coat, by brush or roller only, to all exposed edges of steel including fasteners before applying the finish coat. Locate the edge or corner in the approximate center of the paint stripe.

Painting shall cover the area where existing paint has been removed, and paint shall be blended for a dimension of 6" to 12" onto the existing paint system.

Any area where newly applied paint fails to meet the specifications shall be repaired or replaced by the Contractor, at no additional cost to the Department. The Engineer approves all repair processes before the repair is made. Repaired areas shall meet the *Standard Specifications*. The Contractor applies an additional finish coat of paint to areas where the tape adhesion test is conducted.

#### **MATERIALS**

Only paint suppliers that have a NCDOT qualified inorganic zinc primer may furnish paints for this project. All paints applied to a structure shall be from the same supplier. Before any paints are applied the Contractor shall provide the Engineer a manufacturer's certification that each batch of paint meets the requirements of the applicable Section 1080 of the *Standard Specifications*.

Color of the paint shall match that of the existing paint on the structure steel.

The inspector randomly collects a one pint sample of each paint product used on the project. Additional samples may be collected as needed to verify compliance to the specifications.

Do not expose paint materials to rain, excessive condensation, long periods of direct sunlight, or temperatures above 110°F or below 40°F. In addition, the Contractor shall place a device that records the high, low, and current temperatures inside the storage location. Follow the manufacturer's storage requirements if more restrictive than the above requirements.

#### **INSPECTION**

Surface Preparation for System 1 shall be in accordance with SSPC SP-10. Any area(s) not meeting the requirements of SSPC SP-10 shall be remediated prior to application of coating. Surface inspection is

15BPR.130.3

**BP-80**

Chatham and Moore Counties

considered ready for inspection when all blast abrasive, residue and dust is removed from surfaces to be coated.

**(A) Quality Assurance Inspection**

The Contractor furnishes all necessary OSHA approved apparatus such as ladders, scaffolds and platforms as required for the inspector to have reasonable and safe access to all parts of the work. The contractor illuminates the surfaces to be inspected to a minimum of 50-foot candles of light. All access points shall be illuminated to a minimum of 20-foot candles of light.

NCDOT reserves the right for ongoing Quality Assurance (QA) inspection to include but not limited to surface contamination testing, adhesion pull testing, and DFT readings as necessary to assure quality.

Inform the Engineer and the Division Safety Engineer of all scheduled and unannounced inspections from SSPC, OSHA, EPA and/or others that come on site. Furnish the Engineer a copy of all inspection reports except for reports performed by a third party and or consultant on behalf of the Contractor.

**(B) Inspection Instruments**

At a minimum, furnish the following calibrated instruments and conduct the following quality control tests:

- (1) Sling Psychrometer - ASTM E337 - bulb type
- (2) Surface Temperature Thermometer
- (3) Wind Speed Indicator
- (4) Tape Profile Tester - ASTM D4417 Method C
- (5) Surface Condition Standards - SSPC VIS-1 and VIS-3
- (6) Wet Film Thickness Gage - ASTM D4414
- (7) Dry Film Thickness Gage - SSPC-PA2 Modified
- (8) Solvent Rub Test Kit - ASTM D4752
- (9) Adhesion Test Kit - ASTM D3359 Method A (Tape Test)
- (10) Adhesion Pull test - ASTM D4541
- (11) Surface Contamination Analysis Kit or (Chloride Level Test Kit) SSPC Technology Guide 15

**(C) Quality Control**

Maintain a daily quality control record in accordance with Subarticle 442-12(D) of the *Standard Specifications* and make such records available at the job site for review by the inspector and submit to the Engineer as directed. In addition to the information required on Form M&T-610, submit all Dry Film Thickness (DFT) readings on a form equivalent to Form M&T-611. These forms can be found at:

<https://connect.ncdot.gov/resources/Materials/Pages/Materials-Manual-by-Material.aspx?Order=MM-03-02>

- (1) Measure DFT at each spot on the attached diagram and at the required number of locations as specified below:

15BPR.130.3

## **BP-81**

Chatham and Moore Counties

- (a) For span members less than 45 feet; three (3) random locations along each girder in each span.
- (b) For span members greater than 45 feet; add one additional location for each additional ten (10) feet in span length.

DFT measurements for the prime coat shall not be taken for record until the zinc primer has cured in accordance with ASTM D4752 (MEK Rub Test) with no less than a four (4) resistance rating.

Stiffeners and other attachments to beams and or plate girders shall be measured at no less than five (5) random spots per span. Also, dry film thickness is measured at no less than six (6) random spots per span on diaphragms/cross frames.

Each spot is an average of three (3) to five (5) individual gage readings as defined in SSPC PA-2. No spot average shall be less than 80% of minimum DFT for each layer applied; this does not apply to stripe coat application. Spot readings that are non-conforming shall be re-assessed by performing additional spot measurements not to exceed one-foot intervals on both sides of the low areas until acceptable spot averages are obtained. These non-conforming areas shall be corrected by the Contractor prior to applying successive coats.

15BPR.130.3

**BP-82**

Chatham and Moore Counties

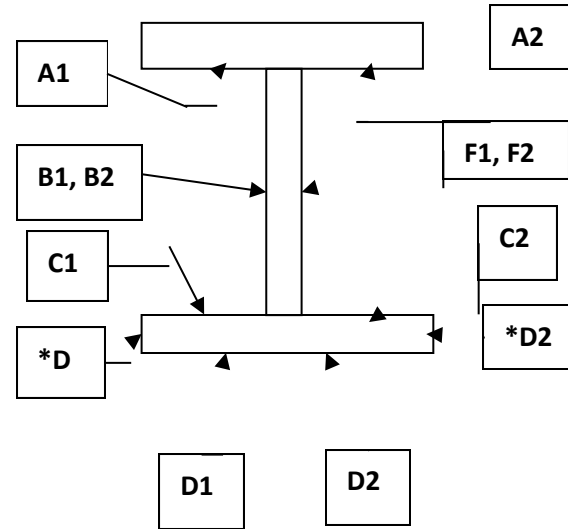
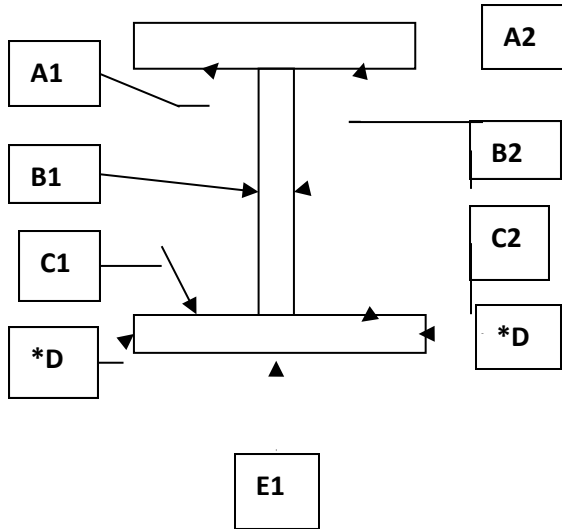
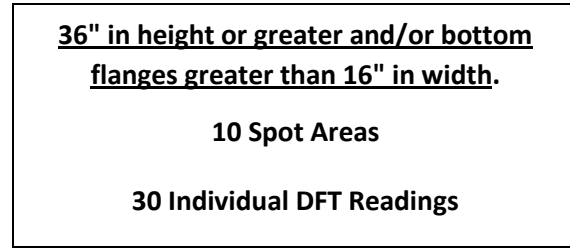
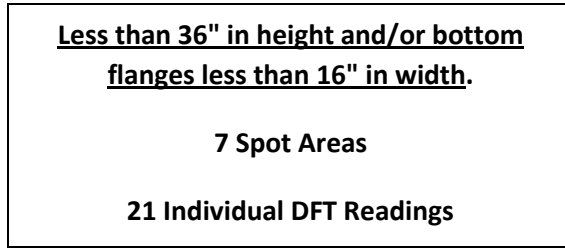

**\*D areas are only included when flange thickness is one inch (1") or greater.**

**\*D areas are only included when flange thickness is one inch (1") or greater.**

- (2) Two (2) random adhesion tests (1 test = 3 dollies) per span are conducted on interior surfaces in accordance with ASTM D4541 (Adhesion Pull Test) after the prime coat has been properly cured in accordance with ASTM D4752 (MEK Rub Test) with no less than a four (4) resistance rating, and will be touched up by the Contractor. The required minimum average adhesion is 400 psi.
- (3) Cure of the intermediate and stripe coats shall be accessed by using the thumb test in accordance with ASTM D1640 (Curing Formation Test) prior to the application of any successive layers of paint.
- (4) One random Cut Tape adhesion test per span is conducted in accordance with ASTM D3359 (X-Cut Tape Test) on interior surface after the finish coat is cured. Repair areas shall be properly tapered and touched up by the Contractor.

15BPR.130.3

**BP-83**

Chatham and Moore Counties

**SAFETY AND ENVIRONMENTAL COMPLIANCE PLANS**

Personnel access boundaries are delineated for each work site using signs, tape, cones, or other approved means. Submit copies of safety and environmental compliance plans that comply with SSPC QP 2 Certification requirements.

**HEALTH AND SAFETY RESPONSIBILITIES**

This project may involve toxic metals such as arsenic, lead, cadmium and hexavalent chromium. It is the contractor's responsibility to test for toxic metals and if found, comply with the OSHA regulations, which may include medical testing.

Ensure a "Competent Person" as defined in OSHA 29 CFR 1926.62; one who is capable of identifying existing and predictable hazards in the surroundings or working conditions which are unsanitary, hazardous, or dangerous to employees, and who has authorization to take prompt corrective measures to eliminate them; is on site during all surface preparation activities and monitors the effectiveness of containment, dust collection systems and waste sampling. Before any work begins, provide a written summary of the Competent Person's safety training.

Comply with Subarticle 442-14(B) of the *Standard Specifications*.

Comply with Subarticle 442-14(D) of the *Standard Specifications*. Ensure employee blood sampling test results are less than 50 micrograms per deciliter. Remove employees with a blood sampling test of 50 or more micrograms per deciliter from work activities involving any lead exposure.

An employee who has been removed with a blood level of 50 micrograms per deciliter or more shall have two (2) consecutive blood sampling tests spaced one week apart indicating that the employee's blood lead level is at or below 40 micrograms per deciliter before returning to work activities involving any lead exposure.

All OSHA recordable accidents that occur during the project duration are to be reported to the Engineer within twenty-four (24) hours of occurrence. In addition, for accidents that involve civilians or property damage that occurs within the work zone the Division Safety Engineer shall be notified immediately.

Prior to blasting operations, the Contractor shall have an operational OSHA approved hand wash station at each bridge location and a decontamination trailer at each bridge or between bridges unless the work is on the roadway, or the Contractor shall show reason why it is not feasible to do so and provide an alternative site as approved by the Engineer. The Contractor shall assure that all employees whose airborne exposure to lead is above the Permissible Exposure Limit (PEL) shall shower at the end of their work shift.

**STORAGE OF PAINT AND EQUIPMENT**

Provide a location for materials, equipment, and waste storage. Spread tarpaulins over all pavements and surfaces underneath equipment used for abrasive recycling and other waste handling equipment or containers. All land and or lease agreements that involve private property shall disclose to the property owner that heavy metals may be present on the Contractor's equipment. Prior to storing the Contractor's equipment on private property, provide a notarized written consent signed by the land owner received by the Engineer at least forty-eight (48) hours before using property. All storage of paint, solvents, and other materials applied to structures shall be stored in accordance with Subarticle 442-9(C) of the

15BPR.130

BP-84

Chatham and Moore Counties

*Standard Specifications* or the manufacturers' requirements. The more restrictive requirements will apply.

#### UTILITIES

Protect all utility lines or mains that may be supported on, under, or adjacent to bridge work sites from damage and paint overspray.

#### MEASUREMENT AND PAYMENT

The cost of inspection, surface preparation, and repainting the existing structure is included in the lump sum price bid for *Zone Painting of Existing Structure*. This price is full compensation for furnishing all inspection equipment, all paint, cleaning abrasives, cleaning solvents and all other materials; preparing and cleaning surfaces to be painted; applying paint in the field; protecting work area, traffic and property; and furnishing blast cleaning equipment, paint spraying equipment, brushes, rollers, any other hand or power tools and any other equipment; and a containment enclosure.

*Pollution Control* will be paid at the contract lump sum price which will be full compensation for all collection, handling, storage, air monitoring, and disposal of debris and wash water, all personal protective equipment, and all personal hygiene requirements, and all equipment, material and labor necessary for the daily collection of the blast debris into specified containers; and any measures necessary to ensure conformance to all safety and environmental regulations as directed by the Engineer.

*Painting Containment for Zone Painting* will be paid at the lump sum contract price and will be full compensation for the design, materials, installation, maintenance, and removal of the containment system.

Payment will be made under:

<b>Pay Item</b>	<b>Pay Unit</b>
Zone Painting of Existing Structure	Lump Sum
Pollution Control	Lump Sum
Painting Containment for Zone Painting	Lump Sum

#### SCOPE OF WORK

**Bridge #180007:** This bridge was built in 1998 and carries US 1 SBL over Deep River. The superstructure consists of 10 prestressed concrete girder spans, 1-129'-8" span with 5 lines of 60" plate girders @ 8'-6" spacing with steel diaphragms, and 1-40'-0" span with 6 lines of of haunched 30" rolled beams @ 8'-6" spacing with steel diaphragms. The bridge has an out-to-out deck width of 41'-1". The ends of the steel beams shall be painted a length of 5' from each end and the bolted field splices shall be painted 3' from the center of the splice each direction. The existing paint system is unknown, and the estimated area to be cleaned and painted is **1,600** sq. ft.



15BPR.130

BP-85

Chatham and Moore Counties

**Bridge #180477:** This bridge was built in 1998 and carries US 1 NBL over Deep River. The superstructure consists of 10 prestressed concrete girder spans, 1-129'-8" span with 6 lines of 60" plate girders @ 8'-5" spacing with steel diaphragms, and 1-40'-0" span with 6 lines of of haunched 30" rolled beams @ 8'-5" spacing with steel diaphragms. The bridge has an out-to-out deck width of 41'-1". The ends of the steel beams shall be painted a length of 5' from each end and the bolted field splices shall be painted 3' from the center of the splice each direction. The existing paint system is unknown, and the estimated area to be cleaned and painted is **1,900** sq. ft.

**REPAIRS TO PRESTRESSED CONCRETE GIRDERS** (SPECIAL)

**DESCRIPTION**

Work includes removal of concrete in spalled and/ or delaminated areas of the existing prestressed concrete girders, in reasonably close conformity with the lines, depth, and details shown on the plans, described herein, and as established by the Engineer. This work also includes straightening, cleaning, and replacement of reinforcing steel; repair and retensioning of damaged prestressing strand(s); application of High Ratio Co-Polymerized Calcium Sulfonate (HRCSA) corrosion penetrant; doweling/ adhesively anchoring new reinforcing steel or studs; removing all loose materials; removing and disposing of debris; formwork; applying repair material; and protecting adjacent areas of the bridge and environment from work operations. The repair material shall be one of the materials described below, unless otherwise noted in the plans or special provisions.

At the time of preparation of these plans, it was not anticipated that splicing of prestressing strands would be required. However, it may be determined in the field that splicing of prestressing strands, or other work will be necessary to properly complete the intended bridge preservation/ rehabilitation work. The Contractor shall be prepared to perform such work in a timely manner, as determined in the field. Such work shall be considered Extra Work and shall be addressed as per Article 104-7 of the Standard Specifications. Project Special Provisions that outline requirements for these potential additional work items have been provided in project documents, but no quantities have been listed.

Actual pay items, quantities, and costs will be established, as required, if Extra Work is encountered.

The location and extent of repairs shown on the plans are general in nature. The Engineer shall determine the extent of removal in the field based on an evaluation of the condition of the exposed surfaces.

The Contractor shall coordinate removal operations with the Engineer. No more than 30% of the bearing area under a beam shall be removed without a temporary support system and approval from the Engineer.

Any portion of the structure that is damaged from construction operations shall be repaired to the Engineer's satisfaction, at no extra cost to the Department.

**SUBMITTALS**

Submit all of the following to the Engineer for review and approval before scheduling the pre-construction meeting. Allow 40 calendar days for review and approval, or acceptance, of working drawings, from the date they are received, until they are returned by the Engineer.

- (A) HRCSA (High Ratio Co-Polymerized Calcium Sulfonate) Penetrant
- (B) Polymer Modified Concrete Repair Material
- (C) Epoxy Mortar Repair Material
- (D) Temporary Work Platform
- (E) Strand Splice Device

#### **GENERAL SURFACE PREPARATION**

Prior to starting the repair operation, confirm and delineate all surfaces and areas assumed to be deteriorated by visually examining and sounding the concrete surface with a hammer (14 ounce or larger) or other approved method. The Engineer is the sole judge in determining the limits of deterioration.

Remove surface concrete to verify that a ½” sawcut depth will not damage existing reinforcing steel or prestressing strand. If confirmed, introduce a shallow saw cut a minimum ½” in depth around the repair area, at right angles to the concrete surface. Within the limits of the sawcut, remove all concrete to a minimum depth of ½”. Remove all unsound concrete in the repair area, and where the bond between existing concrete and reinforcing steel has been compromised, or where more than half of the diameter of the reinforcing steel is exposed, remove concrete 1 inch behind the reinforcing steel. For concrete removal, use a 17-pound (maximum) pneumatic hammer with points that do not exceed the width of the shank or use hand picks or chisels as directed by the Engineer. Do not cut or remove the existing reinforcing steel. Unless specifically directed by the Engineer, do not remove concrete deeper than 1 inch below the reinforcing steel. Prevent cutting, stretching, or damaging of reinforcing steel.

Remove concrete and prepare concrete substrate such that placement of repair material in forms will adequately fill the repair area and will not result in air pockets or honeycombed area. Inside faces should generally be normal to the exterior face, except that the top should slope up toward the front of the form at an approximate 1:3 slope. Provide air vents as necessary. Interior corners should be rounded to a radius of approximately one inch (1”).

As necessary, remove grease, wax, salt, oil, and other contaminants by scrubbing with an industrial grade detergent or degreasing compound followed by a mechanical cleaning. Remove dirt, dust, laitance, and curing compounds by gritblasting, sanding, or etching with 15% hydrochloric acid. Acid etch only if approved by the Engineer. Follow acid etching by scrubbing and flushing with copious amounts of clean water. Check the cleaning using moist pH paper. Water cleaning is complete when the paper reads ten (10) or higher.

Abrasive blast all exposed concrete surfaces and existing reinforcing steel and strand in the repair area to clean the area and remove all loose materials. Use a wire brush or other hand tools to clean all exposed reinforcing steel and strand not sufficiently cleaned by blasting operations.

After blast cleaning, examine the reinforcing steel and prestressing strand. If there is more than 10% reduction in the diameter of reinforcing steel, splice in and securely tie supplemental reinforcing bars within the original concrete cover. Lap the bars sufficiently to develop the full strength of the bar and, if necessary, provide additional removal of concrete to achieve the required splice length. Reinforcing steel that is required for the repairs shall be in accordance with Section 425 of the *Standard Specifications*.

At beam ends where the end of prestressing strand might be free and not anchored in concrete, cut and remove prestressing strand back to even with the prepared concrete substrate. If the length of free, unanchored prestressing strand exceeds 12", or if more than one column of prestressing strand is exposed, notify the Engineer immediately.

If four (4) or more prestressing strands have 50% or greater section loss from their original diameter, one half of the compromised strands shall be repaired by splicing of new strand section at the location of the section loss. Device for splicing shall be a turnbuckle type device and shall be submitted to the Engineer for approval before beginning work. New splice section shall match size of existing strand, and splice device shall be sized for that size strand. Do not splice two (2) adjacent strands unless approved by the Engineer. For strands that are to be spliced, remove concrete such that the full section of the prestressing strand is exposed for a minimum of six (6) inches on each side of the section loss area. Following device manufacturer's recommendations, prepare the strand, removing concrete as necessary, and install splice device and new splice strand. Tensioning of the splice shall be turn-of-the-nut method.

At locations where strand splicing is required, replacement of concrete with repair material shall provide a minimum cover of one inch (1").

Follow all cleaning, remove all dust and loose material with air blast or vacuum cleaning.

Apply HRCSA Penetrant to the prepared reinforcing steel and prestressing strand. Do not apply excessive amount of HRCSA Penetrant; HRCSA shall not extend onto surrounding concrete by more than 1/4". HRCSA Penetrant shall be Zero Volatile Organic Compound (VOC), 100% Solids Penetrant/Sealer (Minimum 15% active sulfonate, a total base number of 135 to 165, must maintain a 9-11 to 1 ratio Active Sulfonate to Total Base Number as determined by Total Base Number Determination testing, Procedure No. 817/4.9/T1401). Allow HRCSA penetrant to dry before placing concrete repair material. Drying time is temperature, humidity, and film thickness dependent. Use manufacturer's recommended drying schedule to estimate the drying time of the penetrating sealer for application of the concrete repair material. If the manufacturer's recommendations allow, the use of forced air pressure to dry the surface will be permitted.

In repair areas that exceed one square foot (1.0 ft<sup>2</sup>) install adhesively anchored 1/4" diameter stainless steel studs in concrete on a 6" x 6" grid. Depth of embedment of adhesively anchored studs shall be 2". Install studs such that concrete cover on the studs is a minimum of one inch (1").

**REPAIR MATERIAL OPTIONS****(A) Polymer Modified Concrete Repair Material**

Repair material shall be polymer modified cement mortar/grout for vertical or overhead applications and shall be suitable for applications in marine environments. Material shall be

approved for use by NCDOT. Submit repair material to the Engineer for review and approval prior to beginning the work. Color of repair material shall be concrete gray.

Prior to the application of polymer modified cement mortar/grout, prepare concrete substrate as indicated in "General Surface Preparation," above. Final preparation of the substrate concrete surface prior to repair material application shall be in accordance with the repair material manufacturer's recommendations.

When surface preparation is completed, mix and apply repair mortar in accordance with manufacturer's recommendations. Use aggregate that is washed, kiln-dried, and bagged. Aggregate size for repair material shall not exceed 2/3 of the minimum depth of the repair area, or 3/4 of the depth of excavation behind the reinforcing steel, whichever is smaller. As recommended by the repair material manufacturer, apply bonding agent to all repair areas immediately prior to placing repair mortar. Repair areas shall be formed, unless otherwise approved by the Engineer. Form areas to establish the original neat lines of the member being repaired, unless otherwise approved by the Engineer.

Unless otherwise allowed by the repair material recommendations, forms shall remain in place until repair material achieves 75% of its design compressive strength.

After placing the repair mortar and form removal, remove excessive material and provide a smooth, flush surface.

**(B) Epoxy Mortar Repair Material**

Use a two-component paste epoxy bonding agent for the epoxy mortar conforming to the requirements for Type 2 epoxies as outlined in Section 1081 of the *Standard Specifications* and Type III epoxies as outlined in ASTM C881.

Prior to the application of epoxy mortar/grout, prepare concrete substrate as indicated in "General Surface Preparation," above. Final preparation of the substrate concrete surface prior to repair material application shall be in accordance with the repair material manufacturer's recommendations.

When surface preparation is completed, mix and apply repair epoxy mortar in accordance with manufacturer's recommendations. Use aggregate that is washed, kiln-dried, and bagged. Aggregate size for repair material shall not exceed 2/3 of the minimum depth of the repair area, or 3/4 of the depth of excavation behind the reinforcing steel, whichever is smaller. Repair areas shall be formed, unless otherwise

approved by the Engineer. Form areas to establish the original neat lines of the member being repaired, unless otherwise approved by the Engineer.

Unless otherwise allowed by the repair material recommendations, forms shall remain in place until repair material achieves 75% of its design compressive strength.

After placing the repair mortar and form removal, remove excessive material and provide a smooth, flush surface.

#### **TEMPORARY WORK PLATFORM**

Prior to beginning any repair work, provide details for a sufficiently sized temporary work platform at each repair location. Design steel members to meet the requirements of the *American Institute of*

*Steel Construction Manual*. Design timber members in accordance with the *National Design Specification for Stress-Grade Lumber and Its Fastenings* of the National Forest Products Association. Submit the platform design and plans for review and approval. The design and plans shall be sealed and signed by a North Carolina registered Professional Engineer. Do not install the platform until the design and plans are approved. Drilling holes in the superstructure for the purpose of attaching the platform is prohibited. Upon completion of work, remove all anchorages in the substructure and repair the substructure at no additional cost to the Department.

#### **MEASUREMENT AND PAYMENT**

*Repairs to Prestressed Concrete Girders* will be measured and paid for at the contract unit price bid per cubic foot and will be full compensation for removal, containment and disposal off-site of unsound concrete, including the cost of materials, reinforcing steel, labor, tools, equipment and incidentals necessary to complete the repair work. Depth will be measured from the original outside concrete face. The Contractor and Engineer will measure quantities after removal of unsound concrete and before application of repair material. Payment will also include the cost of sandblasting, surface cleaning and preparation, cleaning of reinforcing steel, placement of new reinforcing steel, furnishing and application of HRCSA penetrant, furnishing and installation of temporary work platform, testing of the soundness of the exposed concrete surface, furnishing and installation of repair mortar/grout material, curing and sampling of mortar/grout, and protection/cleaning of adjacent areas from splatter or leakage.

*Splicing of Prestressing Strand* will be measured and paid for at the contract unit price bid per each and will be full compensation for removal, containment and disposal off-site of unsound concrete and compromised prestressing strand, including the cost of materials, prestressing strand, turnbuckle strand splice device, labor, tools, equipment and incidentals necessary to complete the repair work. The Contractor and Engineer will determine quantities after removal of unsound concrete and blast cleaning of prestressing strand and before prestressing strand repair. Payment will also include the cost of blast cleaning, removal of concrete necessary for installation of splice devices, and tensioning of the strand and splice section.

Payment will be made under:

15BPR.130

BP-90

Chatham and Moore Counties

**Pay Item**

Repairs to Prestressed Concrete Girders

Splicing of Prestressing Strand

**Pay Unit**

Cubic Feet

Each

**SILANE BARRIER RAIL TREATMENT****(SPECIAL)****DESCRIPTION**

This work consists of preparation of bridge concrete barrier rail surfaces and the furnishing and application of alkylalkoxysilane (silane) penetrant sealers, with 100% solids, to seal bridge concrete barrier rail surfaces and cracks. Prepare the bridge concrete barrier rail surfaces and apply the silane bridge concrete barrier rail sealer in accordance with this special provision and as indicated on the plans, or as approved by the Engineer.

Work includes: bridge concrete barrier rail surface preparation, placement of silane penetrant sealer, appropriate removal and disposal of excess and waste material, and any incidentals necessary to complete the project, as specified or as indicated on the plans.

**SUBMITTALS**

Submit for approval the following requested items and any other relevant documents:

- (A) A safety data sheet (SDS) for each shipment of the silane materials.
- (B) Silane material information and manufacturer's written preparation and application instructions.
- (C) Certification from an independent testing laboratory that the materials meet the requirements of these provisions. Do not incorporate these materials into the project until the Engineer has accepted and approved the certification for the material.
- (D) The dates of manufacture of the silane materials, their lot numbers and date of shelf-life expiration for each lot number.
- (E) A table indicating the likely cure time, in minutes, to allow vehicular traffic on the bridge where the concrete barrier rail surface has been treated. Provide time for the allowable ambient temperature range, in increments of 10° F.
- (F) A work plan for each structure that includes estimated times for surface preparation and silane application.

**MATERIAL DELIVERY AND STORAGE**

Store at the site sufficient quantities of silane materials to perform the entire application.

Deliver materials in manufacturer's original, unopened, undamaged containers with identification labels intact. Ensure that each container is clearly marked by the manufacturer with the following information:

- (A) Manufacturer's name and address.
- (B) Product name.

15BPR.130

BP-91

Chatham and Moore Counties

- (C) Date of manufacture.
- (D) Expiration date.
- (E) Lot identification number.
- (F) Container serial number.

Provide the Engineer a certification from the manufacturer, confirming that the silane materials meet the requirements of this special provision. Do not incorporate these materials into the project until the Engineer has accepted and approved the certification for the material. Submit such certification for each lot of material delivered to the project. In each certification, identify the serial or lot numbers of the containers certified.

The Engineer may require samples from each lot or container of materials delivered to the project or from containers at the point of use. When samples are required, furnish samples in accordance with the Engineer's instructions.

Store silane materials in unopened containers in a clean, dry area between 40° F and 90° F. Store containers in a manner that prevents leakage or spillage.

#### **MANUFACTURER'S REPRESENTATIVE**

Provide a manufacturer's representative on site for the duration of the surface preparation and silane application work, to provide expert assistance on surface preparation, storage, mixing, application, clean-up, and disposal of materials.

#### **MATERIALS**

Provide silane from a single manufacturer and provide silane that conforms to requirements indicated in Table 1, below.

**Table 1**  
**SILANE PROPERTIES**

<b>Property</b>	<b>Test Method</b>	<b>Requirement</b>
Silane Content		100%
VOC content	EPA method 24	Less than 350 g/l
Surface Appearance after Application		Unchanged
Flash Point	ASTM D3278	140° F, minimum
Resistance to Chloride Ion Penetration	AASHTO T259 and T260	Less than: 0.52 pounds/yd <sup>3</sup> (criteria of 1.5) at 1/2 inch level; 0.00 pounds/yd <sup>3</sup> (criteria of 0.75) at 1 inch level
Water absorption test	ASTM C 642	0.50% maximum/48 hours; 1.5% maximum/50 days
Scaling resistance	ASTM C 672	(non-air-entrained concrete) 0 rating "No Scaling" (100 cycles)

NCHRP 244		
Water weight gain	Series II - cube test	85% reduction, minimum
Absorbed chloride		87% reduction, minimum
Absorbed chloride	Series IV - Southern climate	95% reduction, minimum

### **SURFACE PREPARATION**

Prepare the bridge concrete barrier rail surfaces for application of the silane in order to remove all existing grease, slurry, oils, paint, dirt, striping, curing compound, rust, membrane, weak surface mortar, or any other contaminants that could interfere with the proper adhesion, penetration, and the curing of the silane material.

Prepare a final surface that adheres to the following requirements:

- (A) For areas to receive silane treatment, clean by sandblasting or shotblasting. Select the size of shot or sand, and travel speed of the equipment to provide a uniformly clean surface with a uniform profile. Do not expose cleaned surfaces to vehicular traffic unless approved by the Engineer. If the bridge concrete barrier rail surfaces become contaminated before placing the silane treatment, shotblast or abrasive sandblast the contaminated areas to the satisfaction of the Engineer, at no additional cost.
- (B) Power washing of the bridge concrete barrier rail may be allowed as approved by the Engineer, but the concrete barrier shall be allowed to dry a minimum of 48 hours prior to application of the silane treatment.
- (C) Prior to silane application, protect cracks on the bridge concrete barrier rail from materials that can interfere with the penetration and the curing of the silane material. Just prior to placement of the silane, remove, by magnets and oil-free compressed air and vacuuming, any loose particles, such that no excess particles remain.
- (D) Prior to silane application, the bridge concrete barrier rail shall be completely dry.
- (E) The silane manufacturer may suggest cleaning and preparation methods other than those detailed by this special provision. The Engineer must approve such alternative methods prior to implementation.

### **SILANE APPLICATION**

#### **(A) Test Area**

- (1) Test a small area of the surface (minimum 2 ft. by 2 ft.) before general application to ensure desired performance results, aesthetics, and application rates and to verify application technique. Allow 5–7 days for the product to react fully before evaluating.
- (2) Application rates may vary depending on field conditions and the substrate to be treated.
- (3) Conduct at least one absorption test in the test area, using a Rilem Tube Test. Acceptable results are no loss of water in the Rilem tube over a period of 20 minutes. Adjust application to achieve required repellent performance.



- (4) The manufacturer's representative shall assist the Contractor in determining the application rates. Use test applications on actual surfaces to determine accurate application rates. Extremely porous surfaces may require two (2) coats of silane.
- (5) Do not begin production application of silane until Engineer has approved the test area, including approval of aesthetics, color, texture, and appearance.

(B) Application

Immediately before placing silane, all exposed surfaces shall be completely dry and blown clean with oil-free compressed air to remove any loose dust and debris. Apply silane as soon as practical after the exposed surfaces have been properly prepared and conditions are satisfactory:

- (1) Stir material thoroughly before and during application.
- (2) Apply silane using low-pressure pumping equipment with a wet fan type spray nozzle. Rollers with a 1" nap or brushes are permitted. On vertical surfaces, apply the silane in a flooding application from the bottom upward, in accordance with manufacturer's instructions.
- (3) Maintain operating pressures in sprayers used for application of the silane sealer material sufficiently low, so that atomization or misting of the material does not occur.
- (4) Apply even distribution of silane. Take care when applying the silane, so that running or ponding does not occur.
- (5) Apply silane in a single application to the barrier rail surface with enough material to saturate the surface. Remove excess material with a roller or brush and dispose of excess material appropriately. If a second coat is required, it should be applied "wet on wet" before first coat dries.
- (6) Application of sealant by spray methods will not be permitted when wind speeds are 20 mph or more, or if in the opinion of the Engineer, unsatisfactory results will be obtained. Other application methods or rescheduling will be required.
- (7) Avoid application with hand pump sprayers. For small areas of silane application, the use of hand pump sprayers must be approved by the Engineer.
- (8) Contractor shall protect from overspray all pedestrians, vehicles, plants and vegetation, and other areas not receiving silane application. Damages that occur due to overspray shall be the responsibility of the Contractor.
- (9) Allow product to penetrate the bridge concrete barrier rail and dry, as required by the manufacturer, prior to opening to traffic.

**LIMITATIONS OF OPERATIONS**

- (1) Prior to application of any silane sealer, cure concrete or concrete repairs for a minimum of 28 days or as required by the silane manufacturer.
- (2) Do not use silane material after the shelf life date.
- (3) Do not return unused material in opened containers to storage for later use. Either apply such material to appropriate areas on barrier rail surfaces or remove and appropriately dispose of it at offsite locations provided by the Contractor.

- (4) Pick up and store all blast media and contaminants in a vacuum unit. Do not create dust during the blasting operation that will obstruct the view of motorists in roadways adjacent, above, below, or surrounding the silane treatment area. Store, handle, and dispose of blast media and contaminants in accordance with all applicable local, state, and federal requirements.
- (5) Cover deck joint seal and elastomeric material, plug deck drain scuppers, seal cracks on underside of deck, and use other necessary protective measures to prevent leakage of silane below the concrete deck and beyond the concrete barrier rail, to protect waterways, bridge components, pedestrians, vehicles, roadway, vegetation, and any other items or areas below or near the bridge.
- (6) Application of sealant by spray methods will not be permitted during windy conditions, if in the opinion of the Engineer, unsatisfactory results will be obtained. Other application methods or rescheduling will be required.
- (7) Avoid application with hand pump sprayers. For small areas of silane application, the use of hand pump sprayers might be allowed, but must be approved by the Engineer.
- (8) Protect traffic from rebound, dust, overspray, and construction activities. Provide appropriate shielding, as required and/or directed by the Engineer. Damages that occur due to the Contractor's operations shall be the responsibility of the Contractor.
- (9) The Contractor shall provide suitable coverings (e.g. heavy-duty drop cloths) as needed to protect all exposed areas not to receive surface preparation and silane treatment.
- (10) Clean and/or repair all damage or defacement resulting from Contractor's operations to the Engineer's satisfaction at no additional cost to the Department.
- (11) The equipment used for silane application must be clean of foreign materials and approved by the Engineer before use.
- (12) The surface to receive the treatment shall be dry for at least 48 hours before treatment and shall be free from sand, surface dust and dirt, oil, grease, chemical films, and other contaminants prior to application of the silane.
- (13) The surface, air, and material temperatures shall be between 40°F and 90°F during application.
- (14) Do not apply silane materials during cold, hot, or wet weather conditions or when adverse weather conditions are forecasted within 12 hours of the completion of the silane application. Correct any coating damaged by rain or moisture by an additional application or as required by the silane manufacturer.
- (15) Protect prepared surfaces from precipitation and heavy dew during and after the application of the silane.
- (16) Conduct the work in a continuous operation, with the silane application as soon as practical following surface preparation.
- (17) Apply silane during the lowest temperature period of the day, typically between 1:00 a.m. and 9:00 a.m., when the cracks are open to the greatest extent.
- (18) Clean up, dispose of any surplus material, and restore any disturbed areas unless otherwise directed.

15BPR.130

BP-95

Chatham and Moore Counties

- (19) 100% Silane is a combustible liquid; take appropriate precautions during handling, storage, and operations. **KEEP AWAY FROM OPEN FLAME.**
- (20) Work crews should wear appropriate personal protection equipment and follow manufacturer's recommendations when applying silane. Refer to the SDS and all applicable local, state, and federal laws, and rules and regulations of authorities having jurisdiction over the project, for specific guidance for personal and environmental protection and safety requirements.

#### **MEASUREMENT AND PAYMENT**

*Surface Preparation for Silane Barrier Rail Treatment* will be measured and paid for at the contract unit price per square foot and will be full compensation for the shotblasting, sandblasting, or other necessary surface preparation and handwork to prepare the entire bridge concrete barrier rail and removal and disposal of all blast media and waste material generated.

*Silane Barrier Rail Treatment* will be measured and paid for at the contract unit price per square foot and will be full compensation for bridge concrete barrier rail and crack preparation; for furnishing and applying the silane barrier rail treatment; removal and disposal of excess and waste material generated; for protection of waterways, bridge, and other nearby surfaces, vehicles, and pedestrians; and for all labor, tools, and incidentals necessary to complete the work.

Payment will be made under:

<b>Pay Item</b>	<b>Pay Unit</b>
Surface Preparation for Silane Barrier Rail Treatment	Square Foot
Silane Barrier Rail Treatment	Square Foot

#### **EPOXY COATING AND DEBRIS REMOVAL**

(SPECIAL)

##### **GENERAL**

This work applies to all bents and end bents of all bridges throughout the project as noted in the plans. Pressure wash, clean and epoxy coat top of the all bent and end bent caps under open joints and at the expansion joints of steel girder spans after painting of all girders is concluded.

Debris removal from the top of bent caps shall be incidental to epoxy coating the top of bent caps. Use a Type 4A flexible and moisture insensitive epoxy coating in accordance with Section 1081 of the *Standard Specifications*. Provide a Type 3 material certification in accordance with Article 106-3 showing the proposed epoxy meets Type 4A requirements.

##### **SURFACES**

Apply the epoxy protective coating to the top surface area, including chamfer area of bent caps under open joints and expansion joints of the steel girder spans, excluding areas under elastomeric bearings.

15BPR.130

BP-96

Chatham and Moore Counties

Thoroughly clean all dust, dirt, grease, oil, laitance and other objectionable material from the concrete surfaces to be coated. Air blast all surfaces immediately before applying the protective coating.

Use only cleaning agents preapproved by the Engineer.

#### **APPLICATION**

Apply epoxy protective coating only when the air temperature is at least 40°F and rising, but less than 95°F and the surface temperature of the area to be coated is at least 40°F. Remove any excess or free- standing water from the surfaces before applying the coating. Apply one coat of epoxy protective coating at a rate such that it covers between 100 and 200 sf/gal.

Under certain combinations of circumstances, the cured epoxy protective coating may develop an oily condition on the surface due to amine blush. This condition is not detrimental to the applied system.

Apply the coating so the entire designated surface of the concrete is covered and all pores are filled. To provide a uniform appearance, use the exact same material on all visible surfaces.

#### **BASIS OF PAYMENT**

*Epoxy Coating* will be measured and paid for by the contract unit price per square foot and shall be full compensation for furnishing all material, labor, tools and equipment necessary for cleaning and coating the tops of bent caps. Debris removal from the top of bent caps shall be incidental to epoxy coating the top of bent caps.

#### **Pay Item**

Epoxy Coating

#### **Pay Unit**

Square Feet

### **CLEANING AND PAINTING EXISTING BEARINGS WITH HRCSA (SPECIAL)**

#### **DESCRIPTION**

These items of work shall consist of cleaning, preparation, and field application of the specified paint system to existing steel bridge bearings and for all labor, materials, tools and equipment necessary, to complete the work to the limits shown on the plans, described in these special provisions, or as directed by the Engineer.

The bridge bearings shall be cleaned using hand tools, power tools, and high pressure water equipment. Using dry compressed air, connections and crevices will be dried completely. Rust penetrant will be applied to all open connections, crevices, pack rust and rust scale areas. A paint system with a co- polymerized high ratio of 'active' calcium sulfonate (HRCSA) shall be used as a stripe coat at all connections/crevices and as a topcoat over the bearings.

The bearings shall be considered to be plates (including masonry plates, sole plates, embedded

15BPR.130

BP-97

Chatham and Moore Counties

plates, and other associated plates), bolts, nuts, washers, rockers, and any other components or hardware that comprise the bearing assembly.

#### **TWELVE-MONTH OBSERVATION PERIOD**

The Contractor maintains responsibility for the coating system for a 12-month observation period beginning upon the satisfactory completion of all the work required in the plans or as directed by the Engineer. The Contractor shall guarantee the coating system under the payment and performance bond (refer to Article 109-10 of the *Standard Specifications*). To complete successfully the observation period, the coating system shall meet the following requirements after 12 months service:

- (A) No visible rust, contamination or application defect is observed in any coated area.
- (B) Painted surfaces have a uniform color and gloss.
- (C) Painted surfaces have an adhesion that meets an ASTM D3359, 3A rating. Final acceptance is made only after the paint system meets the above requirements.

#### **SUBMITTALS**

Submit all of the following to the Engineer for review and approval before scheduling the pre-construction meeting. Allow at least two (2) weeks for the review process.

- (A) The existing paint systems include toxic substances such as red lead oxide, which are considered hazardous if improperly removed. The contractor shall be currently Society for Protective Coatings (SSPC) Quality Program (QP) 2, Category A certified, and have successfully completed lead paint removal and field painting on similar structures within 18 months prior to this bid. Lead abatement work completed within the 18 month period shall have been completed in accordance with contract specifications, free of citation from safety or environmental agencies. Lead abatement work shall include, but not be limited to: abrasive blasting; waste handling, storage and disposal; worker safety during lead abatement activities (fall protection, personal protective equipment (PPE), etc.); and containment. This requirement is in addition to the contractor pre-qualification requirements covered by Article 102-2 of the *Standard Specifications*.

The apparent low bidder shall submit a list of projects for which QP 2 work was performed within the last 18 months including owner contact information and submit to the Engineer a "Lead Abatement Affidavit". This form may be downloaded from: <https://www.ncdot.gov/initiatives-policies/Transportation/bridges/Documents/leadabatementaffidavit.pdf>

- (B) Work schedule which shall be kept up to date, with a copy of the revised schedule being provided to the Engineer in a timely manner.
- (C) Containment system plans and design calculations in accordance with SSPC Guide 6, Class 2A

and other project requirements, signed and sealed by a Professional Engineer licensed by the State of North Carolina.

- (D) Bridge wash water sampling and disposal plan.
- (E) Subcontractor identification.
- (F) Lighting plan for night work in accordance with Section 1413 of the *Standard Specifications*.
- (G) Traffic control plan with NCDOT certified supervisors, flaggers and traffic control devices.
- (H) Health and safety plan addressing at least the required topics as specified by the SSPC QP 1 and QP 2 program and including hazard communication, respiratory health, emergency procedures, and local hospital and treatment facilities with directions and phone numbers, disciplinary criteria for workers who violate the plan and accident investigation. The plan shall address the following: hazardous materials, personal protective equipment, general health and safety, occupational health and environmental controls, fire protection and prevention, signs signals, and barricades, materials handling, storage, use, and disposal, hand and power tools, welding and cutting, electrical, scaffolds, fall protection, cranes, derricks, hoists, elevators, and conveyors, ladders, toxic and hazardous substances, airless injection and high pressure water jet (HPWJ).
- (I) Provide the Engineer a letter of certification that all employees performing work on the project have blood lead levels that are below the Occupational Safety and Health Administration (OSHA) action level.
- (J) Provide the Engineer with Competent Person qualifications and summary of work experience.
- (K) Environmental Compliance Plan.
- (L) Quality Control Plan (Project Specific) with quality control qualifications and summary of work experience.
- (M) Bridge and Public Protection Plan (Overspray, Utilities, etc. - Project/Task Specific).
- (N) Abrasive Blast Media:
  - (3) Product Data Sheet.
  - (4) Blast Media Test Reports in accordance with Article 1080-12 of the *Standard Specification*.
- (O) Coating Material:
  - (6) NCDOT HICAMS Test Reports (testing performed by NCDOT Materials and Tests Unit).
  - (7) Product Data Sheets.
  - (8) Material Safety Data Sheets.
  - (9) Product Specific Repair Procedures.
  - (10) Acceptance letters from paint manufacturer's for work practices that conflict with special provisions and/or paint manufactures product data sheets.

### **PRE-CONSTRUCTION MEETING**

Submittals shall be reviewed and approved by the Engineer prior to scheduling the pre-construction meeting. Allow no less than two (2) weeks for a review process. When requesting a pre-construction meeting, contact the Engineer at least seven (7) working days in advance of the desired pre-construction date. The contractor's project supervisor, Competent Person, quality control personnel and certified traffic control supervisor shall be in attendance at the pre-construction meeting in order for the Contractor and NCDOT team to establish responsibilities for various personnel during project duration and to establish realistic timeframes for problem escalation.

### **CONTAINMENT SYSTEM**

If a containment plan for Painting of Existing Structure is submitted for a bridge that will have its bearings cleaned and painted with HRCSA, the containment plan for that structural steel painting operation will suffice for cleaning and painting existing bearings with HRCSA. If the

structural steel of a bridge is not to be cleaned and painted, and no containment plan has been submitted for that bridge, and that bridge will have its bearings cleaned and painted with HRCSA, a containment plan for cleaning and painting existing bearings with HRCSA shall be submitted for review and approval.

Prior to performing any construction or painting operations on the structure, the Contractor shall furnish the Engineer with plans and design calculations for a sufficiently designed containment system, which will provide access for any repairs on structural steel members, cleaning and surface preparations for structural steel members, and coating operations for structural steel members of the bridge. The containment system shall not be installed, and no work shall begin, until the Engineer has reviewed and approved, in writing, the submitted containment system plans and design calculations. Containment system plans and design calculations shall be prepared, sealed, and signed by a Professional Engineer licensed by the State of North Carolina. Allow a minimum of two (2) weeks for review of the containment plans and calculations.

The containment system shall meet or exceed the requirements of Class 3W containment in accordance with SSPC Guide 6. The Contractor shall determine the required capacity of the containment system, which, at a minimum, shall include loads due to wind, repair materials and repair operations, equipment, and tools; however, the capacity shall not be less than that required by Federal or State regulations. Design steel members to meet the requirements of the *American Institute of Steel Construction Manual*. Design timber members in accordance with the *National Design Specification for Stress-Grade Lumber and Its Fastenings* of the National Forest Products Association. The containment system shall be constructed of materials capable of withstanding damage from any of the work required on this project and shall provide a two (2) hour resistance to fire.

In the containment system plans, describe how debris is contained and collected. Describe the type of tarpaulin, bracing materials, and the maximum designed wind load. Design wind loads shall be in accordance with the Falsework and Formwork special provision. Describe the dust collection system and how a negative pressure of 0.03 inches of water column is maintained inside the enclosure, while blasting operations are being conducted. Describe how the airflow inside the containment structure is designed to meet all applicable OSHA Standards. Describe how water run-off from rain will be routed by or through the enclosure. Describe how wash water will be contained and paint chips separated. Describe what physical containment will be provided during painting application to protect the public and areas not to be painted.

Drilling holes in the superstructure for the purpose of attaching the containment system is prohibited.

The Contractor will be responsible for certifying the containment system has been constructed in accordance with the approved plans.

The containment system shall be cleaned after each workday.

Upon completion of work, remove all anchorages in the substructure and repair the substructure at no additional cost to the Department.

Protect non-metallic parts of bearings from blasting and painting (i.e.: Pot Bearings, Elastomeric Pads, and Disc Bearings).

#### **WASH WATER SAMPLING AND DISPOSAL PLAN**

All wash water shall be collected and sampled prior to disposal. Representative sampling and testing methodology shall conform to North Carolina Administrative Code 15A NCAC 02B.0103, "Analytical Procedures". Wash water shall be tested for pollutants listed in 15A NCAC 02B.0211(3), 15A NCAC 02T.0505(b)(1) and 15A NCAC 2T.0905(h). Depending on the test results, wash water disposal methods shall be described in the disposal plan. Wash water shall be disposed of in accordance with all current Federal and State regulations. See link for NCDOT Guidelines for Managing Bridge Wash Water:

<https://www.ncdot.gov/initiatives-policies/Transportation/bridges/Documents/WashWater.pdf>

#### **WASTE HANDLING OF PAINT AND ABRASIVES**

Comply with all Federal, State, and local regulations. Failure to comply with the regulations could result in fines and loss of qualified status with NCDOT.

Comply with the Resource Conservation and Recovery Act (RCRA - 40 CFR 261 - 265) and the Occupational Safety and Health Act (OSHA - 29 CFR 1910 - 1926) regulations for employee training, and for the handling, storage, labeling, recordkeeping, reporting, inspections and disposal of all hazardous waste generated during paint removal.

A summary of Generator Requirements is available at the above NCDOT web link, which cites the specific regulations for each Generator category. Quantities of waste by weight and dates of waste generation shall be recorded. Waste stored at the project site shall be properly labeled. All waste, hazardous or non-hazardous, requires numbered shipping manifests.

The North Carolina Department of Environmental Quality (NCDEQ) have adopted RCRA as the North Carolina Hazardous Waste Management Rules and are responsible for enforcement. The *Hazardous Waste Generator Compliance Manual* is published by the Compliance Branch of the Division of Waste Management of NCDEQ, and can be found at:

<https://files.nc.gov/ncdeq/Waste%20Management/DWM/HW/Compliance/Generator%20Compliance%20Manual.pdf>

Immediately after award of the contract, arrange for waste containers, sampling, testing, transportation, and disposal of all waste. No work shall begin until the Contractor furnishes the Engineer with a written waste disposal plan. Any alternative method for handling waste shall be pre-approved by the Engineer. Use an approved waste management company from the following link: <https://www.ebs.nc.gov/VendorDirectory/results.html?sap-params=cD0xJTlwJmN1cnJlbnRfc2VhcmNoX3BhZ2U9d2Mmc2VsZWNoaW9uX2Zpcm1fbmFtZT0mc2VsZWNoaW9uX2NlcnQ9JnNlbGVjdGlvb19maXJtdHlwZT0meXNjX2Zpcm10eXBIPSZzZWxlY3Rpb25fd29ya>



15BPR.130

BP-101

Chatham and Moore Counties

[2xvY2F0aW9uPSZ5c2Nfd29ya2xvY2F0aW9uPSZzZWxlY3Rpb25fYWRkenN0YXRIPSZ5c2NfYWRkenN0YXRIPSZzZWxlY3Rpb25fYWRkcmNvdW50eT0meXNjX2FkZHJjb3VudHk9JnNlbGVjdGlubl93a2NvZGU9MDAzMDQwJnlzY193a2NvZGU9MDAzMDQwJTlwQ09OVEFNSU5BVEVEJTIwTUFURVJJO UxTJTIw UkVNT1ZBTCZzZWxlY3Rpb25fZGlzYz0meXNjX2Rpc2M9JnNlbGVjdGlubl9uYWljcz0meXNjX25haWNzPSZzZWxlY3Rpb25fY3R5cGU9MA%3d%3d](https://ncdenr.s3.amazonaws.com/s3fs-public/document-library/Lead%20Disposal.pdf)

All removed paint and spent abrasive media shall be tested for lead following the SW-846 Toxicity Characteristic Leaching Procedure (TCLP) Method 1311 Extraction, as required in 40 CFR 261, Appendix 11, to determine whether it shall be disposed of as hazardous waste. Furnish the Engineer certified test reports showing TCLP results of the paint chips stored on site, with disposal in accordance with “Flowchart on Lead Waste Identification and Disposal” at:

<https://ncdenr.s3.amazonaws.com/s3fs-public/document-library/Lead%20Disposal.pdf>

All sampling shall be done in presence of the Engineer’s representative.

The Competent Person shall obtain composite samples from each barrel of the wash water and waste generated by collecting two or more portions taken at regularly spaced intervals during accumulation. Composite the portions into one sample for testing purposes. Acquire samples after 10% or before 90% of the barrel has accumulated. The intent is to provide samples that are representative of widely separated portions, but not the beginning and end of wash water or waste accumulation.

Perform sampling by passing a receptacle completely through the discharge stream or by completely diverting the discharge into a sample container. If discharge of the wash water or waste is too rapid to divert the complete discharge stream, discharge into a container or transportation unit sufficiently large to accommodate the flow and then accomplish the sampling in the same manner as described above.

Comply with the NCDEQ *Hazardous Waste Compliance Generator Manual*. Record quantities of waste by weight and dates of waste generation. Until test results are received, store all waste, and label as “NCDOT Bridge Paint Removal Waste - Pending Analysis” and include the date generated and contact information for the Engineer. Store waste containers in an enclosed, sealed, and secured storage container protected from traffic from all directions. Obtain approval for the protection plan for these containers from the Engineer. If adequate protection cannot be obtained by use of existing guardrail, provide the necessary supplies and equipment to maintain adequate protection. Once test results are received and characterized, label waste as either “Hazardous Waste - Pending Disposal” or “Paint Waste - Pending Disposal”.

15BPR.130

BP-102

Chatham and Moore Counties

Once the waste has been collected, and the quantities determined, prepare the appropriate shipping documents and manifests and present them to the Engineer. The Engineer will verify the type and quantity of waste and obtain a Provisional Environmental Protection Agency (EPA) ID number from:

Melodi Deaver  
Division of Waste Management/Hazardous  
Waste Section North Carolina Department of  
Environmental Quality 1646 Mail Service Center  
Raleigh, NC 27699  
Phone: (919) 707-8204, Email: [melodi.deaver@ncdenr.gov](mailto:melodi.deaver@ncdenr.gov)

At the time of shipping, the Engineer will sign, date, and add the ID number in the appropriate section on the manifest. The maximum on-site storage time for collected waste shall be 90 calendar days. All waste whether hazardous or non-hazardous will require numbered shipping manifests. The cost for waste disposal (including lab and Provisional EPA ID number) is included in the bid price for this contract. Note NC Hazardous Waste Management Rules (15A NCAC 13A) for more information. Provisional EPA ID numbers may be obtained at: <https://deq.nc.gov/about/divisions/waste-management/hw/provisional-notification>

15BPR.130

BP-103

Chatham and Moore Counties

Testing labs shall be certified in accordance with North Carolina State Laboratory Public Health Environmental Sciences. List of certified laboratories may be obtained at: <https://slphreporting.ncpublichealth.com/Certification/CertifiedLaboratory.asp>

All test results shall be documented on the lab analysis as follows:

(B) For leachable lead:

(1) Soils/Solid/Liquid- EPA 1311/200.7/6010

Area sampling will be performed for the first two (2) days at each bridge location. The area sample will be located within five (5) feet of the containment and where the highest probability of leakage will occur (access door, etc.). Results from the area sampling will be given to the Engineer within 72 hours of sampling (excluding weekends). If the results of the samples exceed  $20 \mu\text{g}/\text{m}^3$  corrective measures shall be taken and monitoring shall be continued until two (2) consecutive sample results are less than  $20 \mu\text{g}/\text{m}^3$ .

Time Weighted Average (TWA) may suspend the work if there are visible emissions outside the containment enclosure or pump monitoring results exceeding the level of  $30 \mu\text{g}/\text{m}^3$ .

Where schools, housing and/or buildings are within 500 feet of the containment, the Contractor shall perform initial Total Suspended Monitoring (TSP) Lead monitoring for the first ten (10) days of the project during abrasive blasting, vacuuming and containment removal. Additional monitoring will be required during abrasive blasting two (2) days per month thereafter. Results of the TSP monitoring at any location shall not exceed  $1.5 \mu\text{g}/\text{m}^3$ .

#### **EQUIPMENT MOBILIZATION**

The equipment used in any travel lanes and paved shoulder shall be mobile equipment on wheels that has the ability to move on/off the roadway in less than 30 minutes. All work conducted in travel lanes shall be from truck or trailer supported platforms and all equipment shall be self-propelled or attached to a tow vehicle at all times.

#### **QUALITY CONTROL INSPECTOR**

Provide a quality control (QC) inspector in accordance with the SSPC QP guidelines to ensure that all processes, preparation, blasting and coating application are in accordance with the requirements of the contract. The inspector shall have written authority to perform QC duties to include continuous improvement of all QC internal procedures. The presence of the engineer or inspector at the work site shall in no way lessen the contractor's responsibility for conformity with the contract.

#### **QUALITY ASSURANCE INSPECTOR**

The quality assurance inspector which may be a Department employee or a designated representative of the Department shall observe, document, assess, and report that the Contractor is complying with all of the requirements of the contract. Inspectors employed by the Department are authorized to inspect all work performed and materials furnished. Such inspection may extend to all or any part of the work and to the preparation, fabrication, or manufacture of the materials to be used. The inspector is not authorized to alter or waive the requirements of the contract. Each stage in preparing the structure to be coated which includes but not limited to washing, blasting, coating testing and inspection shall be inspected and approved by the Engineer or an authorized representative.

15BPR.130

BP-104

Chatham and Moore Counties

**SUBLETTING OF CONTRACT**

Only contractors certified to meet SSPC QP 2, Category A, and have successfully completed lead paint removal and field painting on all similar structures within 18 months prior to this bid are qualified for this work. Work is only sublet by approval of the Engineer.

**PREPARATION OF SURFACES****(A) Removal of Soil, Concrete, Debris, and Other Material**

Soil, concrete, debris, and other foreign material that might be on or attached to the bearings, plates, or any other bearing components shall be removed. Removal of such material may require the use of brooms, brushes, hand tools, hammers, chisels, pneumatic hammers, or other tools or power tools. Pneumatic hammers used for removal of such material shall weigh a nominal 15 lbs. or less. Exercise care to avoid nicking or gouging the bearing components during removal of soil, concrete, debris, and other foreign material. Should damage occur, repairs shall be made to the bearings at no cost to the Department.

**(B) Cleaning and Removal of Pack Rust**

Removal of pack rust shall be done by hand tool cleaning to meet requirements of SSPC Surface Preparation (SP)-SP 2, or by power tool cleaning to meet requirements of SSPC-SP 3, or a combination of these methods. Any black oxide scale shall be removed, unless otherwise directed by the Engineer. Pay particular attention to crevice areas when removing pack rust and rust scale. Exercise care to avoid nicking or gouging the bearing components during removal. Remove all rust scale and loose pack rust, followed by high pressure water cleaning.

**(C) High Pressure Water Cleaning (HPWC)**

The bearings shall be cleaned with water at a minimum pressure of 5,000 psi, at five (5) gallons per minute, with a rotating tip, at a maximum four (4) inch standoff distance from the steel surface, held as perpendicular to the steel surface as possible.

All water to be used in the surface preparation shall be potable water.

Ambient wash water temperature is allowed; hot water is not necessary.

The wash water shall include a soluble salt removing chemical at a minimum ratio of 100:1 and in compliance with manufacturer recommendations.

Care should be taken to ensure that the potable wash water does not have a level of chloride exceeding 15 parts per million (ppm) when tested. If higher, the level of soluble salt removing chemical should be proportionally increased as per manufactures recommendation.

It should be expected that the surfaces of the steel (and connections) are contaminated with soluble salts (e.g. Chlorides, Sulfates, or Nitrates). Using an acceptable sample method in accordance with SSPC Guide 15, ensure that soluble salt levels on the surfaces do not exceed allowable soluble salt limits listed below:

(1) Chloride - NVC3 3  $\mu\text{g}/\text{cm}^2$

15BPR.130

BP-105

Chatham and Moore Counties

- (2) Sulfate - NVS10 10  $\mu\text{g}/\text{cm}^2$
- (3) Nitrate - NVN10 10  $\mu\text{g}/\text{cm}^2$

The frequency of testing shall be two (2) tests per span after all surface preparation has been completed and immediately prior to painting. Select test areas representing the greatest amount of corrosion in the span as determined by the Engineers' representative. Additional testing may be required if significant amounts of chloride are detected.

The surface cleaning shall meet the requirements of SSPC Waterjet (WJ)-WJ4, to remove loose paint and loose rust. SSPC SP2 or SP3 (hand or power tool cleaning) may be used in inaccessible areas or when water cleaning is not possible.

In some cases, after HPWC, there may be areas of tightly adhered black oxide that were not removed. All black oxide scale shall be removed, unless otherwise directed by the Engineer.

If there is a question of whether all loose paint has been removed, adhesion testing of the remaining "tightly adhered" paint shall be done in accordance with ASTM D 4541-02 Standard Test Method for Pull-Off Strength of Coatings Using Portable Adhesion Testers, with a minimum value of 300 psi.

Care should be taken to ensure all crevice corroded and pack rusted joints connections and corrosion frozen bearings are flushed with water containing a soluble salt removing chemical, at a minimum pressure of 5,000 psi, at five (5) gallons per minute, to ensure removal of all loose materials and to flush out any contaminant.

#### (D) Compressed Air Drying

All joints, connections, and bearings shall be blown dry with clean, dry, oil free, high pressure (100 psi) compressed air, regardless if the areas appear to be dry. Use the white blotter test in accordance with ASTM D4285 to verify the cleanliness of the compressed air used for blowout of "Limited Access" areas and drying. Conduct the test at least once per shift for each compressor system. Sufficient freedom from oil and moisture is confirmed if soiling and/or discoloration are not visible on the paper. If air contamination is evidenced, change filters, clean traps, add moisture separators or filters, or make adjustments as necessary to achieve clean, dry air.

All surfaces shall be inspected at this point. Surface preparation found to be deficient will be repeated at the Contractor's expense as directed by the Engineer. Once areas are agreed to be satisfactory, the Contractor may proceed with penetrating sealer application.

### **PAINTING OF STEEL**

#### (A) Penetrating Sealer

Penetrating sealer may be applied by brush, roller, or airless spray method as recommended by the manufacturer. The mixing amount and method of mixing for the sealer components must be in accordance with the manufacturer's instruction. Wet coat sufficiently to completely cover and penetrate the steel surface, but do not apply heavy coat. Use coat thickness as recommended by the manufacturer. Apply liberally to crevices and joints and/or spaces where a gap has been created between plates and around bolts, nuts and washers. Allow material to soak into spaces. Brush out any excess material, so as to not retard curing of the topcoat or result in an unaesthetically pleasing

surface.

The penetrating sealer shall be applied within 24-hours after completion of the cleaning operations and before flash-rusting occurs. No bare steel surface prepared for penetrating sealer application shall be left uncoated long enough to allow the formation of rust. Cleaned areas upon which rust has formed shall be re-cleaned in accordance with the cleaning requirement at no additional cost. The presence of rust shall be determined by the Engineer.

The receiving steel surface shall be clean and absolutely dry. The permissible steel surface temperature and the ambient temperature shall be as recommended by the sealer manufacturer. However, in no case, shall the penetrating sealer be applied when the steel surface or the ambient temperatures is below 36°F or above 104°F, or the relative humidity exceeds 99% or a 3.6°F (2°C) temperature-Dew Point temperature spread.

Drying time is temperature, humidity, and film thickness dependent. Use manufacturer's recommended drying schedule to estimate the drying time of the penetrating sealer for application of the other coatings. If the manufacturer's recommendations allow, the use of forced air pressure to dry the surface will be permitted.

(B) HRCSA – Striping and Topcoat

No application of any stripe/primer shall be allowed until cleaning and preparation of the substrate has been approved by the Engineer. See drawings to determine exact location of structure components to be painted.

The permissible steel surface temperature and the ambient temperature shall be as recommended by the coating manufacturer. However, in no case, shall the coating be applied when the steel surface or the ambient temperatures is below 36°F or above 104°F, or the relative humidity exceeds 99% or a 3.6°F (2°C) temperature-Dew Point temperature spread.

The Contractor shall provide paint brushes, rollers, and spray equipment to conduct the work as specified in this special provision.

The Contractor shall also provide specialized equipment as required for the painting of limited access areas and for other difficult-to-clean areas. Specialized equipment may include, but is not limited to:

- (1) Pole guns for spray painting.
- (2) Mitts, daubers, or other methods to supplement brush application.

Stripe painting will be required on the following surfaces that have been cleaned: edges of plates, angles, lattice, connections (rivets and bolt heads) or other shapes, corners, crevices, back-to-back angles, and built-up edges. The surfaces of existing steel members to which new steel may be connected (faying surfaces) shall also be cleaned and painted as herein described. The stripe coat shall have a band width of at least four (4) in. (101.6 mm) to each side of the adjoining edges and is to completely coat the interior of all crevices. All stripe painting should be applied by spray, but immediately afterwards it may be "brushed in" using a brush. No other method of paint application will be allowed for stripe painting.

Paint for intermediate coat or topcoat may be applied using spray, brush, or roll methods.

15BPR.130

**BP-107**

Chatham and Moore Counties

Spray painting will be permitted only within a containment that will contain all of the sprayed material, as approved by the Engineer. Complete protection from paint spatter, spillage, overspray, wind-blown paint, or similar releases of paint shall be provided. Covers, tarps, mesh, and similar materials shall be placed around the work area to protect public and private property, pedestrian, vehicular, marine, or other traffic, all portions of the bridge, highway appurtenances, waterways, and similar surrounding areas and property, upon, beneath, or adjacent to the structure.

Apply HRCSA as directed by the manufacturer. Wait time between the stripe coats, intermediate coats, and the topcoat shall be as per the manufacturer's recommendations. The following paint schedule shall be used unless special exceptions are submitted and approved according to manufacturer recommendations prior to the start of this work.

<b>Application Location</b>	<b>Description</b>	<b>Film Thickness</b>
SPOT	Liberally apply a stripe coat to crevice corroded and pack rusted bearings and connections, provide extra material to bolts, nuts and any gaps around rivets.	15-18 mils (wet) 10-12 mils (dry)
SPOT	Over exposed metal areas and areas of tightly adhered contaminant free rust or flash rust, apply a spot prime with 5 to 7 mils DFT of Topcoat, including areas mentioned in previous SPOT application.	7-10 mils (wet) 5-7 mils (dry)

Prior to placing the subsequent coats, the Contractor will ensure that the prior coat is clean of all foreign matter, such as grease, dirt, bird waste, etc., before application of the subsequent coat.

Sealer, stripe, spot, and finish coats shall be applied in sufficient quantity so as to produce the minimum specified Dry Film Thicknesses (DFT). Care should be taken to not over apply the primer/topcoat, especially on flat surfaces. Maximum 25 mils DFT.

Active calcium sulfonate coatings cure slowly, so wet film measurements may be used as criteria for **preliminary** acceptance of the coating. Wet film thickness (WFT) measurements shall be determined as the job progresses and corrections shall be made during paint application.

Dry film thicknesses shall be determined using SSPC Paint Application (PA) PA2 – using a digital film thickness gage and a shim – after the coating has cured sufficiently to allow accurate measurements. Depending upon ambient air conditions, it may take more than one week before DFT measurements can be taken.

Areas failing to meet the specified WFT range shall be over-coated with the same paint to produce at least the total WFT required.

Paint applied containing unauthorized thinners, paint applied to contaminated surfaces, and paint applied contrary to this special provision shall result in the re-cleaning and re-painting of

15BPR.130

**BP-108**

Chatham and Moore Counties

the surface. The work of re-cleaning, re-painting, or over-coating, if required, shall be performed within ten (10) working days following notification by the Engineer and shall be done by the Contractor to the satisfaction of the Engineer, at no additional cost to the Department.

**MATERIALS****(A) Penetrant and Paint System**

The paint system to be used shall be a High Ratio Co-Polymerized Calcium Sulfonate (HRCSA) coating system. Characteristics of submitted products shall meet or exceed those of the requirements listed within this special provision.

The structure is to be coated with a High Ratio, Co-Polymerized Calcium Sulfonate (HRCSA) corrosion mitigation system. Any Contractor-proposed coating system shall meet the following requirements:

- (1) The proposed coating system shall be an HRCSA coating as defined by this special provision and shall be submitted for approval.
  - (a) Primer/Topcoat (Minimum 9.5% active sulfonate) must maintain a 9-11 to 1 ratio Total Base Number to Active Sulfonate, i.e., total base number of 85 to 104 to 9.5% Active Sulfonate, as determined by Percent Active Sulfonate Content by Cationic Titration (Hyamine) testing, Procedure No. 817/4.9/T1409A.
  - (b) Formulations with greater than 27% Alkyd or co-polymer are not valid HRCSA.
  - (c) Zero Volatile Organic Compounds (VOC), 100% Solids Penetrant/Sealer approved by HRCSA manufacturer (Minimum 15% active sulfonate, a total base number of 135 to 165, must maintain a 9-11 to 1 ratio Active Sulfonate to Total Base Number as determined by Total Base Number Determination testing, Procedure No. 817/4.9/T1401.
- (2) The proposed coating system shall be certified in writing by the coating manufacturer that the HRCSA Primer/Topcoat and the HRCSA Penetrant Sealer meets the HRCSA special provision and has been verified by the testing titration protocols indicated above. The Engineer may choose to perform verification testing using the same protocols on materials delivered to the job site.
- (3) The proposed coating formulation shall have independent laboratory tests showing that the HRCSA coating, as supplied, has been tested to ASTM D5894 with a 24 hour freeze-thaw cycle and has passed a minimum 5,000 hours with no rust creepage at the scribe. The manufacturer shall certify that the currently manufactured formulation used is the same as the formulation that was tested, and can supply supporting documentation.

Lighting shall be equipped with explosion-proof fixtures.

The accumulation of empty paint cans, combustibles, and other debris will not be permitted.

Material Safety Data Sheets (MSDS) sheets for all materials shall be maintained on file and provided to the Engineer prior to receipt of the material from the manufacturers.

If required, paint shall be mixed with mechanical mixers in accordance with the paint manufacturer's recommendations.



15BPR.130

**BP-109**

Chatham and Moore Counties

The primer, stripe, and other coats may be thinned only if recommended by the manufacturer, done in compliance with the manufacturer's instructions, approved by the Engineer, and mixed in the presence of the Engineer. If recommended by the manufacturer and approved by the Engineer, a measuring cup, having graduation in ounces, shall be used in the addition of thinner to any paint. No "eye balling" during addition of thinner to paint will be allowed. Paint mixed with thinner by "eye balling" will be subject to rejection by the Engineer as ruined material.

**(B) Penetrant and Paint Storage**

Do not expose penetrant and paint materials to rain, excessive condensation, long periods of direct sunlight, or temperatures above 100°F or below 40°F. In addition, the Contractor shall place a device which records the high, low, and current temperatures inside the storage location. Follow the manufacturer's storage requirements if more restrictive than the above requirements. Any material found to be damaged or beyond its expiration date shown on the container shall be immediately removed from the project site and will be considered as ruined material.

All storage of paint, solvents, and other materials applied to structures shall be stored in accordance with Subarticle 442-9(C) of the *Standard Specifications* or the manufacturers' requirements. The more restrictive requirements will apply.

**(C) Testing of Paint Samples**

Engineer reserves the right to conduct tests of the materials at any time, and any number of times during the period of field painting.

The Engineer will sample the paint(s) being used. A representative size sample of each component of paint(s) at the construction site will be transferred to metal containers, identified, sealed, and certified in the presence of the Contractor.

Tests on paint samples may be performed by the Department in order to confirm the manufacturer's test results submitted with each batch of material.

If the laboratory test results show that the material being used does not comply with the requirements specified in this special provision, the Contractor will be directed to stop painting work and remove non-complying paint; pay for testing; re-paint surfaces coated with rejected paint; or remove rejected paint from previously painted surfaces if, upon re-painting with specified paint, the two (2) coatings are not compatible.

**INSPECTION**

Surface Preparation for System 1 shall be in accordance with SSPC SP-10. Any area(s) not meeting the requirements of SSPC SP-10 shall be remediated prior to application of coating. Surface inspection is considered ready for inspection when all blast abrasive, residue and dust is removed from surfaces to be coated.

**(D) Quality Assurance Inspection**

The Contractor furnishes all necessary OSHA approved apparatus such as ladders, scaffolds and platforms as required for the inspector to have reasonable and safe access to all parts of the work.

15BPR.130

BP-110

Chatham and Moore Counties

The contractor illuminates the surfaces to be inspected to a minimum of 50-foot candles of light. All access points shall be illuminated to a minimum of 20-foot candles of light.

NCDOT reserves the right for ongoing Quality Assurance (QA) inspection to include but not limited to surface contamination testing, adhesion pull testing, and DFT readings as necessary to assure quality.

Inform the Engineer and the Division Safety Engineer of all scheduled and unannounced inspections from SSPC, OSHA, EPA and/or others that come on site. Furnish the Engineer a copy of all inspection reports except for reports performed by a third party and or consultant on behalf of the Contractor.

(E) Inspection Instruments

At a minimum, furnish the following calibrated instruments and conduct the following quality control tests:

- (12) Sling Psychrometer - ASTM E337 - bulb type
- (13) Surface Temperature Thermometer
- (14) Wind Speed Indicator
- (15) Tape Profile Tester - ASTM D4417 Method C
- (16) Surface Condition Standards - SSPC VIS-1 and VIS-3
- (17) Wet Film Thickness Gage - ASTM D4414
- (18) Dry Film Thickness Gage - SSPC-PA2 Modified
- (19) Solvent Rub Test Kit - ASTM D4752
- (20) Adhesion Test Kit - ASTM D3359 Method A (Tape Test)
- (21) Adhesion Pull test - ASTM D4541
- (22) Surface Contamination Analysis Kit or (Chloride Level Test Kit) SSPC Technology Guide 15

(F) Quality Control

Maintain a daily quality control record in accordance with Subarticle 442-12(D) of the *Standard Specifications* and make such records available at the job site for review by the inspector and submit to the Engineer as directed. In addition to the information required on Form M&T-610, submit all Dry Film Thickness (DFT) readings on a form equivalent to Form M&T-611. These forms can be found at:

<https://connect.ncdot.gov/resources/Materials/Pages/Materials-Manual-by-Material.aspx?Order=MM-03-02>

Film thickness shall be measured at no less than six (6) random spots per bearing (each of four (4) bearing plate edges and two (2) readings on top of the sole plate). Also, film thickness shall be measured at no less than six (6) random spots per span on diaphragms/cross frames.

Each spot is an average of three (3) to five (5) individual gage readings as defined in SSPC PA-2. No spot average shall be less than 80% of minimum film thickness for each layer applied; this does not apply to stripe coat application. These non-conforming areas shall be corrected by the Contractor prior to applying successive coats.

Areas failing to meet the specified film thickness range shall be over-coated with the same paint to produce at least the total film thickness required.

15BPR.130

BP-111

Chatham and Moore Counties

**REPAIR OF DAMAGED COATINGS**

All damaged coatings, new or existing, shall be repaired prior to project completion and acceptance in accordance with the above specifications for re-coating and over-coating and as directed by the Engineer, at no additional cost to the Department.

**COATING MANUFACTURER'S REPRESENTATIVE**

Unless waived by the Engineer, the Contractor shall make arrangements for a representative of the coating manufacturer to be present on-site as work begins, at a minimum, and as necessary as work progresses, to work together with the Contractor and representatives of the Department and to provide comments and guidance, so that the cleaning, application, and inspection procedures are done properly.

**SAFETY AND ENVIRONMENTAL COMPLIANCE PLANS**

Personnel access boundaries are delineated for each work site using signs, tape, cones, or other approved means. Submit copies of safety and environmental compliance plans that comply with SSPC QP 2 Certification requirements.

**HEALTH AND SAFETY RESPONSIBILITIES**

This project may involve toxic metals such as arsenic, lead, cadmium and hexavalent chromium. It is the contractor's responsibility to test for toxic metals and if found, comply with the OSHA regulations, which may include medical testing.

Ensure a "Competent Person" as defined in OSHA 29 CFR 1926.62; one who is capable of identifying existing and predictable hazards in the surroundings or working conditions which are unsanitary, hazardous, or dangerous to employees, and who has authorization to take prompt corrective measures to eliminate them; is on site during all surface preparation activities and monitors the effectiveness of containment, dust collection systems and waste sampling. Before any work begins, provide a written summary of the Competent Person's safety training.

Comply with Subarticle 442-14(B) of the *Standard Specifications*.

Comply with Subarticle 442-14(D) of the *Standard Specifications*. Ensure employee blood sampling test results are less than 50 micrograms per deciliter. Remove employees with a blood sampling test of 50 or more micrograms per deciliter from work activities involving any lead exposure.

An employee who has been removed with a blood level of 50 micrograms per deciliter or more shall have two (2) consecutive blood sampling tests spaced one week apart indicating that the employee's blood lead level is at or below 40 micrograms per deciliter before returning to work activities involving any lead exposure.

All OSHA recordable accidents that occur during the project duration are to be reported to the Engineer within twenty-four (24) hours of occurrence. In addition, for accidents that involve civilians or property damage that occurs within the work zone the Division Safety Engineer shall be notified immediately.

Prior to blasting operations, the Contractor shall have an operational OSHA approved hand wash station at each bridge location and a decontamination trailer at each bridge or between bridges unless the work is on the roadway, or the Contractor shall show reason why it is not feasible to do so and

15BPR.130

BP-112

Chatham and Moore Counties

provide an alternative site as approved by the Engineer. The Contractor shall assure that all employees whose airborne exposure to lead is above the Permissible Exposure Limit (PEL) shall shower at the end of their work shift.

#### **STORAGE OF PAINT AND EQUIPMENT**

Provide a location for materials, equipment, and waste storage. Spread tarpaulins over all pavements and surfaces underneath equipment used for abrasive recycling and other waste handling equipment or containers. All land and or lease agreements that involve private property shall disclose to the property owner that heavy metals may be present on the Contractor's equipment. Prior to storing the Contractor's equipment on private property, provide a notarized written consent signed by the land owner received by the Engineer at least forty-eight (48) hours before using property. All storage of paint, solvents, and other materials applied to structures shall be stored in accordance with Subarticle 442-9(C) of the *Standard Specifications* or the manufacturers' requirements. The more restrictive requirements will apply.

#### **UTILITIES**

Protect all utility lines or mains that may be supported on, under, or adjacent to bridge work sites from damage and paint overspray.

#### **MEASUREMENT AND PAYMENT**

*Painting Containment for Bridge No.* will be paid for at the contract unit price which will be full compensation for the design, materials, installation, maintenance, and removal of the containment system.

*Pollution Control* will be paid at the contract lump sum price which will be full compensation for all collection, handling, storage, air monitoring, and disposal of debris and wash water, all personal protective equipment, and all personal hygiene requirements, and all equipment, material and labor necessary for the daily collection of the blast debris into specified containers; and any measures necessary to ensure conformance to all safety and environmental regulations as directed by the Engineer.

*Cleaning and Painting Existing Bearings* will be measured and paid for each bearing location. The price for each bearing will be full compensation for all labor, materials and equipment necessary to complete the work. All work shall be done in a manner satisfactory to the Engineer.

Payment will be made under:

<b>Pay Item</b>	<b>Pay Unit</b>
Painting Containment for Bridge No. ____	Lump Sum
Pollution Control	Lump Sum
Cleaning and Painting Existing Bearings with High Ratio Calcium Sulfonate	Each

**BRIDGE JACKING****(SPECIAL)****DESCRIPTION**

Bridge jacking at end bents and interior bents is to facilitate beam or bent cap repairs and to replace and/ or reset bearings, as necessary. This work shall consist of furnishing all engineering, labor, equipment, and materials necessary for construction and subsequent removal of jacking support system, including jacks, jack supports, shims and all necessary blocking. Included under this item shall be all work to raise and support the existing structure as specified on the plans and as noted herein.

**UTILITY COORDINATION**

Utility owners with active utilities on the bridge shall be notified by the contractor of the jacking operation 30 days before the operation begins.

**SCOPE OF WORK**

Work for bridge jacking includes calculating existing and applied bridge loads, designing proper strength jacking scheme, evaluating stresses imposed on the bridge members, setting blocking and jacks, jacking bridge girders, mechanically locking jacks, and lowering bridge spans onto bearing assemblies.

Submit calculations, working drawings, and jacking procedure to the Engineer for review and approval prior to the start of work. Calculations and jacking procedure shall account for all loads expected while bridge is jacked or temporarily supported. Working drawings and all calculations (for determination of all applied loads, for design of the jacking scheme, to evaluate stresses imposed on the bridge members, and any other necessary calculations) for the required jacking scheme shall be sealed by an engineer licensed in the State of North Carolina.

Thoroughly clean areas under the proposed jacks to provide a flat, clean jacking surface. When jacking surfaces are not level or have slightly deteriorated concrete areas, use non-shrink grout to repair them to a flat level surface. The minimum thickness of the grout shall be as recommended by the manufacturer.

If the Engineer determines that any jacking surface contains highly deteriorated concrete, delay all work at that location and initiate provisions for pneumatically applied mortar or cast in place concrete repairs to restore the surface to full capacity for the jacking operations.

Do not remove any steel that has been welded to the existing bridge; it shall remain in place. The Contractor may opt to leave the jacking beam in place unless otherwise specified.

Make test cubes or cylinders of the nonshrink grout or concrete used for bearing pedestal repairs. The beams shall not be lowered in place until the test specimens achieve 3,500 psi minimum compressive strength.

The jack system shall be equipped with a direct reading gauge to directly read the jack force in pounds or kips. However, a gauge accompanied by a chart with which the dial reading can be

converted into pounds may be used if approved by the Engineer.

Prior to bridge jacking, complete all diaphragm modifications necessary at the location where jacking is to occur. If a span connected to an end bent is to be jacked, ensure the curtain wall is either clear of the girders, or fully free to move with the jacked span prior to jacking. Lock jacks and install blocking while the bridge is in the raised condition. While in the raised condition, follow bridge plans for any work that may be required. Complete repair work, as needed. After all repairs requiring bridge jacking are completed, lower the bridge onto the bearing assemblies.

Unless otherwise allowed by the Engineer, all bridge jacking operations shall be complete before new deck overlay or deck joints and seals are placed on the existing structure.

Bridge jacking will be designated as one of two jacking arrangements, as

follows: Type I

Type I Bridge Jacking shall be applicable for jacking at individual beam or bearing locations. On a particular bridge bent or end bent, there might be more than one Type I Bridge Jacking. When jacking individual beam or bearing locations, all adjacent bearings of beams not being jacked may be loosened to decrease the resistance of the deck slab during jacking. The maximum differential between adjacent beams that are being jacked is  $\frac{1}{8}$ ". Should the jacking of an individual beam require the jacking of adjacent beams to reduce stresses or damage in the bridge, the jacking of the individual beam and adjacent beams shall be considered one Type I Bridge Jacking. All bearings loosened shall be tightened back after repair operations are completed and the jacks and blocking have been removed.

Type II

Type II Bridge Jacking shall be applicable for jacking an entire span end (i.e., all beams at one time) on a bent or end bent.

#### **BASIS OF PAYMENT**

*Type I Bridge Jacking Bridge No.* payment will be made at the price bid for each set-up to complete bridge jacking as shown in the contract plans. The price per each jacking set-up required will be full compensation for designing proper strength jacking scheme (calculations, working drawings, and jacking procedure), all materials, equipment, tools, labor, and incidentals necessary to complete the work of this scope, including any jacking frames, jacking plates, and concrete repair required due to jacking operations.

15BPR.130

# BP-115

Chatham and Moore Counties

*Type II Bridge Jacking Bridge No.* payment will be made at the price bid for each set-up to complete bridge jacking as shown in the contract plans. The price per each jacking set-up required will be full compensation for designing proper strength jacking scheme (calculations, working drawings, and jacking procedure), all materials, equipment, tools, labor, and incidentals necessary to complete the work of this scope, including any jacking frames, jacking plates, and concrete repair required due to jacking operations.

<b>Pay Item</b>	<b>Pay Unit</b>
Type I Bridge Jacking Bridge No. _____	Each
Type II Bridge Jacking Bridge No. _____	Each

County: CHATHAM, MOORE

Line #	Item Number	Sec #	Description	Quantity	Unit Cost	Amount
<b>ROADWAY ITEMS</b>						
0001	0000100000-N	800	MOBILIZATION	Lump Sum	L.S.	
0002	1330000000-E	607	INCIDENTAL MILLING	312 SY		
0003	1523000000-E	610	ASPHALT CONC SURFACE COURSE, TYPE S9.5C	26.4 TON		
0004	1575000000-E	620	ASPHALT BINDER FOR PLANT MIX	1.6 TON		
0005	4400000000-E	1110	WORK ZONE SIGNS (STATIONARY)	233 SF		
0006	4405000000-E	1110	WORK ZONE SIGNS (PORTABLE)	616 SF		
0007	4410000000-E	1110	WORK ZONE SIGNS (BARRICADE MOUNTED)	22 SF		
0008	4415000000-N	1115	FLASHING ARROW BOARD	2 EA		
0009	4422000000-N	1120	PORTABLE CHANGEABLE MESSAGE SIGN (SHORT TERM)	180 DAY		
0010	4430000000-N	1130	DRUMS	55 EA		
0011	4434000000-N	1140	SEQUENTIAL FLASHING WARNING LIGHTS	16 EA		
0012	4435000000-N	1135	CONES	58 EA		
0013	4445000000-E	1145	BARRICADES (TYPE III)	16 LF		
0014	4455000000-N	1150	FLAGGER	180 DAY		
0015	4480000000-N	1165	TMA	1 EA		
0016	4510000000-N	1190	LAW ENFORCEMENT	304 HR		
0017	4846000000-E	1205	POLYUREA PAVEMENT MARKING LINES (***, *** MILS) (4", 20 MILS)	3,699 LF		



County: CHATHAM, MOORE

Line #	Item Number	Sec #	Description	Quantity	Unit Cost	Amount
0018	4846000000-E	1205	POLYUREA PAVEMENT MARKING LINES (***, *** MILS) (6", 20 MILS)	4,085 LF		
0019	4900000000-N	1251	PERMANENT RAISED PAVEMENT MARKERS	30 EA		
0020	5255000000-N	1413	PORTABLE LIGHTING	Lump Sum	L.S.	
<b>STRUCTURE ITEMS</b>						
0021	8161000000-E	420	GROOVING BRIDGE FLOORS	92,786.3 SF		
0022	8296000000-N	442	POLLUTION CONTROL	Lump Sum	L.S.	
0023	8559000000-E	SP	CLASS II, SURFACE PREPARATION	218.7 SY		
0024	8660000000-E	SP	CONCRETE REPAIRS	69.4 CF		
0025	8664000000-E	SP	SHOTCRETE REPAIRS	439.7 CF		
0026	8678000000-E	SP	EPOXY RESIN INJECTION	448 LF		
0027	8860000000-N	SP	GENERIC STRUCTURE ITEM DRIFT REMOVAL	Lump Sum	L.S.	
0028	8860000000-N	SP	GENERIC STRUCTURE ITEM PAINTING CONTAINMENT FOR BRIDGE #620049	Lump Sum	L.S.	
0029	8860000000-N	SP	GENERIC STRUCTURE ITEM PAINTING CONTAINMENT FOR ZONE PAINTING	Lump Sum	L.S.	
0030	8860000000-N	SP	GENERIC STRUCTURE ITEM ZONE PAINTING OF EXISTING STRUCTURE	Lump Sum	L.S.	
0031	8867000000-E	SP	GENERIC STRUCTURE ITEM FOAM JOINT SEALS FOR PRESERVATION	1,017 LF		
0032	8881000000-E	SP	GENERIC STRUCTURE ITEM LATEX MODIFIED CONCRETE OVERLAY - VERY EARLY STRENGTH	136 CY		

County: CHATHAM, MOORE

Line #	Item Number	Sec #	Description	Quantity	Unit Cost	Amount
0033	8882000000-E	SP	GENERIC STRUCTURE ITEM ELASTOMERIC CONCRETE FOR PRESERVATION	100.7 CF		
0034	8882000000-E	SP	GENERIC STRUCTURE ITEM REPAIRS FOR PRESTRESSED CONCRETE GIRDERS	12.3 CF		
0035	8892000000-E	SP	GENERIC STRUCTURE ITEM BRIDGE JOINT DEMOLITION	280 SF		
0036	8892000000-E	SP	GENERIC STRUCTURE ITEM EPOXY COATING	5,267.9 SF		
0037	8892000000-E	SP	GENERIC STRUCTURE ITEM SILANE BARRIER RAIL TREATMENT	11,731 SF		
0038	8892000000-E	SP	GENERIC STRUCTURE ITEM SURFACE PREPARATION FOR SILANE BARRIER RAIL TREATMENT	11,731 SF		
0039	8893000000-E	SP	GENERIC STRUCTURE ITEM CONCRETE DECK REPAIR FOR POLYMER CONCRETE OVERLAY	71.5 SY		
0040	8893000000-E	SP	GENERIC STRUCTURE ITEM HYDRO-DEMOLITION OF BRIDGE DECK	3,255.6 SY		
0041	8893000000-E	SP	GENERIC STRUCTURE ITEM PLACING AND FINISHING OF LATEX MODIFIED CONCRETE OVERLAY - VERY EARLY STRENGTH	3,255.6 SY		
0042	8893000000-E	SP	GENERIC STRUCTURE ITEM PLACING AND FINISHING POLYMER CONCRETE OVERLAY	8,009.8 SY		
0043	8893000000-E	SP	GENERIC STRUCTURE ITEM SCARIFYING BRIDGE DECK	11,265.4 SY		
0044	8893000000-E	SP	GENERIC STRUCTURE ITEM SHOTBLASTING BRIDGE DECK	8,009.8 SY		
0045	8897000000-N	SP	GENERIC STRUCTURE ITEM CLEANING AND PAINTING EXISTING BEARINGS WITH HRCS	48 EA		
0046	8897000000-N	SP	GENERIC STRUCTURE ITEM TYPE I BRIDGE JACKING BRIDGE #620049	6 EA		
0047	8897000000-N	SP	GENERIC STRUCTURE ITEM TYPE I BRIDGE JACKING BRIDGE #620072	1 EA		

County: CHATHAM, MOORE

Line #	Item Number	Sec #	Description	Quantity	Unit Cost	Amount
***** BEGIN SCHEDULE AA ***** ***** ( 2 ALTERNATES ) *****						
0048 AA1	8881000000-E	SP	GENERIC STRUCTURE ITEM POLYESTER POLYMER CONCRETE MATERIALS	222.5	CY	
*** OR ***						
0049 AA2	8881000000-E	SP	GENERIC STRUCTURE ITEM EPOXY POLYMER CONCRETE MATERIALS	222.5	CY	
**** END SCHEDULE AA ****						
1431/May13/Q168449.7/D332865100000/E49			Total Amount Of Bid For Entire Project :			

## Vendor 1 of 6: FREYSSINET INC (5447) Call Order 008 (Proposal: C204455)

### Bid Information

---

<b>Proposal County:</b> CHATHAM MOORE	<b>Bid Checksum:</b> 969E266CC9
<b>Vendor Address:</b> 44880 FALCON PLACE SUITE 100 STERLING , VA , 20166	<b>Bid Total:</b> \$6,392,193.80
<b>Signature Check:</b> Michael, Bernard LOUIS	<b>Items Total:</b> \$6,392,193.80
<b>Time Bid Received:</b> June 18, 2024 01:54 PM	<b>Time Total:</b> \$0.00
<b>Amendment Count:</b> 0	

**Bidding Errors:**  
None.

Vendor 1 of 6: FREYSSINET INC (5447)  
Call Order 008 (Proposal: C204455)

Bid Bond Information

---

<b>Projects:</b>	<b>Bond Maximum:</b>
<b>Counties:</b>	<b>State of Incorporation:</b> SD
<b>Bond ID:</b> A211-EEAB-5F3D-7CFD	<b>Agency Execution Date:</b> 2024-06-10T00:00:00
<b>Paid by Check:</b> No	<b>Surety Name:</b> Tinubu Surety
<b>Bond Percent:</b> 5%	<b>Bond Agency Name:</b> Western Surety Company

### DBE Load Information

Letting ID: L240618

Letting Date: 06/18/2024

Call Order: 008

Contract ID: C204455

Project: STATE FUNDEDSTATE FUNDEDSTATE FUNDEDSTATE FUNDED

Bid Total: \$6,392,193.80

DBE Goal: 1.00% (\$63,921.94)

Vendor ID: 5447

Vendor Name: Freyssinet Inc

DBE Entered: 1.01% (\$64,626.00)

Vendor ID	DBE Name	Is Supplier?	City/State	Goods/Service	Amount
4761	TRAFFIC CONTROL SAFETY SERVICES INC	False	P.O. Box 24511 WINSTON SALEM, NC 27114	SubContractor	64,626.00

BondID: A211-EEAB-5F3D-7CFD  
Surety Registry Agency: Tinubu Surety  
Verified?: 1  
Surety Agency: Western Surety Company  
Bond Execution Date: 2024-06-10T00:00:00

Line Number	Item Number	Quantity	Unit	Unit Price	Extension Price
Section 0001 ROADWAY ITEMS					
0001	0000100000-N MOBILIZATION	1.000	LS	\$319,500.0000	\$319,500.00
0002	1330000000-E INCIDENTAL MILLING	312.000	SY	\$14.2000	\$4,430.40
0003	1523000000-E ASPHALT CONC SURFACE COURSE, TYPE S9.5C	26.400	TON	\$283.0000	\$7,471.20
0004	1575000000-E ASPHALT BINDER FOR PLANT MIX	1.600	TON	\$906.0000	\$1,449.60
0005	4400000000-E WORK ZONE SIGNS (STATIONARY)	233.000	SF	\$29.0000	\$6,757.00
0006	4405000000-E WORK ZONE SIGNS (PORTABLE)	616.000	SF	\$19.0000	\$11,704.00
0007	4410000000-E WORK ZONE SIGNS (BARRICADE MOUNTED)	22.000	SF	\$20.0000	\$440.00
0008	4415000000-N FLASHING ARROW BOARD	2.000	EA	\$9,990.0000	\$19,980.00
0009	4422000000-N PORTABLE CHANGEABLE MESSAGE SIGN (SHORT TERM)	180.000	DAY	\$84.9000	\$15,282.00
0010	4430000000-N DRUMS	55.000	EA	\$96.0000	\$5,280.00
0011	4434000000-N SEQUENTIAL FLASHING WARNING LIGHTS	16.000	EA	\$188.0000	\$3,008.00
0012	4435000000-N CONES	58.000	EA	\$45.0000	\$2,610.00
0013	4445000000-E BARRICADES (TYPE III)	16.000	LF	\$79.0000	\$1,264.00
0014	4455000000-N FLAGGER	180.000	DAY	\$236.0000	\$42,480.00
0015	4480000000-N TMA	1.000	EA	\$50,950.0000	\$50,950.00
0016	4510000000-N LAW ENFORCEMENT	304.000	HR	\$45.0000	\$13,680.00
0017	4846000000-E POLYUREA PAVEMENT MARKING LINES (**", ** MILS) (4", 20 MILS)	3699.000	LF	\$4.0000	\$14,796.00
0018	4846000000-E POLYUREA PAVEMENT MARKING LINES (**", ** MILS) (6", 20 MILS)	4085.000	LF	\$4.5000	\$18,382.50
0019	4900000000-N PERMANENT RAISED PAVEMENT MARKERS	30.000	EA	\$52.0000	\$1,560.00
0020	5255000000-N PORTABLE LIGHTING	1.000	LS	\$58,250.0000	\$58,250.00

Section 0001 Total \$599,274.70

Section 0004  
STRUCTURE ITEMS

0021	8161000000-E	92786.300	SF	\$1.0000	\$92,786.30
------	--------------	-----------	----	----------	-------------



GROOVING BRIDGE FLOORS

0022	8296000000-N	1.000 LS	\$117,600.0000	\$117,600.00
	POLLUTION CONTROL			
0023	8559000000-E	218.700 SY	\$565.0000	\$123,565.50
	CLASS II, SURFACE PREPARATION			
0024	8660000000-E	69.400 CF	\$1,100.0000	\$76,340.00
	CONCRETE REPAIRS			
0025	8664000000-E	439.700 CF	\$1,100.0000	\$483,670.00
	SHOTCRETE REPAIRS			
0026	8678000000-E	448.000 LF	\$125.0000	\$56,000.00
	EPOXY RESIN INJECTION			
0027	8860000000-N	1.000 LS	\$181,500.0000	\$181,500.00
	GENERIC STRUCTURE ITEM DRIFT REMOVAL			
0028	8860000000-N	1.000 LS	\$58,800.0000	\$58,800.00
	GENERIC STRUCTURE ITEM PAINTING CONTAINMENT FOR BRIDGE #620049			
0029	8860000000-N	1.000 LS	\$156,700.0000	\$156,700.00
	GENERIC STRUCTURE ITEM PAINTING CONTAINMENT FOR ZONE PAINTING			
0030	8860000000-N	1.000 LS	\$431,000.0000	\$431,000.00
	GENERIC STRUCTURE ITEM ZONE PAINTING OF EXISTING STRUCTURE			
0031	8867000000-E	1017.000 LF	\$124.0000	\$126,108.00
	GENERIC STRUCTURE ITEM FOAM JOINT SEALS FOR PRESERVATION			
0032	8881000000-E	136.000 CY	\$2,500.0000	\$340,000.00
	GENERIC STRUCTURE ITEM LATEX MODIFIED CONCRETE OVERLAY - VERY EARLY STRENGTH			
0033	8882000000-E	100.700 CF	\$682.0000	\$68,677.40
	GENERIC STRUCTURE ITEM ELASTOMERIC CONCRETE FOR PRESERVATION			
0034	8882000000-E	12.300 CF	\$1,250.0000	\$15,375.00
	GENERIC STRUCTURE ITEM REPAIRS FOR PRESTRESSED CONCRETE GIRDERS			
0035	8892000000-E	280.000 SF	\$167.0000	\$46,760.00
	GENERIC STRUCTURE ITEM BRIDGE JOINT DEMOLITION			
0036	8892000000-E	5267.900 SF	\$11.0000	\$57,946.90
	GENERIC STRUCTURE ITEM EPOXY COATING			
0037	8892000000-E	11731.000 SF	\$3.5000	\$41,058.50
	GENERIC STRUCTURE ITEM SILANE BARRIER RAIL TREATMENT			
0038	8892000000-E	11731.000 SF	\$2.0000	\$23,462.00
	GENERIC STRUCTURE ITEM SURFACE PREPARATION FOR SILANE BARRIER RAIL TREATMENT			
0039	8893000000-E	71.500 SY	\$809.0000	\$57,843.50
	GENERIC STRUCTURE ITEM CONCRETE DECK REPAIR FOR POLYMER CONCRETE OVERLAY			
0040	8893000000-E	3255.600 SY	\$110.0000	\$358,116.00
	GENERIC STRUCTURE ITEM HYDRO-DEMOLITION OF BRIDGE DECK			
0041	8893000000-E	3255.600 SY	\$130.0000	\$423,228.00
	GENERIC STRUCTURE ITEM PLACING AND FINISHING OF LATEX MODIFIED CONCRETE OVERLAY - VERY EARLY STRENGTH			
0042	8893000000-E	8009.800 SY	\$120.0000	\$961,176.00
	GENERIC STRUCTURE ITEM PLACING AND FINISHING POLYMER CONCRETE OVERLAY			
0043	8893000000-E	11265.400 SY	\$25.0000	\$281,635.00
	GENERIC STRUCTURE ITEM SCARIFYING BRIDGE DECK			
0044	8893000000-E	8009.800 SY	\$20.0000	\$160,196.00
	GENERIC STRUCTURE ITEM SHOTBLASTING BRIDGE DECK			
0045	8897000000-N	48.000 EA	\$3,500.0000	\$168,000.00

GENERIC STRUCTURE ITEM CLEANING AND PAINTING EXISTING BEARINGS WITH HRCS

0046	8897000000-N	6.000 EA	\$20,000.0000	\$120,000.00
	GENERIC STRUCTURE ITEM TYPE I BRIDGE JACKING BRIDGE #620049			
0047	8897000000-N	1.000 EA	\$20,000.0000	\$20,000.00
	GENERIC STRUCTURE ITEM TYPE I BRIDGE JACKING BRIDGE #620072			
0048	8881000000-E	222.500 CY	\$3,350.0000	\$745,375.00
AA1	GENERIC STRUCTURE ITEM POLYESTER POLYMER CONCRETE MATERIALS			
0049	8881000000-E	222.500 CY		
AA2	GENERIC STRUCTURE ITEM EPOXY POLYMER CONCRETE MATERIALS			
Section 0004 Total				\$5,792,919.10
Item Total				\$6,392,193.80

**ELECTRONIC BID SUBMISSION**

By submitting this bid electronically, I hereby acknowledge that all requirements included in the hard copy proposal, addendum, amendments, plans, standard specifications, supplemental specifications and special provisions are part of the bid and contract. Further, I acknowledge that I have read, understand, accept, acknowledge and agree to comply with all statements in this electronic bid.

=====

**NON-COLLUSION, DEBARMENT AND GIFT BAN CERTIFICATION**

The prequalified bidder declares (or certifies, verifies, or states) under penalty of perjury under the laws of the United States that neither he, nor any official, agent or employee has entered into any agreement, participated in any collusion, or otherwise taken any action which is in restraint of free competitive bidding in connection with any bid or contract, that the prequalified bidder has not been convicted of violating N.C.G.S. §133-24 within the last three years, and that the prequalified bidder intends to do the work with his own bonafide employees or subcontractors and will not bid for the benefit of another contractor.

By submitting this non-collusion, debarment and gift ban certification, the Contractor is attesting his status under penalty of perjury under the laws of the United States in accordance with the Debarment Certification attached, provided that the Debarment Certification also includes any required statements concerning exceptions that are applicable.

N.C.G.S. §133-32 and Executive Order 24 prohibit the offer to, or acceptance by, any State Employee of any gift from anyone with a contract with the State, or from any person seeking to do business with the State. By execution of any response in this procurement, you attest, for your entire organization and its employees or agents, that you are not aware that any such gift has been offered, accepted, or promised by any employees of your organization.

**DEBARMENT CERTIFICATION OF PREQUALIFIED BIDDER**

Conditions for certification:

1. The prequalified bidder shall provide immediate written notice to the Department if at any time the bidder learns that his certification was erroneous when he submitted his debarment certification or explanation that is file with the Department, or has become erroneous because of changed circumstances.
2. The terms covered transaction, debarred, suspended, ineligible, lower tier

covered transaction, participant, person, primary covered transaction, principal, proposal, and voluntarily excluded, as used in this provision, have the meanings set out in the Definitions and Coverage sections of the rules implementing Executive Order 12549. A copy of the Federal Rules requiring this certification and detailing the definitions and coverages may be obtained from the Contract Officer of the Department.

3. The prequalified bidder agrees by submitting this form, that he will not knowingly enter into any lower tier covered transaction with a person who is debarred, suspended, declared ineligible, or voluntarily excluded from participation in NCDOT contracts, unless authorized by the Department.

4. For Federal Aid projects, the prequalified bidder further agrees that by submitting this form he will include the Federal- Aid Provision titled Required Contract Provisions Federal-Aid Construction Contract (Form FHWA PR 1273) provided by the Department, without subsequent modification, in all lower tier covered transactions.

5. The prequalified bidder may rely upon a certification of a participant in a lower tier covered transaction that he is not debarred, suspended, ineligible, or voluntarily excluded from the covered transaction, unless he knows that the certification is erroneous. The bidder may decide the method and frequency by which he will determine the eligibility of his subcontractors.

6. Nothing contained in the foregoing shall be construed to require establishment of a system of records in order to render in good faith the certification required by this provision. The knowledge and information of a participant is not required to exceed that which is normally possessed by a prudent person in the ordinary course of business dealings.

7. Except as authorized in paragraph 6 herein, the Department may terminate any contract if the bidder knowingly enters into a lower tier covered transaction with a person who is suspended, debarred, ineligible, or voluntarily excluded from participation in this transaction, in addition to other remedies available by the Federal Government.

### **DEBARMENT CERTIFICATION**

The prequalified bidder certifies to the best of his knowledge and belief, that he and his principals:

a. Are not presently debarred, suspended, proposed for debarment, declared ineligible, or voluntarily excluded from covered transactions by any Federal department or agency;

b. Have not within a three-year period preceding this proposal been convicted of or had a civil judgment rendered against them for commission of fraud or a criminal offense in connection with obtaining, attempting to obtain, or performing a public (Federal, State or local) transaction or contract under a public transaction; violation of Federal or State antitrust statutes or

commission of embezzlement, theft, forgery, bribery, falsification or destruction of records; making false statements; or receiving stolen property;

c. Are not presently indicted for or otherwise criminally or civilly charged by a governmental entity (Federal, State or local) with commission of any of the offenses enumerated in paragraph b. of this certification; and

d. Have not within a three-year period preceding this proposal had one or more public transactions (Federal, State or local) terminated for cause or default.

e. Will submit a revised Debarment Certification immediately if his status changes and will show in his bid proposal an explanation for the change in status.

If the prequalified bidder cannot certify that he is not debarred, he shall provide an explanation with this submittal. An explanation will not necessarily result in denial of participation in a contract.

Failure to submit a non-collusion and debarment certification will result in the prequalified bidder's bid being considered non-responsive.

**EXPLANATION:**

=====

### Award Limits on Multiple Projects

By answering YES to this statement, the bidder acknowledges that they are using the award limits on multiple projects? **Yes**  **No**

A bidder who desires to bid on more than one project on which bids are to be opened on the same date, and who also desires to avoid receiving an award of more projects than he is equipped to handle, may bid on any number of projects but may limit the total amount of work awarded to him on selected projects by completing the AWARD LIMITS ON MULTIPLE PROJECTS.

The Award Limits on Multiple Projects must be filled in on each project bid for which the Bidder desires protection.

It is the desire of the Bidder to be awarded contracts, the value of which will not exceed a total of     for those

projects indicated herein, for which bids will be opened on     (MM/DD/YY)

The Award Limits shall apply to the following projects:

Contract Number  
County

Contract Number  
County

Contract Number  
County

Contract Number  
County

Contract Number  
County

Contract Number  
County

It is agreed that if I am (we are) the low Bidder(s) on indicated projects, the total value of which is more than the above stipulated award limits, the Board of Transportation will award me (us) projects from among those indicated

that have a total value not to exceed the award limit and will result in the lowest total bids to the Department of Transportation.

## DBE List Summary

Project: STATE FUNDED  
Bid Total: 6,392,193.80  
Goal: 1.00% (63,921.94)  
Total Entered: 1.01% (64,626.00)

Bidder ID: 5447  
Business Name: Freyssinet Inc

ID	Name	Is Supplier?	Item Count	Amount	Is Complete?
4761	TRAFFIC CONTROL SAFETY SERVICES INC	False	10	64,626.00	True



Name: TRAFFIC CONTROL SAFETY SERVICES INC ID: 4761

Address: P.O. Box 24511 WINSTON SALEM, NC 27114

Used As: SubContractor DBE Items Total:\$64,626.00

**Items for TRAFFIC CONTROL SAFETY SERVICES INC**

0001 ROADWAY ITEMS					
0005	4400000000-E	233.000	SF	\$15.0000	\$3,495.00
	WORK ZONE SIGNS (STATIONARY)				
0006	4405000000-E	616.000	SF	\$9.7500	\$6,006.00
	WORK ZONE SIGNS (PORTABLE)				
0007	4410000000-E	22.000	SF	\$10.0000	\$220.00
	WORK ZONE SIGNS (BARRICADE MOUNTED)				
0008	4415000000-N	2.000	EA	\$5,100.0000	\$10,200.00
	FLASHING ARROW BOARD				
0009	4422000000-N	180.000	DAY	\$75.0000	\$13,500.00
	PORTABLE CHANGEABLE MESSAGE SIGN (SHORT TERM)				
0010	4430000000-N	55.000	EA	\$49.0000	\$2,695.00
	DRUMS				
0011	4434000000-N	16.000	EA	\$96.0000	\$1,536.00
	SEQUENTIAL FLASHING WARNING LIGHTS				
0012	4435000000-N	58.000	EA	\$23.0000	\$1,334.00
	CONES				
0013	4445000000-E	16.000	LF	\$40.0000	\$640.00
	BARRICADES (TYPE III)				
0015	4480000000-N	1.000	EA	\$25,000.0000	\$25,000.00
	TMA				
Section 0001 Total					\$64,626.00
Item Total					\$64,626.00

THIS PROPOSAL CONTAINS THE FOLLOWING ERRORS/WARNINGS (IF ANY)

This Bid contains 0 amendment files

**Electronic Bid Submission**

By submitting this bid electronically, I hereby acknowledge that all requirements included in the hard copy proposal, addendum, amendments, plans, standard specifications, supplemental specifications and special provisions are part of the bid and contract. Further, I acknowledge that I have read, understand, accept, acknowledge and agree to comply with all statements in this electronic bid.

I hereby certify that I have the authority to submit this bid.

Signature \_\_\_\_\_

Agency \_\_\_\_\_

Date \_\_\_\_\_

Signature \_\_\_\_\_

Agency \_\_\_\_\_

Date \_\_\_\_\_

Signature \_\_\_\_\_

Agency \_\_\_\_\_

Date \_\_\_\_\_

## Attachments

Failure to complete and attach the Fuel Usage Factor Adjustment Form will result in using 2.90 gallons per ton as the Fuel Usage Factor for Diesel for the asphalt items included on the form. The contractor will not be permitted to change the option after the bids are submitted.

NOTE: The maximum upload limit is 5 MB.

Verify

Line #	ItemNumber	Sec #	Description	Quantity Unit	Unit Bid Price	Amount Bid
<b>ROADWAY ITEMS</b>						
0001	0000100000-N	800	MOBILIZATION	LUMP SUM	319,500.00	319,500.00
0002	1330000000-E	607	INCIDENTAL MILLING	312 SY	14.20	4,430.40
0003	1523000000-E	610	ASPHALT CONC SURFACE COURSE, TYPE S9.5C	26.4 TON	283.00	7,471.20
0004	1575000000-E	620	ASPHALT BINDER FOR PLANT MIX	1.6 TON	906.00	1,449.60
0005	4400000000-E	1110	WORK ZONE SIGNS (STATIONARY)	233 SF	29.00	6,757.00
0006	4405000000-E	1110	WORK ZONE SIGNS (PORTABLE)	616 SF	19.00	11,704.00
0007	4410000000-E	1110	WORK ZONE SIGNS (BARRICADE MOUNTED)	22 SF	20.00	440.00
0008	4415000000-N	1115	FLASHING ARROW BOARD	2 EA	9,990.00	19,980.00
0009	4422000000-N	1120	PORTABLE CHANGEABLE MESSAGE SIGN (SHORT TERM)	180 DAY	84.90	15,282.00
0010	4430000000-N	1130	DRUMS	55 EA	96.00	5,280.00
0011	4434000000-N	1140	SEQUENTIAL FLASHING WARNING LIGHTS	16 EA	188.00	3,008.00
0012	4435000000-N	1135	CONES	58 EA	45.00	2,610.00
0013	4445000000-E	1145	BARRICADES (TYPE III)	16 LF	79.00	1,264.00
0014	4455000000-N	1150	FLAGGER	180 DAY	236.00	42,480.00
0015	4480000000-N	1165	TMA	1 EA	50,950.00	50,950.00
0016	4510000000-N	1190	LAW ENFORCEMENT	304 HR	45.00	13,680.00
0017	4846000000-E	1205	POLYUREA PAVEMENT MARKING LINES (***, ***) MILS) (4", 20 MILS)	3,699 LF	4.00	14,796.00
0018	4846000000-E	1205	POLYUREA PAVEMENT MARKING LINES (***, ***) MILS) (6", 20 MILS)	4,085 LF	4.50	18,382.50
0019	4900000000-N	1251	PERMANENT RAISED PAVEMENT MARKERS	30 EA	52.00	1,560.00
0020	5255000000-N	1413	PORTABLE LIGHTING	LUMP SUM	58,250.00	58,250.00

Line #	ItemNumber	Sec #	Description	Quantity Unit	Unit Bid Price	Amount Bid
STRUCTURE ITEMS						
0021	8161000000-E	420	GROOVING BRIDGE FLOORS	92,786.3 SF	1.00	92,786.30
0022	8296000000-N	442	POLLUTION CONTROL	LUMP SUM	117,600.00	117,600.00
0023	8559000000-E	SP	CLASS II, SURFACE PREPARATION	218.7 SY	565.00	123,565.50
0024	8660000000-E	SP	CONCRETE REPAIRS	69.4 CF	1,100.00	76,340.00
0025	8664000000-E	SP	SHOTCRETE REPAIRS	439.7 CF	1,100.00	483,670.00
0026	8678000000-E	SP	EPOXY RESIN INJECTION	448 LF	125.00	56,000.00
0027	8860000000-N	SP	GENERIC STRUCTURE ITEM DRIFT REMOVAL	LUMP SUM	181,500.00	181,500.00
0028	8860000000-N	SP	GENERIC STRUCTURE ITEM PAINTING CONTAINMENT FOR BRIDGE #620049	LUMP SUM	58,800.00	58,800.00
0029	8860000000-N	SP	GENERIC STRUCTURE ITEM PAINTING CONTAINMENT FOR ZONE PAINTING	LUMP SUM	156,700.00	156,700.00
0030	8860000000-N	SP	GENERIC STRUCTURE ITEM ZONE PAINTING OF EXISTING STRUCTURE	LUMP SUM	431,000.00	431,000.00
0031	8867000000-E	SP	GENERIC STRUCTURE ITEM FOAM JOINT SEALS FOR PRESERVATION	1,017 LF	124.00	126,108.00
0032	8881000000-E	SP	GENERIC STRUCTURE ITEM LATEX MODIFIED CONCRETE OVERLAY - VERY EARLY STRENGTH	136 CY	2,500.00	340,000.00
0033	8882000000-E	SP	GENERIC STRUCTURE ITEM ELASTOMERIC CONCRETE FOR PRESERVATION	100.7 CF	682.00	68,677.40
0034	8882000000-E	SP	GENERIC STRUCTURE ITEM REPAIRS FOR PRESTRESSED CONCRETE GIRDERS	12.3 CF	1,250.00	15,375.00
0035	8892000000-E	SP	GENERIC STRUCTURE ITEM BRIDGE JOINT DEMOLITION	280 SF	167.00	46,760.00
0036	8892000000-E	SP	GENERIC STRUCTURE ITEM EPOXY COATING	5,267.9 SF	11.00	57,946.90
0037	8892000000-E	SP	GENERIC STRUCTURE ITEM SILANE BARRIER RAIL TREATMENT	11,731 SF	3.50	41,058.50
0038	8892000000-E	SP	GENERIC STRUCTURE ITEM SURFACE PREPARATION FOR SILANE BARRIER RAIL TREATMENT	11,731 SF	2.00	23,462.00

Contract Item Sheets For C204455

Line #	ItemNumber	Sec #	Description	Quantity Unit	Unit Bid Price	Amount Bid
0039	8893000000-E	SP	GENERIC STRUCTURE ITEM CONCRETE DECK REPAIR FOR POLYMER CONCRETE OVERLAY	71.5 SY	809.00	57,843.50
0040	8893000000-E	SP	GENERIC STRUCTURE ITEM HYDRO-DEMOLITION OF BRIDGE DECK	3,255.6 SY	110.00	358,116.00
0041	8893000000-E	SP	GENERIC STRUCTURE ITEM PLACING AND FINISHING OF LATEX MODIFIED CONCRETE OVERLAY - VERY EARLY STRENGTH	3,255.6 SY	130.00	423,228.00
0042	8893000000-E	SP	GENERIC STRUCTURE ITEM PLACING AND FINISHING POLYMER CONCRETE OVERLAY	8,009.8 SY	120.00	961,176.00
0043	8893000000-E	SP	GENERIC STRUCTURE ITEM SCARIFYING BRIDGE DECK	11,265.4 SY	25.00	281,635.00
0044	8893000000-E	SP	GENERIC STRUCTURE ITEM SHOTBLASTING BRIDGE DECK	8,009.8 SY	20.00	160,196.00
0045	8897000000-N	SP	GENERIC STRUCTURE ITEM CLEANING AND PAINTING EXISTING BEARINGS WITH HRCS	48 EA	3,500.00	168,000.00
0046	8897000000-N	SP	GENERIC STRUCTURE ITEM TYPE I BRIDGE JACKING BRIDGE #620049	6 EA	20,000.00	120,000.00
0047	8897000000-N	SP	GENERIC STRUCTURE ITEM TYPE I BRIDGE JACKING BRIDGE #620072	1 EA	20,000.00	20,000.00
***** BEGIN SCHEDULE AA *****						
***** ( 2 ALTERNATES ) *****						
0048 AA1	8881000000-E	SP	GENERIC STRUCTURE ITEM POLYESTER POLYMER CONCRETE MATERIALS	222.5 CY		745,375.00
*** OR ***						
0049 AA2	8881000000-E	SP	GENERIC STRUCTURE ITEM EPOXY POLYMER CONCRETE MATERIALS	222.5 CY		
*** END SCHEDULE AA ***						
TOTAL AMOUNT OF BID FOR ENTIRE PROJECT						\$6,392,193.80

Contract No. C204455

Rev. 1-16-18

County Chatham, Moore

Chatham, Moore

**EXECUTION OF CONTRACT  
NON-COLLUSION, DEBARMENT AND GIFT BAN CERTIFICATION**

**CORPORATION**

The Contractor declares (or certifies, verifies, or states) under penalty of perjury under the laws of the United States that neither he, nor any official, agent or employee has entered into any agreement, participated in any collusion, or otherwise taken any action which is in restraint of free competitive bidding in connection with this Contract, that the Contractor has not been convicted of violating *N.C.G.S. § 133-24* within the last three years, and that the Contractor intends to do the work with its own bona fide employees or subcontractors and did not bid for the benefit of another contractor.

By submitting this Execution of Contract, Non-Collusion and Debarment Certification, the Contractor is certifying his status under penalty of perjury under the laws of the United States in accordance with the Debarment Certification attached, provided that the Debarment Certification also includes any required statements concerning exceptions that are applicable.

*N.C.G.S. § 133-32* and Executive Order 24 prohibit the offer to, or acceptance by, any State Employee of any gift from anyone with a contract with the State, or from any person seeking to do business with the State. By execution of any response in this procurement, you attest, for your entire organization and its employees or agents, that you are not aware that any such gift has been offered, accepted, or promised by any employees of your organization.

**SIGNATURE OF CONTRACTOR**

Freyssinet, Inc

Full name of Corporation

44880 Falcon Place, Suite 100. Sterling. VA 20166

Address as Prequalified

Attest

  
Secretary/Assistant Secretary  
Select appropriate title

By

  
President/Vice President/Assistant Vice President  
Select appropriate title

Raphael Mantion

Print or type Signer's name

Michael Louis

Print or type Signer's name

**CORPORATE SEAL**



## DEBARMENT CERTIFICATION

### Conditions for certification:

1. The prequalified bidder shall provide immediate written notice to the Department if at any time the bidder learns that his certification was erroneous when he submitted his debarment certification or explanation filed with the Department, or has become erroneous because of changed circumstances.
2. The terms *covered transaction, debarred, suspended, ineligible, lower tier covered transaction, participant, person, primary covered transaction, principal, proposal, and voluntarily excluded*, as used in this provision, have the meanings set out in the Definitions and Coverage sections of the rules implementing Executive Order 12549. A copy of the Federal Rules requiring this certification and detailing the definitions and coverages may be obtained from the Contract Officer of the Department.
3. The prequalified bidder agrees by submitting this form, that he will not knowingly enter into any lower tier covered transaction with a person who is debarred, suspended, declared ineligible, or voluntarily excluded from participation in NCDOT contracts, unless authorized by the Department.
4. For Federal Aid projects, the prequalified bidder further agrees that by submitting this form he will include the Federal-Aid Provision titled *Required Contract Provisions Federal-Aid Construction Contract (Form FHWA PR 1273)* provided by the Department, without subsequent modification, in all lower tier covered transactions.
5. The prequalified bidder may rely upon a certification of a participant in a lower tier covered transaction that he is not debarred, suspended, ineligible, or voluntarily excluded from the covered transaction, unless he knows that the certification is erroneous. The bidder may decide the method and frequency by which he will determine the eligibility of his subcontractors.
6. Nothing contained in the foregoing shall be construed to require establishment of a system of records in order to render in good faith the certification required by this provision. The knowledge and information of a participant is not required to exceed that which is normally possessed by a prudent person in the ordinary course of business dealings.
7. Except as authorized in paragraph 6 herein, the Department may terminate any contract if the bidder knowingly enters into a lower tier covered transaction with a person who is suspended, debarred, ineligible, or voluntarily excluded from participation in this transaction, in addition to other remedies available by the Federal Government.



Contract No. C204455

Rev. 1-16-18

County Chatham, Moore

Chatham, Moore

### DEBARMENT CERTIFICATION

The prequalified bidder certifies to the best of his knowledge and belief, that he and his principals:

- a. Are not presently debarred, suspended, proposed for debarment, declared ineligible, or voluntarily excluded from covered transactions by any Federal department or agency;
- b. Have not within a three-year period preceding this proposal been convicted of or had a civil judgment rendered against them for commission of fraud or a criminal offense in connection with obtaining, attempting to obtain, or performing a public (Federal, State or local) transaction or contract under a public transaction; violation of Federal or State antitrust statutes or commission of embezzlement, theft, forgery, bribery, falsification or destruction of records; making false statements; or receiving stolen property;
- c. Are not presently indicted for or otherwise criminally or civilly charged by a governmental entity (Federal, State or local) with commission of any of the offenses enumerated in paragraph b. of this certification; and
- d. Have not within a three-year period preceding this proposal had one or more public transactions (Federal, State or local) terminated for cause or default.
- e. Will submit a revised Debarment Certification immediately if his status changes and will show in his bid proposal an explanation for the change in status.

If the prequalified bidder cannot certify that he is not debarred, he shall provide an explanation with this submittal. An explanation will not necessarily result in denial of participation in a contract.

Failure to submit a non-collusion and debarment certification will result in the prequalified bidder's bid being considered non-responsive.

Check here if an explanation is attached to this certification.

**Contract No.**     **C204455**

**County (ies):**     **Chatham, Moore**

ACCEPTED BY THE  
DEPARTMENT OF TRANSPORTATION

DocuSigned by:

*Ronald E. Davenport, Jr.*

52C46046381F443...

Contract Officer

07/09/2024

Date

Execution of Contract and Bonds  
Approved as to Form:

DocuSigned by:

*Justin Bradley*

B211A5422113486...

Attorney General

07/09/2024

Date

Signature Sheet (Bid - Acceptance by Department)

**CONTRACT PAYMENT BOND**

Date of Payment Bond Execution July 3, 2024

Name of Principal Contractor Freyssinet Inc.

Name of Surety: Western Surety Company/Bond No. 30217046

Name of Contracting Body: North Carolina Department of Transportation  
Raleigh, North Carolina

Amount of Bond: \$6,392,193.80

Contract ID No.: C204455

County Name: Chatham, Moore

KNOW ALL MEN BY THESE PRESENTS, That we, the PRINCIPAL CONTRACTOR (hereafter, PRINCIPAL) and SURETY above named, are held and firmly bound unto the above named Contracting Body, hereinafter called the Contracting Body, in the penal sum of the amount stated above for the payment of which sum well and truly to be made, we bind ourselves, our heirs, executors, administrators, and successors, jointly and severally, firmly by these presents.

THE CONDITION OF THIS OBLIGATION IS SUCH, that whereas the principal entered into a certain contract with the Contracting Body, numbered as shown above and hereto attached:

NOW THEREFORE, if the principal shall promptly make payment to all persons supplying labor and material in the prosecution of the work provided for in said contract, and any and all duly authorized modifications of said contract that may hereafter be made, notice of which modifications to the surety being hereby waived, then this obligation to be void; otherwise to remain in full force and virtue.

IN WITNESS WHEREOF, the above-bound parties have executed this instrument under their several seals on the date indicated above, the name and corporate seal of each corporate party being hereto affixed and these presents duly signed by its undersigned representative, pursuant to authority of its governing body.

Contract No.  
County

C204455

Chatham, Moore

Rev 5-17-11

CONTRACT PAYMENT BOND

*Affix Seal of Surety Company*



**Western Surety Company**

Print or type Surety Company Name

By **Terry D. Reynolds, Attorney-in-Fact**

Print, stamp or type name of Attorney-in-Fact

A handwritten signature in blue ink that reads "Terry D. Reynolds".

Signature of Attorney-in-Fact

A handwritten signature in blue ink that reads "Kendra A. Reynolds".

Signature of Witness

**Kendra A. Reynolds, Surety Witness**

Print or type Signer's name

10320 Little Patuxent Parkway, Suite 560, Columbia, MD 21044

Address of Attorney-in-Fact

**CONTRACT PAYMENT BOND**

**CORPORATION**

SIGNATURE OF CONTRACTOR (Principal)

Freyssinet Inc.

Full name of Corporation

44880 Falcon Place, Suite 100, Sterling, VA 20166

Address as prequalified

By Michael Louis  
Signature of President Vice President, Assistant Vice President  
*Select appropriate title*

Michael Louis  
Print or type Signer's name

*Affix Corporate Seal*



Attest [Signature]  
Signature of Secretary Assistant Secretary  
*Select appropriate title*

Raphael Martion  
Print or type Signer's name

Contract No.  
County

**C204455**

Chatham, Moore

Rev 5-17-11

**CONTRACT PERFORMANCE BOND**

Date of Performance Bond Execution: July 3, 2024

Name of Principal Contractor: Freyssinet Inc.

Name of Surety: Western Surety Company/Bond No. 30217046

Name of Contracting Body: North Carolina Department of Transportation  
Raleigh, North Carolina

Amount of Bond: \$6,392,193.80

Contract ID No.: C204455

County Name: Chatham, Moore

KNOW ALL MEN BY THESE PRESENTS, That we, the PRINCIPAL CONTRACTOR (hereafter, PRINCIPAL) and SURETY above named, are held and firmly bound unto the above named Contracting Body, hereinafter called the Contracting Body, in the penal sum of the amount stated above for the payment of which sum well and truly to be made, we bind ourselves, our heirs, executors, administrators, and successors, jointly and severally, firmly by these presents.

THE CONDITION OF THIS OBLIGATION IS SUCH, that whereas the principal entered into a certain contract with the Contracting Body, numbered as shown above and hereto attached:

NOW THEREFORE, if the principal shall well and truly perform and fulfill all the undertakings, covenants, terms, conditions, and agreements of said contract during the original term of said contract and any extensions thereof that may be granted by the Contracting Body, with or without notice to the Surety, and during the life of any guaranty required under the contract, and shall also well and truly perform and fulfill all the undertakings, covenants, terms, conditions, and agreements of any and all duly authorized modifications of said contract that may hereafter be made, notice of which modifications to the surety being hereby waived, then this obligation to be void; otherwise to remain in full force and virtue.

IN WITNESS WHEREOF, the above-bound parties have executed this instrument under their several seals on the date indicated above, the name and corporate seal of each corporate party being hereto affixed and these presents duly signed by its undersigned representative, pursuant to authority of its governing body.

Contract No.  
County

**C204455**

Chatham, Moore

Rev 5-17-11

**CONTRACT PERFORMANCE BOND**

*Affix Seal of Surety Company*

**Western Surety Company**

Print or type Surety Company Name



By **Terry D. Reynolds, Attorney-in-Fact**

Print, stamp or type name of Attorney-in-Fact

  
Signature of Attorney-in-Fact

  
Signature of Witness

**Kendra A. Reynolds, Surety Witness**

Print or type Signer's name

10320 Little Patuxent Parkway, Suite 560, Columbia, MD 21044

Address of Attorney-in-Fact

**CONTRACT PERFORMANCE BOND**

**CORPORATION**

SIGNATURE OF CONTRACTOR (Principal)

Freyssinet Inc.

Full name of Corporation

44880 Falcon Place, Suite 100, Sterling, VA 20166

Address as prequalified

By Michael Louis

Signature of President, Vice President, Assistant Vice President  
Select appropriate title

Michael Louis

Print or type Signer's name

Affix Corporate Seal



Attest

[Signature]  
Signature of Secretary, Assistant Secretary  
Select appropriate title

Raphael Manton

Print or type Signer's name



# Western Surety Company

## POWER OF ATTORNEY APPOINTING INDIVIDUAL ATTORNEY-IN-FACT

Know All Men By These Presents, That WESTERN SURETY COMPANY, a South Dakota corporation, is a duly organized and existing corporation having its principal office in the City of Sioux Falls, and State of South Dakota, and that it does by virtue of the signature and seal herein affixed hereby make, constitute and appoint

**Terry D Reynolds, Karen C Bowling, Diana L Parker, Michele Alban, David Saul, Individually**

of Columbia, MD, its true and lawful Attorney(s)-in-Fact with full power and authority hereby conferred to sign, seal and execute for and on its behalf bonds, undertakings and other obligatory instruments of similar nature

**- In Unlimited Amounts -**

and to bind it thereby as fully and to the same extent as if such instruments were signed by a duly authorized officer of the corporation and all the acts of said Attorney, pursuant to the authority hereby given, are hereby ratified and confirmed.

This Power of Attorney is made and executed pursuant to and by authority of the Authorizing By-Laws and Resolutions printed at the bottom of this page, duly adopted, as indicated, by the shareholders of the corporation.

In Witness Whereof, WESTERN SURETY COMPANY has caused these presents to be signed by its Vice President and its corporate seal to be hereto affixed on this 5th day of February, 2024.



WESTERN SURETY COMPANY

*Larry Kasten*

Larry Kasten, Vice President

State of South Dakota }  
County of Minnehaha } ss

On this 5th day of February, 2024, before me personally came Larry Kasten, to me known, who, being by me duly sworn, did depose and say: that he resides in the City of Sioux Falls, State of South Dakota; that he is a Vice President of WESTERN SURETY COMPANY described in and which executed the above instrument; that he knows the seal of said corporation; that the seal affixed to the said instrument is such corporate seal; that it was so affixed pursuant to authority given by the Board of Directors of said corporation and that he signed his name thereto pursuant to like authority, and acknowledges same to be the act and deed of said corporation.

My commission expires

March 2, 2026



*M. Bent*

M. Bent, Notary Public

### CERTIFICATE

I, Paula Kolsrud, Assistant Secretary of WESTERN SURETY COMPANY do hereby certify that the Power of Attorney hereinabove set forth is still in force, and further certify that the By-Law and Resolutions of the corporation printed below this certificate are still in force. In testimony whereof I have hereunto subscribed my name and affixed the seal of the said corporation this 3rd day of July, 2024



WESTERN SURETY COMPANY

*Paula Kolsrud*

Paula Kolsrud, Assistant Secretary

### Authorizing By-Laws and Resolutions

#### ADOPTED BY THE SHAREHOLDERS OF WESTERN SURETY COMPANY

This Power of Attorney is made and executed pursuant to and by authority of the following By-Law duly adopted by the shareholders of the Company.

Section 7. All bonds, policies, undertakings, Powers of Attorney, or other obligations of the corporation shall be executed in the corporate name of the Company by the President, Secretary, and Assistant Secretary, Treasurer, or any Vice President, or by such other officers as the Board of Directors may authorize. The President, any Vice President, Secretary, any Assistant Secretary, or the Treasurer may appoint Attorneys in Fact or agents who shall have authority to issue bonds, policies, or undertakings in the name of the Company. The corporate seal is not necessary for the validity of any bonds, policies, undertakings, Powers of Attorney or other obligations of the corporation. The signature of any such officer and the corporate seal may be printed by facsimile.

This Power of Attorney is signed by Larry Kasten, Vice President, who has been authorized pursuant to the above Bylaw to execute power of attorneys on behalf of Western Surety Company.

This Power of Attorney may be signed by digital signature and sealed by a digital or otherwise electronic-formatted corporate seal under and by the authority of the following Resolution adopted by the Board of Directors of the Company by unanimous written consent dated the 27th day of April, 2022:

“RESOLVED: That it is in the best interest of the Company to periodically ratify and confirm any corporate documents signed by digital signatures and to ratify and confirm the use of a digital or otherwise electronic-formatted corporate seal, each to be considered the act and deed of the Company.”

Go to [www.cnasurety.com](http://www.cnasurety.com) > Owner / Oblige Services > Validate Bond Coverage, if you want to verify bond authenticity.